アフリカにおける数学カリキュラムの内発的開発と制度化に
関する国際共同研究

研究期間 : 2021 年 10 月 - 2026 年 3 月

研究成果報告書

令和 8 (2026) 年 3 月

研究代表者 馬場 卓也

(広島大学 大学院人間社会科学研究科 教授)

目次

第1章	プロジェクト概要.....	1
1.1	極度の低学力問題とその問題へのアプローチ.....	2
1.2	フェーズIのレビュー.....	3
1.3	フェーズII調査の目的と方法.....	5
1.4	調査チームの構成と運営.....	6
第2章	調査の過程.....	9
2.1	準備の段階.....	10
2.1.1	概要.....	10
2.1.2	開発したツールの洗練.....	11
2.1.3	インタビューガイドの構成.....	13
2.2	最終段階：ツールと調査の実際.....	15
2.2.1	評価ツール・介入ツール間の対応関係.....	15
2.2.2	最終ツール（テスト）の構成.....	20
2.2.3	テストの実施方法.....	21
2.2.4	ワークショップの実施.....	22
2.2.5	事前事後調査.....	23
2.2.6	研究対象者とインタビューでのタスクの関係.....	24
2.2.7	教育的介入.....	24
第3章	分析結果.....	28
3.1	データ処理の方法.....	29
3.1.1	インタビューデータ.....	29
3.1.2	テストデータ.....	29
3.2	インタビューの分析結果.....	29
3.2.1	各学校における得点の変化・成績上位群と中位群による得点の変化.....	29
3.2.2	各学年におけるインタビュー得点の変化.....	30
3.2.3	各タスクにおけるインタビュー得点の変化.....	31

3.2.4 事前事後インタビューを受けた個々の児童の変化.....	34
3.3 テストの分析結果	37
第4章 考察.....	44
4.1 インタビュー分析に関する考察.....	45
4.2. テスト分析に関する考察	46
第5章 提言.....	47
5.1 政策に関する提言.....	48
5.2 研究に関する提言.....	49
参考文献.....	51
Annex.....	55
I-1 インタビューツール (Natural number, Decimal number)	56
I-2 インタビュー記録紙 (Grade 3&4, Grade 5&6)	85
II-1 テスト (For Grade 3 and 4, For Grade 5 and 6)	90
II-2 児童解答用紙 (Grade 3&4, Grade 5&6)	121
III-1 児童用ワークブック (Grade 3&4, Grade 5&6	134
III-2 教師用ガイド (Grade 3&4, Grade 5&6)	214

表

表 1	アジア・アフリカにおける学習貧困の実態	2
表 2	開発したツール	4
表 3	日本チーム	7
表 4	ザンビアチーム	7
表 5	インタビュー調査計画（調査校と対象児童数）	8
表 6	筆記テスト実施計画（調査校と対象児童数）	8
表 7	副コンピテンスとタスク	14
表 8	5つの反応レベルと具体例	15
表 9	インタビューガイド、テスト、ワークブック対応表	17
表 10	テスト問題の概要	20
表 11	事前調査実施日程 2024 年 3 月～4 月	23
表 12	事後調査実施日程 2024 年 6 月～7 月	23
表 13	調査タスクと学年の対応関係	24
表 14	教育的介入の実施日時	26
表 15	入力コードの一部	29
表 16	インタビュー対象者の情報	29
表 17	各学校における事前事後インタビューの得点	30
表 18	成績群における事前事後のインタビュー得点	30
表 19	各学年におけるインタビュー得点の平均値および差分の差分分析	31
表 20	各インタビュータスク項目の得点および差分の差分分析	32
表 21	第 3 学年における改善が最も大きかった児童 A（すべて自然数の問）	34
表 22	第 3 学年における改善が最も大きかった児童 B（すべて自然数の問）	34
表 23	第 4 学年における改善が最も大きかった児童 B（すべて自然数の問）	35
表 24	第 5 学年における改善が最も大きかった児童	36
表 25	第 6 学年における改善が最も大きかった児童 B	37
表 26	サンプルサイズ	38
表 27	第 3・4 年生のテスト問題	38
表 28	テスト得点の分布の記述統計量	39
表 29	第 5・6 学年のテスト問題	40
表 30	テスト得点の分布の記述統計量	41
表 31	差分の差分分析の結果	42
表 32	第 3・4 学年のロジスティック回帰分析の結果	42
表 33	第 5・6 学年のロジスティック回帰分析の結果	43

図

図 1	10 の枠	5
図 2	現地調査の様子	11
図 3	事前事後調査と介入ツールの対応	19
図 4	第 2 回ワークショップの様子：	22
図 5	事前調査の様子	24
図 6	事後調査の様子	24
図 7	小数タスク 1.2(1) における数直線	33
図 8	小数タスク 2.2 におけるタイル	33
図 9	整数タスク 1.3 における数直線	33
図 10	小数タスク 1.1 における数直線	34
図 11	小数タスク 1.4	34
図 12	第 3・4 年生における統制群と実験群のテスト得点の分布	39
図 13	第 5・6 年生における統制群と実験群のテスト得点の分布	41
図 14	統制群と実験群における事前事後のテスト得点の平均値の変化	42
図 15	乗法的考え方とその発展(Hurst &Hurrel, 2014)	45

はじめに

広島大学に就職したのが2001年、そしてザンビア特別教育プログラム(以下、ザンプロ)の学生を2名担当し、ザンプロに関わり始めたのが2003年である。それから20年以上の月日を重ねた。最初の学生は、もう50歳を超えた。当時、出会ったのが、これまで経験したことのない低学力問題であった。 $1/2+1/3$ という計算を、分子 $1+1$ 、分母 $2+3$ と分けて計算し、 $2/5$ とする答えは、日本でも見られる。しかしザンビアで見たのは、 $1+1+2+3$ というもので、もはや分数の影も形もなくなっている。

しばらくたち、ザンビアの理数科教育分野で、JICA技術協力プロジェクトが始まった。ザンプロ学生がプロジェクトと連携するようになり、広島大学の教員も順次、技術協力プロジェクトと連携するようになっていった。その中で、ザンビア人の理数科教育分野の研究者、技官や教員、教師の教師など、研修員や留学生として受け入れなどを行った。JICA技術協力プロジェクトでは、教員の力量形成に力点を置き、当時は教員に関わる課題に注目があつたと記憶している。

その後、ザンビア理数科教育での関わりに幾つかの転機があつた。一つは、カリキュラム、日本で言えば学習指導要領に関する動きである。もう一つは上記の低学力問題と関連が深い、子どもの学びに関する動きである。前者は、2013年にザンビア共和国がカリキュラム改定を行うということで、そのワークショップに招聘された。また後に、ザンビアでカリキュラム開発を担うカリキュラム開発局(CDC)の関係者の能力強化のため、広島大学でJICA国別研修を行った時期(2012-2015)があつた。そのようなかかわりを経て、2024年にJICAプロジェクト研究「アフリカ地域における初中等教育課程算数・数学及び理科カリキュラム比較分析」を行った際に、ザンビア教育省を訪問したが、その時に2014年に作成したカリキュラムの質は高いと評価をいただいた。

もう一つの低学力問題であるが、最初に判明し、内田豊海氏が博士論文「ザンビア基礎教育における計算能力の診断的評価に関する研究--弁別性と教授的示唆に注目して」(2009)を執筆して以降、体系的に取り組んでこなかった。その1つ目の理由は、低学力問題に取り組むには、小学校低学年で調査をする必要があり、それには現地語及び現地文化の理解が不可欠であることがあり、日本人研究者だけでは限界があることである。もう一つは、低学力問題に取り組むには、さまざまな状況があり、少数の個別の事例を集めても偶然の結果か全体的な傾向かわからないことである。国際教育調査(SACMEQ、PISA-D)や国家教育アセスメントなどから、非常に低学力であることはわかっている。したがって低学力の実情を知るためには、ある程度の数のデータを体系的に集め、傾向を調べる必要がある。

そのような中、JICAザンビア・プロジェクト研究「初等算数課題分析」2017年(平成29年)11月-2021年(平成33年)(コロナ感染症の拡大により1年間延長された)を受託した。ここでは、ザンプロに関して、長らく協働してきたザンビア大学の教員とその修士課程学生、そしてザンプロの修了生を中心に、アフリカ・ザンビアに知見を持っている数学教育分野で博士号を取得した修了生を集めた。したがって現地語、現地文化の理解はもちろんのこと、数学教育への理解も十分にあるチームを形成した。またJICA経由でザンビア教育省へ協力依頼を行い、ルサカ州ルサカ県の比較可能性の条件を持った10校の小学校に調査に

参加頂いた。

以上の成果を踏まえて、JICA プロジェクト研究報告書 ICA ザンビア・プロジェクト研究「初等算数課題分析」(2021)を作成した。成果を確認した一方で、残された課題として、対象とする数の範囲の拡大と、乗除算の意味の構成が判明した。

それを踏まえて、国際共同研究加速基金(国際共同研究強化(B))「アフリカにおける数学カリキュラムの内発的開発と制度化に関する国際共同研究」(2021-2026)を得て取り組んだのが、本研究であり、先に行った研究の継続研究となっている。上記と同様に低学力問題に取り組んだが、研究で取り上げた数学的な内容は、数の範囲を大きな数(1000までの数)と小数(小数第一位まで)に広げて、同時に、演算のなかでも乗除に力点を置いた。数学的内容を除き、実施体制(ザンビアチーム、日本チーム)は同じメンバーであり、また研究対象はザンビアルサカ州ルサカ県の10小学校である。

以上のように、本報告書は2003年に広島大学でザンビア教育開発に関わり始めてからの取り組みの総決算であり、今後の取り組みの礎となることを願って、まとめた。

2026年1月

馬場卓也

第1章 プロジェクト概要

1.1 極度の低学力問題とその問題へのアプローチ

1990年にタイ・ジョムティエンで開催された「万人のための教育世界会議」では、世界中が、学校に行けず教育の機会が奪われている子どもたちが多数存在することに、共通の課題意識を持った。その会議の成果として「万人のための教育世界宣言」を採択し、その課題に共同で取り組むことを表明した。その後、2000年には、セネガル・ダカールにて「万人のための教育」に関する「世界教育フォーラム」が開催され、国際社会は一体として初等教育の普及の重要性を再確認するとともに、目標の期限やモニタリングの重視などを謳った（小川他，2005）。2000年には、同時に開発問題全体をカバーするミレニアム開発目標（MDGs）も採択されて、初等教育の普及はその重要な目標の一つと位置づけられた。結果として、量的な改善が大幅に図られた。

このような最中、世界銀行は、新たな視角から教育問題を提起した。学校に行っていない通学損失（Schooling deprivation）と、学校に行っているが国が設定する最低限の学力が身につけていない学習損失（Learning deprivation）とを組み合わせ、「学習貧困」（Learning poverty）という考えから、学習貧困指数を提案した。そこでは、後者の学習損失がより深刻な状態にあること、共同で取り組んできた学校へ通学することは、問題の解決の一步に過ぎないことを指摘した。

表 1 アジア・アフリカにおける学習貧困の実態

	学習貧困	学習損失	通学損失
アジア			
Bangladesh	58.2	56.0	5.0
Cambodia	90.0	89.0	9.3
Indonesia	52.8	49.4	6.8
Thailand	23.4	21.9	1.9
アフリカ			
Ethiopia	90.4	88.7	14.8
Senegal	68.6	58.9	23.5
Uganda	81.9	81.1	4.4
Zambia	98.5	98.2	14.9

World Bank (2022)

表1では、学習貧困指数が示されているアジアとアフリカのいくつかの国での値を示している。それによれば、アジアと比較して、サブサハラアフリカ地域における問題はより深刻である。

このような学習貧困が極めて深刻な国においては、社会文化的な影響（国内機関・専門家の脆弱性、教育言語の学習への影響、教師の力量不足、教材の未整備・不足、教育課題への優先順位への影響）がある。先進国で開発されたアプローチでは、そのような社会文化的な影響を十分に考慮した上での改善は難しいと考えられる。そこで、本研究では、専門性、教

授言語、教師の力量、教材などを念頭に置き、ザンビアの子どもたちにあった解決法を探究的に求めるエビデンスに基づく内発的アプローチ (Baba & Nkhata, in press) の立場をとった。つまり、開発途上国が自ら数学教育課題の本質を捉え、データを基に考察・改善を探ることを目指したものである (馬場、2025)。

1.2 フェーズ I のレビュー

本節は、JICA & Hiroshima University (2021) と Baba et al. (2019) に基づいて記述する。ザンビアにおいては 2000 年以降、教育省の努力により教育の量 (就学率) は大幅に改善されている。事実上記の表 1 においても、通学損失は 14.9 であり、そのことは裏を返せば、純就学率は 85.1% である。ところが学習損失は 98.2% であり、通学しているザンビア児童の内、98.2% の児童は政府が設定するミニマムなレベルに達していないことを示している。加えて、数学教育の質に関して、国や地域、国際的な教育評価である National Assessment Survey (NAS) (MoGE, 2017)、The Southern and Eastern Africa Consortium for Monitoring Educational Quality (SACMEQ) (Hungu et al., 2010; Moris, 2021), PISA (OECD, 2019) などは、非常に深刻な問題を指摘している。そして、先行研究 (Nakawa, 2016; Uchida, 2009) は、児童は計算において、数え上げの方略が支配的であることを明らかにしている。

このような現状を踏まえて、本プロジェクトフェーズ I (2017-2021) では、以下のとおり現地調査を実施し、ザンビア児童の基礎的算数能力を診断する評価ツール、および算数能力を改善するための介入ツールを開発した。

[調査の概要]

調査目的：ザンビア児童の基礎的算数能力に関する評価ツールと介入ツールを開発し、その改善を行うこと

調査期間：2017 年から 2021 年 (準備段階：2018-2020、最終段階：2021)

調査方法：インタビュー調査および筆記テスト

対象地域：ザンビア ルサカ州ルサカ市

対象校：研究上の便宜により、ルサカ州ルサカ市を選択したうえで、その中にある 5 地区 (Zone) から社会経済的な観点から類似している学校を教育省より 2 校ずつ推薦してもらった。以下、そのリストである。

- Chipata Primary School
- New Kabanana Primary School
- Muchinga Primary School
- George Central Primary School
- Chamba Valley Primary School
- Kaunda Square Primary School
- Twashuka Primary School
- John Laing Primary School
- New Kamulanga Primary School
- Chimwemwe Primary School

対象学年：1年生から4年生

基礎的算数能力の定義；

以下に関する理解。

- ・ 100までの自然数
- ・ 十進法
- ・ 四則演算（たし算、ひき算、かけ算、わり算）

加えて、

- ・ 問題を読み、数学的に表現する力

[調査のプロセス]

ザンビア児童の能力を適切に評価するためには、児童の実態に対してテスト問題が妥当であること（児童の実態に対する妥当性）、またテスト問題が数学能力の成長の観点から見て妥当であること（数学能力に対する妥当性）が求められる。したがって、デザイン実験（Gravemeijer & Cobb, 2006）の手法を用いて、最初に開発した診断的評価問題案を実施、修正を繰り返し、妥当性を高める方法を取った。実際には、表3のように2018年3月、9月、2019年3月、9月と4回にわたり予備調査を実施した。

繰り返しの内実は次のとおりである。文献及びカリキュラムに基づき最初の案を作成し、準備段階で予備調査を行い、児童の反応を確認しながら、問題の全体量、問題文の表現、タスクの妥当性、評価ループリックの表現などを確認し、評価ツール（テスト問題及び評価ループリック）を洗練した。問題は、一斉に実施するのではなく、1名に対して一問ずつインタビューする方式で行った。そうすることで子どもの思考実態を捉えることができるからである。

そしてインタビューの判断が安定するようになってから、対象人数を増やすために、一斉に実施する評価ツール（筆記テスト問題）も開発した。また、最終段階で2020年3月に本調査を予定していたが、新型コロナウイルスの感染拡大により実施できず、1年をかけて日本チームがオンラインで参加する代替的な方法を開発した。ハイブリッド形式で2021年3月に事前調査、6月に事後調査を実施した。

なお、実験群5校には事前、事後調査の間に介入ツールを用いた介入活動を行うことで、統制群との比較から介入の有効性を検証した。なお、介入ツールは、評価ツールと項目ごとに対応しており、評価ツールによって明らかにされた児童の課題を乗り越えられるように作成した問題集及び教授上のヒントを含むものである。

表2 開発したツール

評価ツール	インタビュー問題、評価ループリック
	筆記テスト
介入ツール	児童用問題集
	教師用指導書

[調査結果と残された課題]

評価ツール（インタビュー問題）を用いたインタビュー調査で明らかになったのは主に二点であった。一点目は、実験群の児童は具体物を1ずつ数える段階からまとまりで数把握する段階に変容したことである。二点目は、実験群では全員の結果が向上し、解答時間の短縮が見られたことである。これは統制群の児童と比較して差が大きかった。

また、もう一つの評価ツール（筆記テスト）で明らかになったことは主に二点であった。一点目は、数をまとまりで見ているかに関する問題と数を数える問題において、実験群と統制群に統計的に有意な差が見られたことである。二点目は、計算問題においては実験群と統制群で統計的な有意差が確認できなかったことである。これは、全ての問題が二桁までの数で構成されており、数え上げで答えを出すことが可能であったという理由が考えられた。

他方で残された課題は、次の二点である。一点目は、乗除算である。全体として実験群においては明確な効果が見られたものの、乗除算に関してはほとんど効果が見られなかった。まとまりを捉えるための主要な介入ツールとして、10の枠(図1)を導入したが、乗除算は10の枠だけでは解決できないことが分かった。

図1 10の枠

二点目は、数のまとまりを捉えた上で、位間の関係を理解することである。つまり、10の枠を導入したことにより、個々で見えていたものを、10のまとまりを捉えることはできるようになった。これは、“数を構造的に捉えること”を目指す第一歩である。しかし10の枠が固定した見方になっては、新たな「数え上げ」になってしまう。10のまとまりが10まとまったもの(100)、さらにそれが10まとまったもの(1000)のように、1、10、100、1000のまとまり(位)という数の構造を捉える必要がある。

1.3 フェーズII調査の目的と方法

ザンビアでは一般的に算数能力を評価するテストはNational Assessment Surveyのみで、また近隣諸国で行われる算数能力を評価するテストはThe Southern and Eastern Africa Consortium for Monitoring Educational Quality (SACMEQ)のみである。それらの調査結果は、上述のようにザンビア児童の極度に低い学力結果を示している。しかし、ザンビア児童の極度の学習貧困の中に隠されている潜在的な能力を知り改善に生かすためには、診断的に評価することが求められる(Uchida, 2009)。そこで、フェーズIと同様に、診断的な評価を行うインタビュー法を用いた。

前述したように、フェーズIで残された課題として、乗除算と位の関係が課題であった。そこでフェーズIIでは、乗法、除法に関して、特に乗法的考え方(Simon, 1995; Vergnaud, 1983, 2009)に力点を置き、計算の意味理解を明らかにすることとした。もう一つの課題、位の関係に関して、0.1, 1, 10, 100の位とその関係に力点を置き、数の構造的な理解、表現や

計算の意味理解を明らかにすることとした。乗除算および小数が主たる算数概念となるため、調査対象をザンビア児童3年生から6年生と設定した。

調査方法はフェーズ I と同様、デザイン実験(Gravemeijer & Cobb, 2006)の手法を用いて、開発段階での予備調査を3回行う中で評価ツールと介入ツールを開発した。研究対象校は前述したフェーズ I と同じ学校10校である。最終段階の事前調査と事後調査ではこれらの10校を対象に評価ツール(インタビュー問題及び筆記テスト)を用いた調査を行った。うち実験校5校にて事前、事後調査の間に介入ツール(問題集及び教授上のヒント)を用いた介入活動を行うことで、事後調査において統制群との成績に差が出るのか、またそのツールの有効性について検証した。

調査目的：ザンビア児童の基礎的算数能力に関する評価ツールと介入ツールを開発し、その改善を行うこと

調査期間：2022年から2025年

調査方法：同上

対象地域：同上

対象校：同上

対象学年：3年生から6年生

基礎的算数能力(コンピテンス)の定義：

- ・0.1, 1, 10, 100の位と自然数および小数
- ・上記の位の間関係
- ・四則演算(特に、かけ算、わり算)
- ・数学的に表現する力

1.4 調査チームの構成と運営

本調査においては、学習貧困が極めて深刻な国において、エビデンスに基づく内発的アプローチ(Baba & Nkhata, in press)の立場を取るため、現地の社会文化的な背景や算数・数学教育の現状・課題が分かることが重要である。つまり、馬場を含む日本チーム5名(表3)は、ザンビア特別教育プログラム¹の参加者や国際協力実践に関わったことのあるもので、ザンビアの教育、国際協力に関して深い知見を持ち、全員が数学教育の博士号を取得している。また2名の大学院生も参加し、本研究プロジェクトの実施に多大な貢献をしつつ、彼ら自身の研究も近接分野で行い、プロジェクトに貴重な知見をもたらした。

ザンビアチームについて、リーダーのNkhataを除く6名(表4)はプロジェクトのフェーズ I 実施期間中にザンビア大学修士課程の在学者および修了者から選抜されたものである。彼らは数学教育において十分な能力とやる気を備えており、プロジェクトで開発する評価ツールのアプローチと意義を深いレベルで理解し、ザンビアの児童の実態を理解してい

¹ 広島大学が2002年より、JICA 海外協力隊事務局と共同実施する、国際協力人材育成のための教育プログラムである。修士課程の学生を2年間、ザンビアに海外協力隊員として派遣し、そこでの経験を修士論文に活用する。

る。彼らが修士課程終了後も、教育省や配属先の理解を得てプロジェクトに継続的に関わってくれたことは、本研究を遂行する上で必要不可欠な条件であった。

また、日本側とザンビア側にそれぞれ 1 名を業務調整役として配置し、チーム内でのコミュニケーション、教育省や調査対象校などとの連絡調整、渡航の際の車やホテルの手配などを行った。フェーズ II では最終段階の事前、事後調査時に 2 名の臨時アシスタントを動員したものの、主要メンバーについてはフェーズ I からの変更はなく、運営体制としては万全の体制で調査を実施することができたと考える。

表 3 日本チーム

氏名	所属先	担当
馬場 卓也	広島大学	総括/チームリーダー 業務調整 報告書作成
中和 渚	関東学院大学	
日下 智志	鳴門教育大学	
渡邊 耕二	宮崎国際大学	
高阪 将人	福井大学	
皆越 香苗	広島大学	
古川 奈津子	広島大学	
安部喜敬	広島大学院生	
湯田しおり	福島県（当時院生）	

表 4 ザンビアチーム

氏名	所属先	担当
Nkhata Bentry	ザンビア大学	チームリーダー 業務調整
Arthur Mungalo	チャールズ・ルワンガ教員養成校	
Mudenda Barbara	ヨロ中等学校	
Kaabo Emmanuel	デビット・リビングストーン教員養成校	
Mambwe Bareford	ムカンド中等学校	
Chikola Doye	セントメリー教員養成校	
Tafeni Spiwe	ムクシ・デイ中等学校	
Takuzwa Jane Njovu		

1.5 研究対象校と研究対象者

ザンビア教育省からの許可、協力を得て、フェーズ I において調査対象校であったルサカ州ルサカ群の 10 校の公立初等学校にて、継続的に調査を実施した。また、フェーズ II では教育省からチームとの調整役 (Ms. Shelly Sikwale) が任命された。調査対象校は、ルサカ州ルサカ群の 5 地域 (Zone) から 2 校ずつが選定されており、その 2 校は社会経済的な状況が類似していると考えられ、実験群と統制群の条件の類似性を担保できた。また実験群と統制群の振り分けについてはフェーズ I と同様とした。

各学校において、3年生から6年生の各学年から2名ずつをインタビュー対象者とした。1名は成績上位者、もう1名は成績中位者であり、その選定はクラス担当教員に依頼した。(表5) また筆記テストは、各校、各学年からインタビュー対象者を含む20名を対象とし、3、4年生(計40名)を合同で、5、6年生(計40名)を合同で実施した。(表6)

表5 インタビュー調査計画(調査校と対象児童数)

	開発段階			最終段階		
	2022	2023		2024		
	9月 第1回	3月 第2回	9月 第3回	3月 事前調査	6月 事後調査	
学校数	5	5	5	10	10	
児童数	3年生	10	10	10	20	20
	4年生	10	10	10	20	20
	5年生	10	10	10	20	20
	6年生	10	10	10	20	20

表6 筆記テスト実施計画(調査校と対象児童数)

	最終段階		
	2024		
	3月 事前調査	6月 事後調査	
学校数	10	10	
児童数	3年生	100	100
	4年生	100	100
	5年生	100	100
	6年生	100	100

第2章 調査の過程

2.1 準備の段階

2.1.1 概要

フェーズ II では、フェーズ I と同様の手順で 3 回の予備調査を実施した。各回において、問題解決におけるインタビュー法を用いて、児童による問題解決の状況および数学的な考えを日本人、ザンビア人を含む複数のメンバーで観察し、その解釈・評価について議論を重ねた。単独の観察ではなく、複数の視点（複数人と日本人、ザンビア人の視点）を取り入れることで、多角的に見ることが可能となり、より客観的で妥当な評価につながる。特に、観察の過程で得られるデータの解釈には主観的な要素が含まれるため、チームでの議論を通じてその解釈の妥当性を確認した。またタスク間の一貫性を確保することを重視した。

インタビューの様子はすべて録画し、観察者がその場で得た印象や記録と照らし合わせながら議論を行った。録画データは、特定の児童の反応を詳細に分析する際や、チーム内で意見が分かれた場合に、解釈を再点検するために活用した。これにより、一度だけ、一人だけの解釈に依存せず、より客観的な視点から、信頼性のある評価を行うことができた。

客観性：複数（複数名、多文化、複数回）の視点の観察・解釈の一致

妥当性：カリキュラムや先行研究を踏まえて作成されたタスクの意図とインタビューで得られたデータの対応状況

信頼性：実施者、タイミングを変えても、測定結果が一定している

一貫性：前後のタスク間での解釈の一致

タスクと反応レベル

問題解決におけるインタビュー法において、使用するタスクは重要である。児童の基礎的な算数能力（コンピテンス）をより細かい要素に分解した問題（タスク）を開発した。それを用いたインタビューは個別に実施され、インタビューの観察者は、児童が各タスクに対してどのような反応を示すかを評価した。ここでは、5 段階レベルをもちいて児童の反応を評価した（詳細は 2.2「開発したツールの洗練」および 2.3「インタビューガイドの構成」に記載）。その際に、レベルの判断基準が重要であるが、最初の予備調査では判断基準と子どもの実態が必ずしも一致せず、観察者によって判断が分かれた。また異なるタスク間で、判断基準が異なった。議論を通して、より明確にレベルの区別が付き、観察者による差がなくなり、タスク間に共通して、使える基準となっていた。

以下の手順に従い、調査を実施した。

[手順 1]

先行研究および先行調査を分析し、調査の内容的妥当性を高めるよう努めた。

[手順 2]

タスクや反応レベルを含む評価ツールを、開発あるいはデータを基に改訂した。3 回の予備調査において、判断基準に基づいてレベルを判断する中で、レベルや判断基準について議論を行った。回答時間や測定エラーの影響についても検討した。

[手順 3]

タスクの数を減らすことで、適切な範囲の回答時間（目安：30～40分／人）に調整し、測定エラーの発生を抑えるようにした。さらに、判断基準があいまいで、判断にぶれが生じる場合は基準を修正した。

なおインタビューは、インタビュアー、観察者、カメラマン、日本人のメンバーで実施した。日本人は、日本から Zoom を通して参加するときもあった。



図2 現地調査の様子

現地の参加者の数は最低限確保したうえで、カメラマンは同時に「観察者2」としての役割も担った。日本人を含む複数のメンバーで観察・議論を行うことで、観察の客観性と一貫性を高めた。

2.1.2 開発したツールの洗練

本研究で開発した評価ツールは、児童の基礎的な算数能力（コンピテンス）をより細かい要素に分解し、それぞれの「副コンピテンス」に対応する問題（タスク）を実施する形で構成された。それによって、児童の算数能力の特徴を詳細に把握し、各能力を段階的に評価することが可能となった。単に正誤を判定するのではなく、児童の思考過程や誤答の背景を精査することで、理解や学習のつまずきをより精密に分析することを目指した。

また、本研究では、評価ツール（インタビューガイド、テスト）の妥当性（内容的妥当性）と信頼性を向上させるために、現場での試行と改善を繰り返した。その結果、以下の3つの主要な側面－構成、インタビュー方法、反応レベル－において、評価ツールの洗練が進められた。

基礎的算数能力（コンピテンス）の定義（再掲）；

- ・ 0.1, 1, 10, 100 の位と自然数および小数
- ・ 上記の位の間関係
- ・ 四則演算（たし算、ひき算、かけ算、わり算）
- ・ 問題を読み、数学的に表現する力

A) タスクの内容と構成の精緻化

各副コンピテンスの測定に適した問題（タスク）を選定(表7)し、児童の算数能力を引

き出すための工夫を加えた。特に、以下のような算数の基本概念に関するタスクを取り入れた。

- 数の位取りに関する問題
児童が数の構造をどの程度理解しているかを評価するため、位間の関係（100、10、1、0.1 という位）や数の大小を比較する課題を出題した。
- タイルやグリッドを用いた表現の問題
様々な図的表現を活用した問題を取り入れ、数の大きさや関係を視覚的に捉える力を評価した。一つのグリッドの単位を変えて数を捉えさせたり、タイルを使って計算を表現させたりして、児童の概念理解の深さを測定した。ここでは、数が100以上になったり、0.1のように小数になったりするため、「もし…ならば」（例：一つの大きな箱が100ならば）という仮定的な表現も取り入れた。
- 数直線を用いた問題
数の大きさや関係性を理解するための手段として、様々な表現は数の連続性を表現するには、最終的に数直線に集約されるため、数直線もタスクに取り入れた。児童に数直線上での位置を示させたり、数直線上で数値を比較させたりする課題を設定した。目盛りと目盛りの間にも数が存在していることを理解させるために、目盛りのつけ方を替えたりした。

これらのタスクを通じて、児童が数の概念をどのように捉え、操作しているのかを詳細に分析できるようにした。

B) 現地語でのインタビュー方法の洗練

インタビューの方法を統一し、タスク間の一貫性を高めるために、質問の仕方や表現の統一を図った。具体的には、以下の改善を実施した。

- 質問内容の標準化
インタビュアーが問題を読み上げるが、インタビュアーごとの言い回しの違いによる影響を最小限にするため、使用するキーワードや質問の文言を統一し、詳細なインタビューガイドを作成した。特に質問自身がヒントにならないこと、質問が児童を間違った方向に誘導しないことなどを確認した。ガイドにより、質問の内容や問題の意図が統一され、データの一貫性が保たれるようになった。
- インタビュアー間の訓練の強化
インタビュアーごとの解釈の違いによる尋ね方のブレを防ぐため、事前にロールプレイを行い、実際の進め方を確認した。また、児童の反応に対する適切な追加質問についても議論し、評価の信頼性を向上させるよう努めた。
- 現地語の表現の精査
児童が理解しやすい言葉で質問を行うため、現地語における適切な表現を検討し、質問の言い回しを調整した。特に、数直線やグリッドの説明に関しては、数学的な概念を直感的に伝えるための表現を現地語で適用し、児童が質問の意図を正しく理解できるようにした。

C) 反応レベルの判断基準の精密化

児童の回答をより正確に評価するため、反応レベルを判断する際の基準をより明確にした。特に、児童がどのように思考し、どのように誤りに気付くのかを、評価できるようにした。

- 誤りへの気付きと自己修正の考慮
児童が問題の解き方を説明する際や、インタビュアーからの聞き返しや追加質問を受けた際に、自ら誤りに気付くケースが多いことが確認された。これを踏まえ、誤りに気付いた過程を評価に反映することを明確にした。例えば、児童が最初に誤った解答を示したものの、説明を進める中で自己修正した場合、その修正のプロセスを考慮した評価ができるようにした。
- 理由の説明に関する基準の設定
児童が自身の解答に関する説明を行う際、その理由含めて評価するため、レベル4およびレベル5の判断基準を明確化した。これにより、児童の算数的理解がどの程度深いのかについてより適切に判断できるようになった。
- 反応レベルの細分化と客観的な指標の導入
児童の思考過程を評価するため、単なる正誤ではなく段階ごとに適切な指標を設けることとした。例えば、数直線の問題においては、児童が単に数の位置を示すだけでなく、その数がどのように数直線上の他の数と関係するのかを説明できるかどうかを評価基準とした。

2.1.3 インタビューガイドの構成

3回の現地調査を経て、測定エラーはほとんど解消された。観察者が観察時に異なる判断をした場合でも、最終的な判断を確定する際には、判断基準に立ち戻って議論を行うことで合意に至ることができた。このようにしてインタビューガイドは最終化された。

表 7 副コンピテンスとタスク

副コンピテンス (Sub-competence)	タスク (Task)	
	Natural number	Decimal number
I. Number Representation	1.1 Counting	1.1 Understand the structure of a number line (a hierarchy of 100's and 10's unit) and read the numbers struck on the number line for a given number
	1.2 Understand the structure of a number line (a hierarchy of 100's and 10's unit) and type the given number on the number line	1.2 Counting
	1.3 Understand the structure of a number line (a hierarchy of 100's and 10's unit) and read the numbers struck on the number line for a given number	1.3 Understand the structure of a number line (a hierarchy of 100's and 10's unit) and type the given number on the number line
	1.4(1) Assuming that the grid (with line) represents 100, answer the enclosed numbers	1.4(1) Assuming that the grid (with line) represents 1, answer the enclosed numbers
	1.4(2) Grid to number lines	1.4(2) Grid to number lines
	1.5(1) Assuming that the grid (without line) represents 100, enclose number	1.5(1) Assuming that the grid (without line) represents 1, enclose number
	1.5(2) Assuming that the grid (with line) represents 100, enclose a specific number	1.5(2) Assuming that the grid (with line) represents 1, enclose a specific number
II. Comparison numbers	2.1 Comparison using number	2.1 Comparison using number
	2.2 Representing numbers and compare numbers represented by tiles	2.2 Representing numbers and compare numbers represented by tiles
	2.3 Judging by number lines/ Representing numbers and comparing numbers represented by a number line	2.3 Judging by number lines/ Representing numbers and comparing numbers represented by a number line
III. Calculation	3a Addition	3a Addition
	3s Subtraction	3s Subtraction
	3m (1) Multiplication	3m (1) Multiplication
	3m (2)(3) Representing multiplication using tiles	3m (2)(3) Representing multiplication using tiles
	3d (1) Division	3d (1) Division
	3d (2)(3) Representing division using tiles	3d (2)(3) Representing division using tiles

最終のインタビューガイドでは、タスクの基礎性と発展性を考慮して、3つの副コンピテンスで構成された（表5）。また各タスクにおいては、児童の反応を診断的に、一貫性をもって判断できるように、タスク間で5つの反応レベルの基準を統一した。ここで「診断的」は二つのこと（① 児童の理解のレベルを同定する、② 児童の理解を深めるための介入ポイントを示唆する）を意味する。例えば、レベル4と判断された児童は問われた問題には正答しているが、なぜその答えが導けるのかタイルや数直線などを用いて説明をすることができない。したがって、レベル5（具体物を用いて説明すること）を意識するような介入が行える、ということを示している（表8）。一貫性は、判断基準のタスク間での関係性を示している。

表8 5つの反応レベルと具体例

反応レベル	レベルの描写		注釈
Level 1	Cannot say the answer.	Neither of them is correct	
Level 2	The represented numbers are incorrect	Only former (1) or latter (2) is correct	
Level 3	The represented numbers are correct. (A pupil/ interviewer asks some questions.)	Both former and latter are correct. (A pupil/ interviewer asks some questions.)	児童が問題の解き方を説明しているときや、インタビュアーが聞き返したり質問したりする中で誤りに気付いた場合
Level 4	The represented numbers are correct smoothly	Both former and latter are correct smoothly	
Level 5	The represented numbers are correct smoothly with explanation	Both former and latter are correct smoothly with explanation	

2.2 最終段階：ツールと調査の実際

2.2.1 評価ツール・介入ツール間の対応関係

先に述べたように、本研究では、ザンビア児童の極度の学習貧困の中に隠されている潜在的な能力を診断的に評価する（Uchida, 2009）ために、タスクを用いたインタビュー法を用いた。つまり、本研究では、インタビューを用いた診断的評価の開発が核となっている。それを踏まえて、最終的な成果を介入活動と事前・事後評価によって確認するために、評価ツール（インタビューガイド、テスト）、介入ツール（児童用ワークブック、教師用ガイド）を開発した。事前、事後調査に用いる評価ツール（テスト）、介入ツールはインタビューガイドに対応付けて開発された（表9、図3）。

介入ツール（児童用ワークブック）は、インタビューガイドに基づいて作られたある種

の練習帳で、介入ツール（教師用ガイド）は児童用ワークブックの説明書である。児童用ワークブックには、本来のタスクに取り掛かる予備的なものとして、1、10、100のタイルでの表現の方法や数直線やグリッドの表現の方法、タイルを用いた計算の表現の方法などにつながる基礎的な問題（Extra Practice）を追加した。教師用ガイドでは副コンピテンス、各タスクの意図、指導上の留意点を説明し、教員が自ら学び、工夫できるようにした。介入時に数名の教員はワークブックを非常に効果的に使用している例が観察できた。

表 9 インタビューガイド、テスト、ワークブック対応表

Natural Number		タスク	テスト	ワークブック
I. Number Representation	Counting	1.1		
	Understanding the structure of a number line and read the numbers struck on the number line for a given number	1.3	Q1	(G3,4) Extra B Practice 3 (G4,5) Extra NB Practice N2
	Understanding the structure of a number and type the given number on the number line	1.2	Q2(G3,4) Q1(G5,6)	Practice 4
	Assuming that the grid (with line) represents 100, and reading a number	1.4(1)	Q3(G3,4) Q2(G5,6)	(G3,4) Extra A Practice 1 (G4,5) Extra NA Practice N1
	Assuming that the grid (with line/without line) represents 100, and enclosing a number	1.5	Q4	Practice 2
	Representing a number by tiles		Q5(G3,4) Q3(G5,6)	Extra C.D
	Understanding the structure of grids to number lines	1.4(2)	Q6	Practice 5
	II. Comparison numbers	Representing numbers and compare numbers represented by tiles	2.2	G3,4 Q7
Judging by number lines/ Representing numbers and comparing numbers represented by a number line		2.3	Q8	Extra G Practice 8
Comparison using number		2.1	Q9	Extra F Practice 7
III. Calculation	Addition	3a(1)	Q12(a)	Practice 9
	Representing addition using tiles	3a(2)(3)		Extra H
	Subtraction	3s(1)	Q12(b)	Practice 10
	Representing subtraction using tiles	3s(2)(3)		Extra I
	Multiplication	3m(1)	Q12(c)	Practice 13
	Representing multiplication using tiles	3m(2)(3)	Q10(2)	Extra J
	Representing addition formula and multiplication formula		Q10(1)	Practice 11
	Division	3d (1)	Q12(d)	Practice 14
	Representing division using tiles	3d (2)(3)	Q11(2)	Extra K
	Representing the division sentence for the diagram		Q11(1)	Practice 12
Word problem		Q13	Extra L	

Decimal number

		タスク	テスト	ワークブック
I. Number Representation	Counting	1.2		
	Understanding the structure of a number line and read the numbers struck on the number line for a given number	1.1	Q5	Extra B Practice 3
	Understanding the structure of a number and type the given number on the number line	1.3	Q4	Practice 4
	Assuming that the grid (with line) represents 1, and reading a number	1.4(1)	Q6	Extra A Practice 1
	Assuming that the grid (with line/ without line) represents 1, and enclosing a number	1.5	Q7	Practice 2
	Representing a number by tiles		Q8	Extra C.D
	Understanding the structure of grids to number lines	1.4(2)	Q9	Practice 5
II. Comparison numbers	Representing numbers and compare numbers represented by tiles	2.2	Q10	Extra E Practice 6
	Judging by number lines/ Representing numbers and comparing numbers represented by a number line	2.3	Q11	Extra G Practice 8
	Comparison using number	2.1	Q12	Extra F Practice 7
III. Calculation	Addition	3a	Q15(a)	Practice 9
	Representing addition using tiles	3a(2)(3)		Extra H'
	Subtraction	3s	Q15(b)	Practice 10
	Representing subtraction using tiles	3s(2)(3)		Extra I'
	Multiplication	3m(1)	Q15(c)	Practice 13
	Representing multiplication using tiles	3m(2)(3)	Q13(2)	Extra J'
	Representing addition formula and multiplication formula		Q13(1)	Practice 11
	Division	3d (1)	Q15(d)	Practice 14
	Representing division using tiles	3d (2)(3)	Q14(2)	Extra K'
Representing the division sentence for the diagram		Q14(1)	Practice 12	
Word problem		Q16	Extra K'	

図 3 事前事後調査と介入ツールの対応

事前、事後調査におけるインタビューガイド抜粋

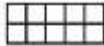
(1) If  represents 1, circle 2.6 using the grids/boxes. Explain the reason.

Local language: Ngati aka ka grid katantauza 1, sekoling'a 2.6 kusebenzesa tuma grid/box ita. Waziba bwangi?

(2) If  represents 1, circle 2.6 using the grids/boxes. Explain the reason.

Local language: Ngati aka ka grid katantauza 1, sekoling'a 2.6 kusebenzesa tuma grid/box ita. Waziba bwangi?

事前、事後調査におけるテスト抜粋

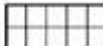
7. If the whole of this grid  represents 1, circle 2.6 using the grids/boxes.

Local language: Ngati aka ka grid kense katantauza 1, sekoling'a 2.6 kusebenzesa tuma grid/box.

教育的介入における児童用ワークブック抜粋

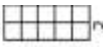
(1) If the whole of this grid  represents 1, circle 3.7 using the grids/boxes.

(Reason)

(2) If the whole of this grid  represents 1, circle 3.7 using the grids/boxes.

(Reason)

2.2.2 最終ツール（テスト）の構成

テスト問題の概要を表 10 に示す。整数の問題 1 から問題 6 および小数の問題 1 から問題 7 は、表現間の対応関係を明確にすることを通して、数の表現と十進構造の理解を確かめることを意図している。特に、数直線と数、グリッドと数、グリッドと数直線の 3 つの対応関係に関する問題を出題している。整数の問題 7 から問題 9 および小数の問題 10 から問題 12 は、数の大小比較に関する問題である。数における比較、タイルでの比較、数直線での比較に関する問題となっている。整数の問題 10 から問題 13 および小数の問題 13 から問題 16 は計算に関する問題である。式やタイルを使って四則計算の意味を問う問題、筆算、文章問題という構成となっている。

表 10 テスト問題の概要

整数

問題番号	概要	問題番号	概要
1	数直線に示された矢印が表す数を答える	10 (1)	$120+120+120+120=480$ を乗法の式に直す
2	数直線に 420 を表す矢印を記入する	10 (2)	1、10、100 のタイルを使って 3×210 を表す
3	10 個に区切られているグリッド全体を 100 としたとき囲まれた部分が表す数を答える	11 (1)	示されている図について除法の式で表す
4 (1)	10 個に区切られているグリッド全体を 100 としたとき 260 をまるで囲む	11 (2)	1、10、100 のタイルを使って $390 \div 3$ を表す
4 (2)	10 個に区切られていないグリッド全体を 100 としたとき 490 をまるで囲む	12a	$178 + 213$
5	1、10、100 のタイルを使って 234 を表す	12b	$286 - 147$
6	10 個に区切られているグリッド全体を 100 としたとき囲まれた部分が表す数を数直線上に示す	12c	230×3
7	1、10、100 のタイルで示された A と B のうち大きいものを答える	12d	$480 \div 4$
8	数直線に示された 2 つの矢印のうち大きいものを答える	13	$360 \div 3$ の文章題とその解き方
9 (1)	240 と 280 のうちどちらが大きいか答える		
9 (2)	350 と 620 のうちどちらが大きいか答える		

小数

問題番号	概要	問題番号	概要
1	数直線に 420 を表す矢印を記入する	13 (1)	$1.2+1.2+1.2+1.2=4.8$ を乗法の式に直す
2	10 個に区切られているグリッド全体を 100 としたとき 260 をまるで囲む	13 (2)	0.1、1、10 のタイルを使って 3×2.1 を表す
3	1、10、100 のタイルを使って 234 を表す	14 (1)	示されている図について除法の式で表す
4	数直線に 4.2 を表す矢印を記入する	14 (2)	0.1、1、10 のタイルを使って $390 \div 3$ を表す
5	数直線に示された矢印が表す数を答える	15a	$17.8 + 21.3$
6	10 個に区切られているグリッド全体を 1 としたとき囲まれた部分が表す数を答える	15b	$28.6 - 14.7$
7	10 個に区切られているグリッド全体を 100 としたとき 2.6 をまるで囲む	15c	2.3×3
8	0.1、1、10 のタイルを使って 23.4 を表す	15d	$4.8 \div 4$
9	10 個に区切られているグリッド全体を 1 としたとき囲まれた部分が表す数を数直線上に示す	16	$18.6 \div 3$ の文章題とその解き方
10	0.1、1、10 のタイルで示された A と B のうち大きいものを答える		
11	数直線に示された 2 つの矢印のうち大きいものを答える		
12 (1)	2.4 と 2.7 のうちどちらが大きいか答える		
12 (2)	1.8 と 3.4 のうちどちらが大きいか答える		

2.2.3 テストの実施方法

インタビュー対象者数が限られていたため、最終段階では介入効果を確認するために、より多くの児童に対するテストが実施された。方法として筆記試験を用いるが、検証したいことは、正誤のみならず、児童の計算過程や考え方を明らかにすることであった。例えば、用紙に示された半具体物（タイルなど）をまとまりで捉えたり、数えたりすることや、計算過程について記述させることで、その可能性を検討した。

ザンビアの低学年児童の多くが、英語による数学学習に困難性を有していること、1 年生から 4 年生までは現地語（調査地ルサカではニャンジャ語）で授業を受けていること、文章で示された現地語を読み解くことが児童にとって難しいこと、読解力の差が点数へ与える影響を排除すること等を鑑み、次のような手順で行った。

- ✓ 筆記試験では試験官が各問題を口頭で読み上げて、問題 1 から順番に行く。
- ✓ 試験官が 2 回問題文を読み上げた後、児童はその問題を回答する。
- ✓ 決められた回答時間が経過したら、試験官が次の問題に進む指示を出し、次の問題の問題文を読み上げるという流れで実施した。
- ✓ またカンニング等を防ぐため、隙間を空けて児童を着席させ、複数の研究者が児童の様子を確認しながら調査を実施した。

このテスト実施方法も、冒頭に上げた「社会文化的な影響があり極めて深刻な学習貧困の状態が見られる国における、エビデンスに基づく内発的アプローチ (Baba & Nkhata, 2026)」の具体例の一つとなった。

2.2.4 ワークショップの実施

調査前に2回のワークショップを実施した。1回目のワークショップは、実験群および統制群の全10校対象としてプロジェクトの概要説明およびフェーズIの介入活動の復習を行った。2回目のワークショップは、実験校5校のみを対象とし、フェーズIIの介入活動の説明を行った。詳細を以下に記載する。

<第1回ワークショップ>

日程: 2024年2月23日

場所: ザンビア大学

目的: フェーズIの介入活動の振り返り、およびプロジェクト全体の概要説明

主な参加者: Dr. Bentry Nkhata (ザンビアチームリーダー、UNZA), Dr. Liberty Mweemba (教育学部長、UNZA), Ms. Shelly Sikwale (ザンビア教育省代表), Prof. Takuya Baba (プロジェクトリーダー、広島大学), Ms. Barbara Mudenda & Mr. Bareford Mambwe (リサーチアシスタント), Dr. Patricia Nalube (ザンビアチーム サブリーダー、UNZA)

内容: フェーズIの活動の振り返りが行われ、今後の改善点や課題が共有された。参加者は、実施された活動の成果を確認し、次のフェーズに向けた議論を行った。

<第2回ワークショップ> (図4)

日程: 2024年3月25日

場所: ザンビア大学

目的: 実験群の教員へのフェーズIIの介入活動内容の説明

主な参加者: Dr. Bentry Nkhata (ザンビアチームリーダー、UNZA), Ms. Shelly Sikwale (ザンビア教育省代表), Ms. Barbara Mudenda, Mr. Bareford Mambwe, Mr. Emmanuel Kaa, Ms. Doye Chikola, Ms. Spiwe Tafeni (リサーチアシスタント), Dr. Patricia Nalube (ザンビアチーム サブリーダー、UNZA), Dr. Satoshi Kusaka (チームメンバー), 実験群5校の校長および担当教員

内容: 実験群の対象教員を対象に教育的介入で使用するワークブックについて説明した。はじめに、日下が調査の概要およびワークブックの全体の構造について説明した後、参加者をグループに分けて、リサーチアシスタントがそれぞれのタスクの詳細について説明した。各タスクの説明に十分な時間を確保し、実際の教材(タイル、グリッド、数直線)を用いて説明することにより、教員の理解を深めることができた。

図4 第2回ワークショップの様子:





2.2.5 事前事後調査 (図 5, 6)

事前、事後調査は 2024 年 1 月から実施することが計画されていたが、コレラの感染拡大による学校の休校を受けて延期を余儀なくされた。学校が 2 月に再開したことを受け、事前調査を 3 月末から始めることとした。(表 11, 表 12)

実施方法に関しては、ザンビアチームおよび日本チームの数名が学校にて対面でインタビューを実施した。日本チームは日本からオンラインでも調査に参加し、その日の最後にインタビューの評価結果について、合同で検討した。すでにインタビューガイド作成過程で基礎となる考え方は共有されていたため、判断が揺れた場合も、判断基準に戻って考えることで最終的な判断ができた。調査中、児童たちの不安を取り除くためクラス担当教員は在室したが、調査に直接参加することはなかった。

表 11 事前調査実施日程 2024 年 3 月～4 月

Sun	Mon	Tue	Wed	Thu	Fri	Sat
3/24	25	26 School A (I) School B (T)	27 School B (I) School A (T)	28 School C (I) School D (T)	29	30
31	4/1	2 School D (I) School C (T)	3 School E (I) School F (T)	4 School F (I) School E (T)	5 School G (I) School H (T)	6
7	8 School H (I) School G (T)	9 School I (I) School J (T)	10 School J (I) School I (T)			

表 12 事後調査実施日程 2024 年 6 月～7 月

Sun	Mon	Tue	Wed	Thu	Fri	Sat
6/23	24 School C (I) School B (T)	25 School B (I) School C (T)	26 School I (I) School J (T)	27 School J (I) School I (T)	28 School E (I) School D(T)	29 School D (I)
30	7/1	2 School G (I)	3 School F (I) School E (T)	4 School A (I) School F (T)	5 School H (I) School A (T)	6
7	8 School H (T)	9 School Gb (T)				



図 5 事前調査の様子



図 6 事後調査の様子

2.2.6 研究対象者とインタビューでのタスクの関係

調査時間の関係で、全学年にすべてのタスクに回答させることは断念した。他方で学年間の比較が可能になるように、問題内容を学年によらず同一の問題とし、回答する問題の幅を学年によって変えた（表13）。また整数の1.1 から1.5 までを共通タスクとした。

表 13 調査タスクと学年の対応関係

	Natural Number												Decimal Number											
	1					2			3				1					2			3			
	1	2	3	4	5	1	2	3	a	s	m	d	1	2	3	4	5	1	2	3	a	s	m	d
3年																								
4年																								
5年																								
6年																								

2.2.7 教育的介入

事前、事後調査の間に、教育的介入が計画された。3回の現地調査、事前事後調査においては、ヒントを与えることなく児童たちの状況をありのままに記述するのに対して、介入においては、クラス担当教員に介入ツールを用いた教育的介入をお願いした。そのことは、児童と教員の信頼関係が基になっているという点で重要なことである。介入ツールは、児童たちに冊子（児童用ワークブック）、教員に教師用ガイドを配布したものを指している。

介入時期は、事前、事後調査の間に、ちょうどその間に休暇があった。教育省とも相談の上、スケジュールを決めた(表 14)。教員は、スケジュール通りの授業を行い、特に休暇期間中に集中的に取り組むことが可能となった。全 38 日間の中でワークブックを 2 周もしくは 3 周するように計画された。

また、介入の期間中は、定期的にザンビアチームが学校を巡回し、教員の活動をモニタリングした。すでに教員はワークショップにおいて、児童用ワークブックと教師用ガイドの使用法の概要をつかんでいるものの、特定の教材の要所や実際の使用について理解が十分でなかったりした。実際のところ、このように打ち合わせ、ヒアリングを行い、また使うこと

で、教員は時間とともにその方法を学んでいった²。

なお、事前、事後調査のツール（テスト、インタビューガイド）は全く同一のものを使用したが、加えて介入ツールもほぼ対応しているものであった。

² Zoom を通して、日本から観察したが、教員の介入は素晴らしいものもあり、今後の教育活動に使えると考えている。

表 14 教育的介入の実施日時

G3,4

Competence	Task	Date (1st rotation)	Date (2nd rotation)	Date (3rd rotation)		
1. Representation	Extra A					
	Practice 1	1	Apr 15	14	May 17	
	Practice 2					
	Extra B	2	Apr 16	15	May 20	
	Practice 3					
	Practice 4	3	Apr 17	16	May 21	
	Practice 5					
	Extra C	4	Apr 18	17	May 22	
3. Calculation	Extra D					
	Extra H	5	Apr 19	18	May 23	DAY 32-38 (Jun13-Jun21)
	Extra I	6	Apr 29	19	May 24	
	Practice 9	6	Apr 29	20	May 27	Review Teacher selects units that pupils lack understanding of and reviews them.
	Practice 10	6	Apr 29	21	May 28	
	Extra J	7	Apr 30	22	May 29	
	Practice 11	7	Apr 30	23	May 30	
	Extra K	8	May 2	24	May 31	
	Extra L	8	May 2	25	Jun 3	
	Practice 12	8	May 2	26	Jun 4	
	Practice 13	9	May 3	27	Jun 5	
	Practice 14	9	May 3	28	Jun 6	
	2. Comparison	Extra E	10	May 13	29	Jun 7
		Practice 6				
Extra F		11	May 14	30	Jun 10	
Practice 7						
Extra G		12	May 15	31	Jun 11	
	Practice 8	13	May 16			

G5,6

Competence	Task	Date (1st rotation)		Date (2nd rotation)		
1. Natural number representation	Extra NA Practice N1	1	Apr 15	15	May 21	
	Extra NB Practice N2	2	Apr 16	16	May 22	
2. Decimal number representation	Extra A Practice 1 Practice 2	3	Apr 17	17	May 23	
	Extra B Practice 3	4	Apr 18	18	May 24	
	Practice 4 Practice 5	5	Apr 19	19	May 27	
	Extra C Extra D	6	Apr 30	20	May 28	
	4. Calculation	Extra H (Natural)			21	May 29
		Extra H' (Decimal)	7	May 2	22	May 30
Extra I (Natural)				23	May 31	
Extra I' (Decimal)		7	May 2	24	Jun 3	
Practice 9		7	May 2	25	Jun 4	
Practice 10		7	May 2	26	Jun 5	
Extra J (Natural)				27		
Extra J' (Decimal)		8	May 3	28	Jun 7	
Practice 11		8	May 3	29	Jun 10	
Extra K (Natural)				30		
Extra K' (Decimal)		9	May 13	31	Jun 12	
Extra L		9	May 13	32	Jun 13	
Practice 12		10	May 14	33	Jun 14	
Practice 13		10	May 14	34	Jun 17	
Practice 14	11	May 15	35	Jun 18		
3. Comparison	Extra E	12	May 16	36	Jun 19	
	Practice 6	12	May 16	36	Jun 19	
	Extra F	13	May 17	37	Jun 20	
	Practice 7	13	May 17	37	Jun 20	
	Extra G	14	May 20	38	Jun 21	
	Practice 8	14	May 20	38	Jun 21	

第 3 章 分析結果

3.1. データ処理の方法

3.1.1. インタビューデータ

インタビューは、インタビューガイド（ANNEXI-1）を参照しながら行った。面接者とは別に複数名の評価者が付き、児童の各問題（タスク）に対する反応の評価を行った。評価者間で評価点が異なる場合は、インタビュー内容を振り返り、最終的な評価点を決定した。その最終的な評価点をエクセルに入力し、インタビューに関する分析用データセットを作成した。

3.1.2. テストデータ

児童の解答の情報を可能な限り抽出するために、正誤を入力するのではなく、解答そのものや解答を分類するコードを入力した。表 15 にコードの一部を示した。

表 15 入力コードの一部

item	正答		コード	
q1	270	解答をそのまま入力	88：無回答	99：解読不能
q2	420	矢印で示された数を入力	88：無回答	99：解読不能
q3	180	解答をそのまま入力	88：無回答	99：解読不能
q4(1)	260	枠で囲まれた数を入力	88：無回答	99：解読不能

3.2 インタビューの分析結果

表 16 に示す通り、調査対象者の数は、事前・事後インタビューともに 40 名の児童であった。

表 16 インタビュー対象者の情報

	合計	実験群	統制群
3年生	20名	10名	10名
4年生	20名	10名	10名
5年生	20名	10名	10名
6年生	20名	10名	10名
合計	80名	40名	40名

3.2.1 各学校における得点の変化・成績上位群と中位群による得点の変化

各学校における事前事後インタビューの平均値は表 17 の通りであった。実験群の George Central および Chamba Valley においては平均値の変化があまり見られなかった。George Central では教員の欠勤が多く、特に 3 年生の担任が長期間不在で活動の大幅な遅れが見られた。また、ワークブックの配布の遅れや教師間の連携不足など、学校内での情報共有にも課題があった。こうした不安定な状況が、結果に影響を与えた可能性がある。Chamba Valley

は事前調査の平均値が高く、変化があまり見られなかった可能性がある。その要因として、Chamba Valley はフェーズ I の初期から参加している実験群の学校であり、学校として基礎学力の底上げが達成できている可能性がある。ここから、フェーズ II だけでなく、フェーズ I からの積み重ねが児童の学習結果にも良い影響を与えていることが示唆される。

表 17 各学校における事前事後インタビューの得点

種別	学校名	事前調査	事後調査	差
control	Kaunda Square	2.75	3.40	0.65
control	Chipata	2.67	3.32	0.65
control	Muchinga	2.23	2.67	0.44
control	John Laing	3.24	3.48	0.24
control	Chimwemwe	2.09	2.68	0.59
experimental	Twashuka	2.53	3.48	0.95
experimental	New Kabanana	3.06	4.08	1.02
experimental	George Central	2.36	2.84	0.48
experimental	Chamba Valley	3.58	3.99	0.41
experimental	New Kamulanga	2.51	3.89	1.38

また、成績上位群と下位群におけるインタビュー得点の変化は表 18 の通りであった。ここでは、事前調査において得点が低かった児童を中位、高かった児童を高位として、インタビュー得点の変化を見た。統制群においては、成績群によって得点の差に大きな変化は見受けられなかった。一方、実験群においては、統制群よりも伸びが大きく、成績中位群のほうが事前と事後の平均値の差が大きかった。

表 18 成績群における事前事後のインタビュー得点

種別	成績	事前調査	事後調査	差
control	中位	2.11	2.73	0.62
	上位	2.97	3.54	0.57
experimental	中位	2.24	3.31	1.08
	上位	3.18	3.89	0.71

3.2.2 各学年におけるインタビュー得点の変化

各学年における実験群と統制群の事前事後インタビュー得点の変化を比較するため、差分の差分(DiD)分析(重回帰分析)を実施した。また、自然数の1.1 から1.5の5問は3年生から6年生までの全学年の児童に共通するため、共通タスクにおける結果も示した。

表 19 各学年におけるインタビュー得点の平均値および差分の差分分析
(重回帰分析の結果)

学年	クロンバック α 係数			統制群		実験群		重回帰分析の結果			
	全体(40)	事前調査(20)	事後調査(20)	事前調査(20)	事後調査(20)	事前調査(20)	事後調査(20)	偏回帰係数	標準誤差	t値	p値
3	0.85	0.76	0.85	2.41	3.34	2.00	3.28	0.33	0.39	0.85	0.40
4	0.80	0.80	0.71	2.50	3.08	2.63	3.37	0.44	0.58	0.76	0.45
5	0.84	0.80	0.80	2.73	3.38	3.02	4.05	0.38	0.50	0.75	0.45
6	0.92	0.91	0.92	2.49	2.75	3.19	3.45	0.00	0.66	0.00	1.00
3-6(共通項目5問)	0.79	0.80	0.73	2.70	3.20	3.01	3.84	0.33	0.39	0.85	0.40

クロンバック α 係数は0.8前後であり、タスクの内的妥当性は確保されていると判断した。各学年におけるインタビュー得点および分析の結果は表19の通りである。重回帰分析の結果、実験群における介入の効果は統計的に有意ではなかった。

3.2.3 各タスクにおけるインタビュー得点の変化

次に、各タスクの得点および平均値の変化について着目する。表 20 において、介入効果の推定値が 1.0 以上のものを赤字、0.1 以下のものを青字で示す。ここでは、介入効果の推定値が 1.0 以上のものを変化が大きいタスクとし、0.1 以下のものを小さいタスクとして考察する。

表 20 各インタビュータスク項目の得点および差分の差分分析

問題	統制群		実験群		差		介入効果 の推定値	
	事前調査	事後調査	事前調査	事後調査	統制群	実験群		
整数	1.1	2.23	2.45	2.85	3.41	0.23	0.56	0.34
	1.2	2.63	2.64	3.05	3.75	0.02	0.70	0.68
	1.3	3.28	4.38	3.15	4.10	1.09	0.95	-0.14
	1.4	2.23	3.30	2.30	3.50	1.08	1.20	0.13
	1.5	3.33	3.43	3.68	4.45	0.10	0.78	0.68
	2.1	3.00	4.00	2.70	3.50	1.00	0.80	-0.20
	2.2	3.40	4.30	2.80	4.00	0.90	1.20	0.30
	2.3	2.80	3.30	2.10	2.70	0.50	0.60	0.10
	3a	3.40	4.00	3.60	4.30	0.60	0.70	0.10
	3s	2.30	3.50	2.80	3.80	1.20	1.00	-0.20
	3m	1.20	1.80	1.20	2.00	0.60	0.80	0.20
	3d	1.20	1.40	1.00	1.89	0.20	0.89	0.69
	小数	1.1	2.95	4.05	3.30	4.35	1.10	1.05
1.2		1.15	1.55	1.50	3.30	0.40	1.80	1.40
1.3		3.00	3.15	3.65	4.05	0.15	0.40	0.25
1.4		2.15	3.25	2.45	3.40	1.10	0.95	-0.15
1.5		3.50	4.10	4.10	4.70	0.60	0.60	0.00
2.1		2.27	3.20	2.70	3.30	0.93	0.60	-0.33
2.2		3.45	3.30	2.67	3.60	-0.15	0.93	1.09
2.3		2.55	3.00	2.40	3.40	0.45	1.00	0.55
3a		1.90	2.40	2.30	3.10	0.50	0.80	0.30
3s		2.40	2.50	3.30	3.80	0.10	0.50	0.40
3m		1.40	1.80	2.00	2.10	0.40	0.10	-0.30
3d		1.40	1.30	1.90	1.78	-0.10	-0.12	-0.02

各タスクにおける介入効果の推定値により、小数タスク 1.2, 2.2 は介入効果が現れやすいタスクだと考えられる。逆に介入効果が見られなかったのは、整数におけるタスクは 1.3, 2.1, 2.3, 3a, 3s、小数における 1.1, 1.4, 1.5, 2.1, 3m, 3d であった。

介入の効果が現れた各タスクについて検討すると、小数タスク 1.2(1)は図 7 の数直線において各目盛が表す数を答える問いであった。小数タスク 2.2 は 3.5 と 1.6 を図 8 に示すような 10 のタイル、1 のタイル、0.1 のタイルで表し、どちらの数のほうが大きいかわかる問いであった。小数における数直線は第 6 学年の教科書に記載されており、またタイルに関しては教科書には掲載されていない。そのため、ザンビアの児童にとってはなじみが薄く、介入によって効果が大きく現れた可能性が考えられる。



図 7 小数タスク 1.2(1)における数直線



図 8 小数タスク 2.2 におけるタイル

介入効果が見られなかったタスクについて検討すると、整数タスク 1.3 は図 9 の数直線において矢印が示す数を答える問いであった。また、整数タスク 2.1 は[400, 80, 210]を小さい順に並べ替える問いである。整数タスク 2.3 は数直線上に[50, 370, 160]を示す問いである。整数タスク 3a は $330+135$ をひっ算で解く問いで、整数タスク 3s は $385-152$ をひっ算で解く問いである。また、小数タスク 1.1 は図 10 の数直線において矢印が示す数を答える問いである。小数タスク 1.4 は 10 のフレームが 1 を表す際に、図 11 において赤線で囲まれた数を答える問いである。小数タスク 1.5 は 10 のフレームが 1 を表す際に、2.6 を囲う問いである。小数タスク 2.1 は[1.2, 0.8, 2.1]を小さい順に並び変える問いである。小数タスク 3m は 2.4×3 をひっ算で解く問いで、小数タスク 3d は $3.6 \div 3$ をひっ算で解く問いである。

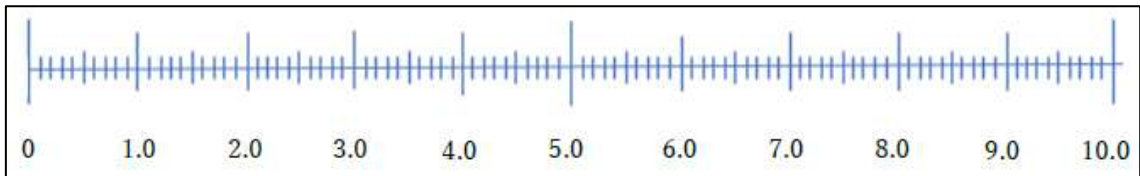
整数タスク 1.3, 2.1, 2.3, 3a, 3s および小数タスク 1.1, 1.4, 1.5, 2.1 では統制群および実験群において得点の向上が見られることから、3 カ月間における通常の授業等において児童の理解が深まった可能性が考えられる。一方、小数タスク 3m および 3d は両群ともに得点の向上はみられず、介入が必ずしも有効に機能していないといえる。

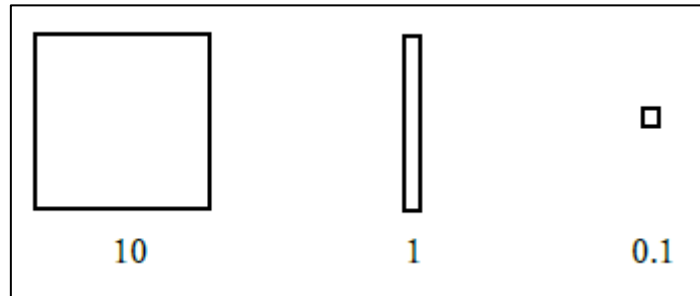

図 9 整数タスク 1.3 における数直線



図 10 小数タスク 1.1 における数直線

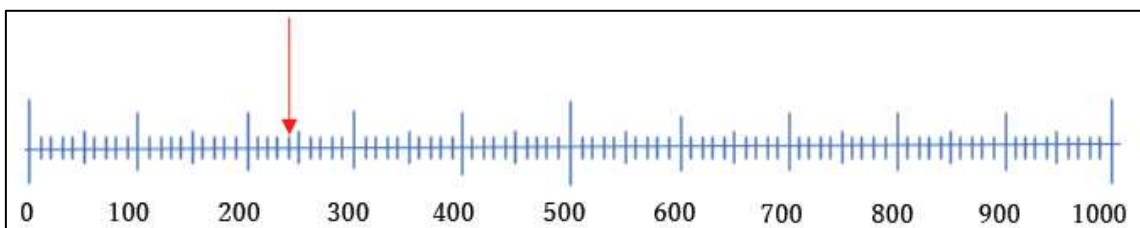

図 11 小数タスク 1.4

3.2.4 事前事後インタビューを受けた個々の児童の変化

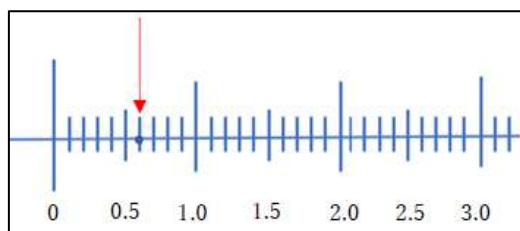
事前事後インタビューを受けた個々の児童の変化について検討する。ここで各学年の個別の児童について、最もスコアが上昇した児童に注目することにした。

(1) 第3学年

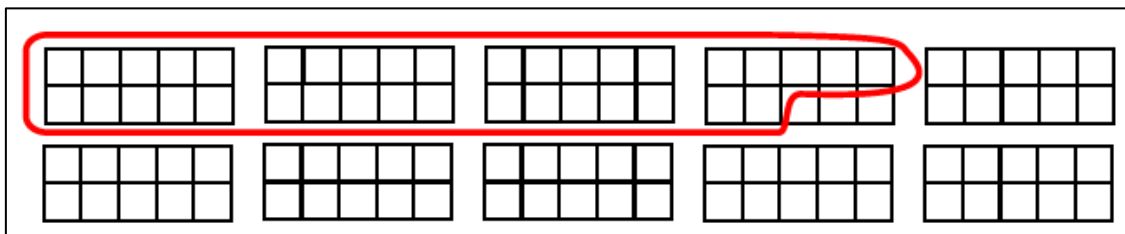
統制群と実験群のスコアを比べた結果、事後でスコアが下がった児童が実験群で2名いた。それぞれ、1.38から1.25の変化と4.0から3.0の変化であった。これらの児童2名は問題を解くことができていないことがわかる。それ以外の児童では、2.0ポイント以上上昇した児童が実験群で4名いるが、統制群ではない。統制群では1ポイント以上上昇した児童が5名、実験群では6名いた。このことから、実験群の児童の伸びは統制群の児童の伸びよりも大きいと言える。また、2.0ポイントの上昇からも、介入の効果がみられることがわかる。実験群の児童の中で最も点数が上昇した児童は2名おり（表21、表22）、彼らのポイントの変化はそれぞれ1.63から4.13、1.8から4.3であった。これらの児童の特徴として、すべての問いにおいて、誤答から正答になっていることがわかる。

表 21 第3学年における改善が最も大きかった児童 A（すべて自然数の問）

第1学年	1.1	1.2	1.3	1.4	1.5	2.1	2.2	2.3
事前	1	4	2	1	1	1	1	2
事後	5	5	2	4	5	4	4	4

（列はタスク番号）

表 22 第3学年における改善が最も大きかった児童 B（すべて自然数の問）

第1学年	1.1	1.2	1.3	1.4	1.5	2.1	2.2	2.3
事前	2	2	1	1	1	4	1	2
事後	5	2	5	5	5	4	5	3

（列はタスク番号）

児童 A(全体で 2.5 ポイント上昇)に関して、数値上では改善しているように見えるため、改善があまりみられない部分に着目した。タスク 1.3 においては変化なしの 2.0 ポイントであった。この問題は数直線上に示された 240 を読み取る問題で、誤答であった。数直線上に関連した問題はタスク 1.1 と 1.2 であり、そこでは 5.0 ポイントのため、数直線についての基本的な把握はできている。そのほかの 4.0 ポイントであった問題は、グリッドで数量の大きさを変換して表す問い(タスク 1.5)や数量の大きさの比較の問題であった。

児童 B(全体で 2.5 ポイント上昇)に関しても、児童 A と同様に改善がみられなかったタスクについて注目する。タスク 1.2 が変化なしで 2.0 ポイントであった。この問題は数直線で 260 の位置を示す問いで、改善が見られなかった。他の数直線関連の問いはできているため、原因は不明である。他には、タスク 2.1 において 4.0 ポイント、タスク 2.3 において 3.0 ポイントであった。両方の問題では 3 つの数の大きさ比べを取り扱っていた。言語的な説明が難しいという結果が出ているが、事後においてはタスク 2.3 については正答できるようになっている。これらのことから、数直線の把握ができるようになっていても、問題によっては誤答になる場合もあることがわかる。このことはザンビア人児童の計算や数パターンの把握を調査した澁谷(2009)において述べられているように、問題が正答した場合でも、揺り戻しで誤答に戻ったり、あるいは理解が不安定であったりすることにも類似している様相であると考えられる。このように改善が大きくみられた児童は、説明することができるようになっていくことがわかり、ここに学習の成果が見られる。その一方で、理解の不安定性や揺り戻しが見られることもわかり、ザンビア人児童の学習の特徴や困難性をこの調査においても改めて確認することができる。

(2) 4 年生

統制群と実験群のスコアを比べた結果、事後でスコアが下がった児童が実験群で 1 名いた。その児童のスコアの変化は 2.33 から 2.22 の結果であった。それ以外の児童では、2.0 ポイント以上上昇した児童が実験群では 1 名おり、統制群ではない。統制群では 1.0 ポイント以上上昇した児童が 3 名、実験群では 4 名いた。このことから、実験群の児童の伸びは統制群の児童の伸びより大きい、第 3 学年に比べても第 4 学年のポイントの伸びは小さいと推測できる。実験群の児童の中で最も点数が上昇した児童(表 23)のポイントの変化は 2.3 から 4.6 であった。

表 23 第 4 学年における改善が最も大きかった児童 B(すべて自然数の問)

第4学年	1.1	1.2	1.3	1.4	1.5	3a	3s	3m	3d
事前	2	5	1	1	3	5	2	1	1
事後	5	5	5	5	5	5	5	1	5

(列はタスク番号)

この児童の結果から、タスク 3m を除き、全て言語的な説明ができるようになっている。タスク 3m については 240×3 の筆算、 240×3 の具体物による操作と説明に関する問題である。どの内容も誤答で、それは事前事後で変化していない。他の児童の結果も、事前事後で

統制群より実験群の児童において、スコアが高い児童が多いものの（事後において3.0ポイント以上の児童は統制群で1名、実験群で3名）、全体的に1.0や2.0のスコアが多く見られる。そのため、この児童も含めて、(3桁)×(1桁)に関しては、インタビューにおいては介入の効果が見られなかったと言えるかもしれない。その原因として、数が大きくなると、具体物を用いた操作が難しくなることや、同数累加の考え方から脱する方向性に向いていかないと倍の考え方に結びついていかないことなどがあるのかもしれない。中和(2012)においては、初等段階の児童たちのかけ算九九の習熟状況が報告されているが、(1桁)×(1桁)の乗法であっても、初等～中等教育段階のザンビア人児童たちは定着していないことがわかっている。このことから(3桁)×(1桁)に困難を抱える3-6学年の児童たちは一定数いると推測できる。調査で用いたツールは数の大きさを可視化することができるため、数感覚を養うためには有効であると考えられる。しかしながら、計算のスキルを把握させ定着させるためには、別の方策についても取り組み、介入効果を実証的に確認することが必要であると考ええる。

(3) 第5学年

統制群と実験群のスコアを比べた結果、事後でスコアが下がった児童が統制群で1名いた。その児童のスコアの変化は2.46から2.15の結果であった。それ以外の児童では、2.0ポイント以上上昇した児童が実験群では1名おり、統制群ではない。統制群では1.0ポイント以上上昇した児童が2名、実験群では4名いた。このことから、実験群の児童の伸びは統制群の児童の伸びは大きいですが、第3学年に比べて伸びは小さく、また第4学年と傾向が類似していると推測できる。実験群の児童の中で最も点数が上昇した児童(表24)のポイントの変化は2.3から4.6であった。統制群よりも実験群の方が事前事後の差で見ると、良い結果になっているものの、第3,4学年に比べて、差が少なく、介入の効果が大きく見られなかったことがわかる。

表 24 第5学年における改善が最も大きかった児童

第4学年	自然数					小数								
	1.1	1.2	1.3	1.4	1.5	1.1	1.2	1.3	1.4	1.5	2.1	2.2	2.3	
事前	1	1	1	1	1	5	1	2	1	1	4	1	4	
事後	5	5	5	4	5	5	5	2	1	4	4	5	5	

(列はタスク番号)

この児童も第4学年の伸びが最も大きかった児童の様相に類似している。タスク1.3と1.4の結果を除き、全ての項目で正答し、4.0か5.0ポイントであるため、説明を行うことが大方できるようになっていることがわかる。また、整数と小数の結果を比較しても、大差はなく、数の種類に影響されていないことがわかる。この結果は成果として前向きに捉えることができる。しかしながら、唯一、タスク1.4が1.0ポイントであった。これは、2×5の長方形のます10個に対して、全体が1だった場合に、1つの立方体の大きさを求める問題であった。この問題に対しては、割合的な見方や、単位を捉える見方が必要になるが、改善が見られなかった。その一方で、他の小数の問題については全て正答している。このことから

も、小数に関しての把握は介入により改善されているものの、未だ、割合的な見方、単位の捉え方に改善の余地があると推測できる。

(4) 第6学年

統制群と実験群の児童のスコアを比べた結果、事後でスコアが下がった児童が実験群で2名、統制群で4名いた。その児童のスコアの変化は実験群でそれぞれ、4.57から4.14、4.64から4.57、統制群で3.57から3.50、2.43から1.92となっている。このことから、この学年においては、スコアが下がった児童が最も多い結果となった。しかしながら、実験群の2名、統制群の1名はスコアの変化が少ないとも言える。実験群の児童2名は、平均値が4.0ポイント以上となっており、元々正答が多く、説明ができるレベルであることがわかる。

それ以外の児童では、2ポイント以上上昇した児童は両群においていない。統制群では1ポイント以上上昇した児童が2名、実験群ではおらず、差が1未満であった。このことから、他の学年の結果に比べても、介入の効果が少ないことが推測できる。実験群の児童の中で最も点数が上昇した児童(表25)のポイントの変化は3.93から4.86であった。この児童は例外的に、他の児童と比較しても、事前の平均値が高いことがわかり、約1.0ポイント上昇している。しかしながら、実験群の他の児童の事前事後の差は、他の学年に比べても小さく、概念が難しくなるにつれ、介入の効果が見られにくいことが伺える。

表 25 第6学年における改善が最も大きかった児童B

第6学年	自然数					小数								
	1.1	1.2	1.3	1.4	1.5	1.1	1.2	1.3	1.4	1.5	3a	3s	3m	3d
事前	5	5	5	5	5	5	2	4	4	5	2	5	2	1
事後	5	5	5	5	5	5	5	5	5	5	4	5	5	4

(列はタスク番号)

この児童は、タスク3aとタスク3dを除けば、全ての問題において説明を行うことができるようになっており、成果が見られる。4.0ポイントであったタスク3(a)とタスク3(d)に関しては、問題は類似しており、小数の加法と除法の計算と具体物を用いた操作と説明であったが、こちらも、若干の改善点が残るものの、事前の結果よりも改善されていることがわかる。伸びが大きかった児童の結果、特に、5,6年生の児童に関しては、伸びが大方大きいことは成果として見取れるが、網羅的に理解しているというよりも、個々人で苦手な部分が残っており、そこには上述の不安定性があることも指摘できる。それは日本でいう定着・長期記憶の必要性(湯澤,2019)が示唆される。

3.3 テストの分析結果

第3・4学年と第5・6学年を対象にそれぞれ異なるテストを用いて調査を行った。第3・4学年のテストは整数とその四則計算に関するものであり、第5・6学年は小数とその四則計算に関するものである。

統制群と実験群には、それぞれ5校あり、各学校のサンプルサイズを表26に示した。各学校約40名が参加し、事前事後調査の第3・4学年と第5・6学年の合計はそれぞれ798名

と 803 名である。また、事前事後調査とともに参加したサンプルサイズは、それぞれ 324 名と 317 名である。

表 26 サンプルサイズ

group	School	G3&4			G5&6		
		pre	post	common	pre	post	common
control	Chimwemwe	40	40	32	40	40	33
	Chipata	40	40	34	41	40	33
	JohnLaing	40	40	35	40	40	35
	Muchinga	40	40	33	40	40	26
	KaundaSquare	38	40	33	40	40	33
experimental	ChambaValley	40	40	36	40	40	32
	GeorgeCentral	40	40	30	40	40	32
	NewKabanana	40	40	26	41	41	32
	NewKamulanga	40	40	34	40	40	33
	Twashuka	40	40	31	40	40	28
Total		398	400	324	402	401	317
		798			803		

第 3・4 学年の分析

出題問題の概要を表 27 に示した。ここでは、正答率が 5%以下で、他の問題と比べて特に正答率が低い問 10 と問 11 を除き、残り 18 問に着目して、分析を進める。また、正答に着目した分析を行う。

表 27 第 3・4 年生のテスト問題

問題	内容
1	数直線上に示された数を答える。
2	数直線上に 420 の場所を示す。
3	区分けありの 100 の枠を基に囲まれた部分の数を答える。
4(1)	区分けありの 100 の枠を囲って 260 を示す。
4(2)	区分けなしの 100 の枠を囲って 490 を示す。
5(1)	100 の四角を 2 つ描く。
5(2)	10 の長四角を 3 つ描く。
5(3)	1 の四角を 4 つ描く。
6	区分けありの 100 の枠で示された 360 を数直線上に示す。
7	100 の四角、10 の長四角、1 の四角から数の大きさ比べる。
8	数直線上に示された 2 つの数の大きさを比べる。
9(1)	240 と 280 と書かれた数の大きさを比べる。

- 9(2) 350 と 620 と書かれた数の大きさを比べる。
- 10(1) たし算 $120+120+120+120=480$ をかけ算で表す。
- 10(2) 3×210 の図を描く。
- 11(1) 480 を 4 つに分けることをわり算で表す。
- 11(2) $390 \div 3$ の図を描く。
- 12(a) $178+213$
- 12(b) $286-147$
- 12(c) 230×3
- 12(d) $480 \div 4$
- 13 $360 \div 3$ の立式と計算をする。

まず、各問題に対して、正答を 1、誤答を 0 と変換し、2 値データを作成した。それに対して、クロンバック α 信頼係数を算出したところ、0.865 を示した。したがって、この 18 問の信頼性はある程度確保されていると判断した。

そこで、統制群と実験群におけるテスト得点の分布を確かめた (図 12)。また、その記述統計量が表 28 である。統制群では、事前事後において 2.316(=8.685-6.369) 点向上している。その一方で、実験群においては、それよりも大きい 5.00(=5.210-10.210) 点の向上がみられた。



図 12 第 3・4 年生における統制群と実験群のテスト得点の分布

表 28 テスト得点の分布の記述統計量

	control		experimental	
time	average	sd	average	sd
pre	6.369	3.402	5.210	2.943
post	8.685	4.160	10.210	4.286

第 5・6 学年の分析

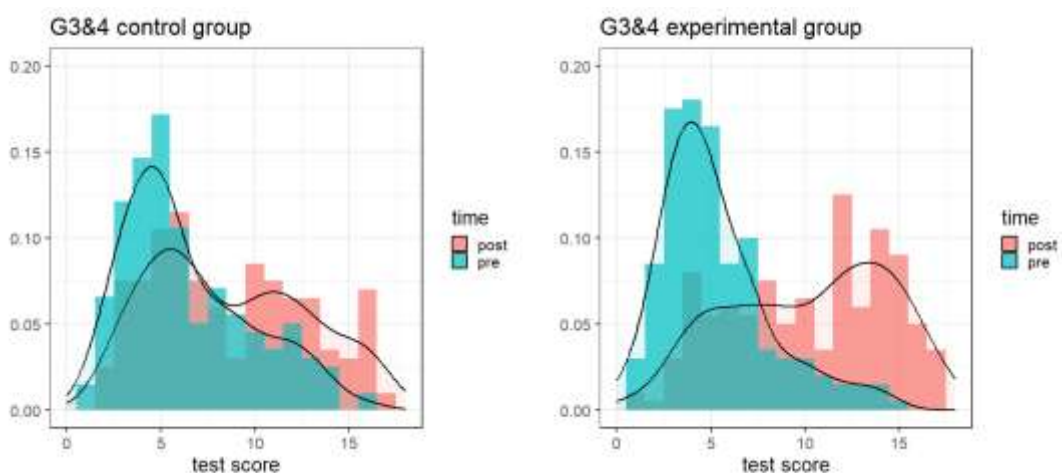
出題問題の概要を表 29 に示した。ここでは、正答率が 5%以下で、他の問題と比べて特に正答率が低い問 13~16 問を除き、残り 17 問に着目して、分析を進める。また、第 3・4 学年と同様に、正答に着目した分析を行う。

表 29 第 5・6 学年のテスト問題

問題	内容
1	数直線上に 420 の場所を示す。
2	区分けありの 100 の枠を囲って 260 を示す。
3(1)	100 の四角を 2 つ描く。
3(2)	10 の長四角を 3 つ描く。
3(3)	1 の四角を 4 つ描く。
4	数直線上に 4.2 の場所を示す。
5	数直線上に示された数を答える。
6	区分けありの 1 の枠を基に囲まれた部分の数を答える。
7	区分けありの 1 の枠を囲って 2.6 を示す。
8(1)	10 の四角を 2 つ描く。
8(2)	1 の四角を 3 つ描く。
8(3)	0.1 の長四角を 4 つ描く。
9	区分けありの 1 の枠で示された 3.6 を数直線上に示す。
10	10 の四角、1 の長四角、0.1 の四角から数の大きさ比べる。
11	数直線上に示された 2 つの数の大きさを比べる。
12(1)	2.4 と 2.7 と書かれた数の大きさを比べる。
12(2)	1.8 と 3.4 と書かれた数の大きさを比べる。
13(1)	たし算 $1.2+1.2+1.2+1.2=4.8$ をかけ算で表す。
13(2)	3×2.1 の図を描く。
14(1)	4.8 を 4 つに分けることをわり算で表す。
14(2)	$3.9 \div 3$ の図を描く。
15(a)	$17.8+21.3$
15(b)	$28.6-14.7$
15(c)	2.3×3
15(d)	$4.8 \div 4$
16	$18.6 \div 3$ の立式と計算をする。

まず、各問題に対して、正答を 1、誤答を 0 と変換し、2 値データを作成した。それに対して、クロンバック α 信頼係数を算出したところ、0.889 を示した。したがって、この 22 問の信頼性はある程度確保されていると判断できる。

そこで、統制群と実験群におけるテスト得点の分布を確かめた (図 13)。また、その記

述統計量が表 30 である。統制群では、事前事後において 2.552(=8.965-6.413)点向上している。その一方で、実験群においては、それよりも大きい 5.572(=12.861-7.289)点の向上がみられた。



図 13 第 5・6 年生における統制群と実験群のテスト得点の分布

表 30 テスト得点の分布の記述統計量

	control		experimental	
time	average	sd	average	sd
pre	6.413	3.885	7.289	4.032
post	8.965	4.439	12.861	3.510

統制群と実験群におけるテスト得点の平均値の変化

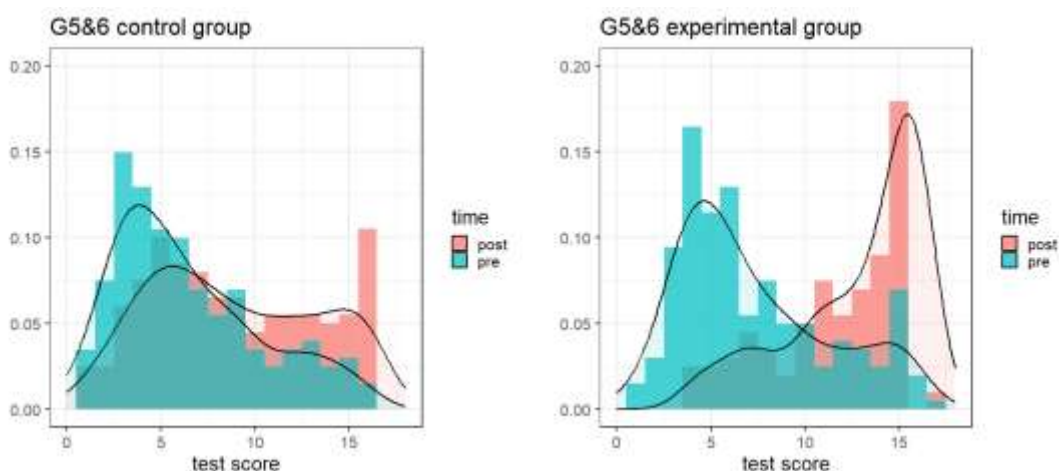
図 14 に、表 30 に示した統制群と実験群における事前事後のテスト得点の平均値の変化を示した。このように、第 3・4 学年と第 5・6 学年ともに実験群の方が統制群よりも得点の向上が大きいと考えられる。

そこで、差分の差分分析を行い、介入効果の大きさについて調べた。表 31 をみると、第 3・4 学年と第 5・6 学年における介入効果の大きさは、それぞれ 2.684 と 3.120 であった。これは、事前事後において、実験群の方が統制群よりも 3 問程度正答する問題が増える効果の大きさと考えられる。



図 14 統制群と実験群における事前事後のテスト得点の平均値の変化

表 31 差分の差分分析の結果

	3・4年生			5・6年生		
	推定値	SE	p 値	推定値	SE	p 値
定数項	6.369	0.266	<0.00	6.413	0.281	<0.00
事後	2.316	0.375	<0.00	2.452	0.398	<0.00
実験群	-1.159	0.375	<0.05	0.876	0.397	<0.05
介入効果	2.684	0.530	<0.00	3.120	0.562	<0.00

また、どの問題に介入効果がみられるかを検討した。表 32 と表 33 をみると、多くの問題に介入効果がみられる。例えば、第 3・4 学年の問題 1 をみると、実験群の事後、つまり介入によって、4 倍正答する割合が増加したことが分かる。これにより、介入効果がみられた問題を読み取れる。

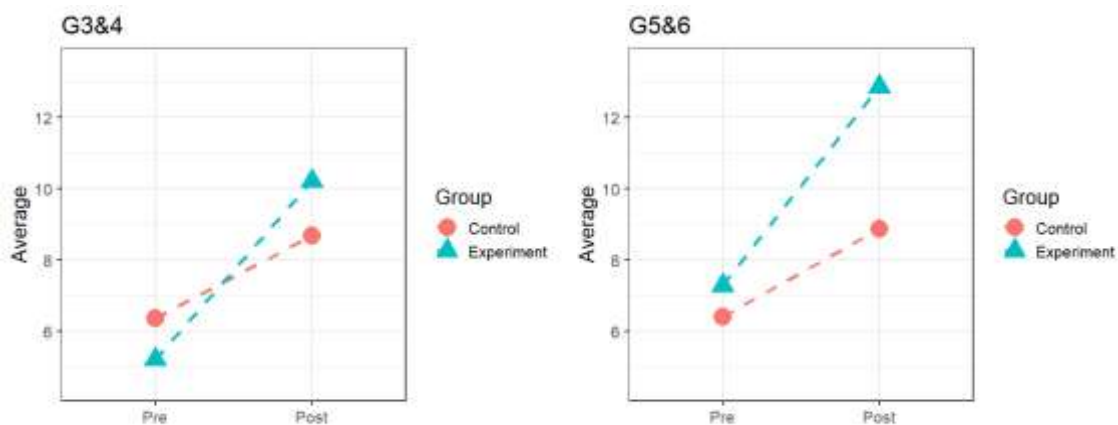
表 32 第 3・4 学年のロジスティック回帰分析の結果

問題	正答率				回帰係数				
	統制群		実験群		定数項	事後	実験群	介入効果	
	事前	事後	事前	事後					
1	17%	26%	11%	46%	0.200	1.757	0.587	4.051	*
2	27%	36%	15%	46%	0.366	1.506	0.464	3.336	*
3	23%	41%	19%	57%	0.303	2.249	0.775	2.513	*
4(1)	44%	52%	34%	64%	0.784	1.355	0.657	2.547	*
4(2)	18%	34%	18%	48%	0.215	2.399	1.022	1.753	
5(1)	19%	39%	9%	72%	0.238	2.636	0.391	10.502	*
5(2)	22%	42%	12%	68%	0.286	2.534	0.477	6.009	*
5(3)	24%	40%	13%	69%	0.320	2.083	0.446	7.307	*
6	20%	36%	14%	53%	0.253	2.174	0.616	3.257	*

7	78%	85%	72%	92%	3.605	1.572	0.696	2.729	*
8	91%	94%	88%	88%	10.000	1.567	0.733	0.609	
9(1)	93%	96%	87%	96%	14.231	1.686	0.450	2.221	
9(2)	84%	87%	74%	92%	5.387	1.189	0.515	3.263	*
12(a)	30%	47%	22%	33%	0.435	2.040	0.649	0.856	
12(b)	10%	30%	10%	19%	0.106	3.942	1.047	0.536	
12(c)	15%	40%	12%	28%	0.172	3.805	0.757	0.787	
12(d)	7%	20%	6%	23%	0.070	3.558	0.828	1.443	
13	15%	28%	10%	31%	0.172	2.210	0.648	1.787	

表 33 第5・6学年のロジスティック回帰分析の結果

問題	正答率				回帰係数				
	統制群		実験群		定数項	事後	実験群	介入効果	
	事前	事後	事前	事後					
1	34%	53%	40%	71%	0.511	2.162	1.320	1.649	
2	37%	47%	50%	79%	0.583	1.492	1.699	2.563	*
3(1)	27%	48%	30%	82%	0.377	2.450	1.130	4.396	*
3(2)	25%	49%	28%	80%	0.331	2.902	1.195	3.504	*
3(3)	23%	47%	28%	82%	0.297	2.929	1.334	3.823	*
4	23%	37%	27%	64%	0.297	1.937	1.238	2.518	*
5	3%	4%	1%	4%	0.036	1.005	0.420	3.078	
6	22%	36%	26%	68%	0.280	1.964	1.278	3.044	*
7	49%	61%	52%	82%	0.951	1.610	1.150	2.517	*
8(1)	34%	55%	28%	87%	0.511	2.343	0.774	7.258	*
8(2)	34%	50%	34%	86%	0.523	1.913	0.978	6.064	*
8(3)	27%	48%	30%	86%	0.367	2.513	1.158	5.547	*
9	20%	37%	30%	69%	0.256	2.292	1.700	2.194	*
10	73%	88%	85%	96%	2.722	2.571	2.014	1.513	
11	77%	82%	80%	83%	3.370	1.307	1.158	0.963	
12(1)	79%	91%	91%	97%	3.786	2.516	2.530	1.348	
12(2)	54%	59%	68%	72%	1.161	1.239	1.843	0.952	

第 4 章 考察

4.1 インタビュー分析に関する考察

インタビューの結果から第4学年における事前事後の伸びについて整理すると、第3・4学年においては、実験群と統制群の伸びの差は数値上、見られたことから、介入の効果はあったと言えるだろう。一方で、2.0ポイント上昇した児童もいたものの、第5・6学年になると、伸びが小さくなることが明らかになった。特に、第6学年が伸びは少ないことも判明した。このことから概念が児童にとって難解になってくると—この場合は数の範囲では小数、演算では乗法・除法—、伸びが小さくなるという傾向がある。いずれにせよ、フェーズIの成果や課題とも関連づけられる。ザンビア児童は何らかの数学的操作の理由や数学的概念そのもの、自分の数学的な考え方について言語的に説明することが難しいことが、先行研究において指摘されていた(澁谷, 2008; 2009)。第3・4学年は自然数の四則計算、第5・6学年は自然数に加えて小数においても四則演算で、初等教育段階の児童たちが言語的な説明ができるようになったことは、介入の大きな成果として捉えることができる。その一方で、小数の四則計算になると、全員一律に改善したわけではなく、個人差が見受けられたことから、計算スキルの向上についての処方箋は、それぞれで異なってくるという可能性が示唆される。また、介入ツールについても、特に、乗除に関しては他の選択肢等も今後は考えて提案していくことが必要であろう。

研究の視点からは、例えば、日本のように乗除についても多くの研究や教材が開発され実施されている。様々な視点から多様な教材の検証が必要で、それにより、多様な児童の実態が明らかになり、また、研究の蓄積もなされていく。特に乗除法の根底にある乗法的考え方は、中等教育以降の数学概念の基盤となる(図15)。その点からより充実が求められる。



図 15 乗法的考え方とその発展 (Hurst & Hurrel, 2014)

近年のアフリカの数学教育研究においては、STEM/STEAMに関する研究やモデリングに関する研究といった、先進的な研究も実施されている(Ogunniyi & Iwuanyanwu, 2024)。しかしながら、児童の計算能力や計算に伴う論理的思考力は他の数学の分野の学習においても、深く関連しているため、引き続き研究の蓄積が求められる。今後も、他の視点からの研究開発が求められる。今後は、例えば、ICTを用いた数学的活動の実施や個別最適化の学びについても実施・検討することで、スキルの習得が苦手なのか、あるいはスキルの持続性が

問題なのか、言語が問題なのか、と言った原因を明らかにして、対処法を講じる研究等も構想していけるとよい。

その他の視点としては、松尾・佐藤（2024）においては、算数と造形の総合的なプログラムの効果をザンビアと日本の幼児を対象として調査し、ザンビアの子どもたちの学びの特徴を明らかにしている。学びの連続性を踏まえて、幼児の段階で何ができていて、何が課題であるのかということ明らかにしつつ、初等教育段階における学習に連続させていくといった取り組みが多方面から実施されるとよいだろう。

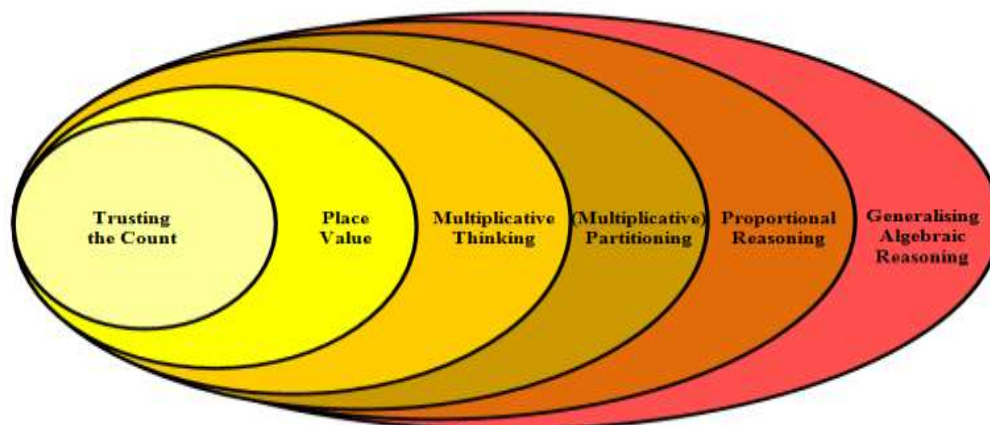
4.2. テスト分析に関する考察

テスト得点を算出し、差分の差分分析で介入効果を検討した。その結果、全体的な介入効果を確認した。そこで、ロジスティック回帰分析を用いて、出題問題ごとに介入効果を調べた。

第3・4学年では、例えば、9(1)は240と280の大きさを比べる問題であり、9(2)は350と620の大きさを比べる問題である。9(2)では介入効果が認められるが、9(1)は必ずしもそうではない。したがって、最も大きい位の大きさが等しいとき、次の位の大きさを比べる点に課題がある考えられる。10位取り記数法の構造の理解にまだまだ課題があると推察される。また、12(a)～(d)の計算問題の習得にはまだ大きな課題があると考えられる。つまり、10位取り記数法の更なる習得が今後課題と思われる。第5・6学年においても、12(1)と12(2)の小数の大きさを比べる問題に課題がみられる。個々の問題の分析から10進位取り記数法の構造の理解に課題があると思われる。

第 5 章 提言

5.1 政策に関する提言

◆ カリキュラム開発の基本的考え方

この調査を通して、エビデンスに基づく内発的アプローチ (Baba, 2022) という考えを具体化した。以下のすべてと関係するが、極端な低学力問題に対して、自国の教育課題をデータによって見つめなおす考えを指す。もちろん先行研究を全く踏まえない研究は偶然に任せられたものになってしまう恐れがある。しかし、冒頭で述べたように、ザンビアにおける極端な低学力問題は、他の国の現状とかなり異なっており、ザンビアにおける社会文化的状態を踏まえた理解をもとに、データを取り、解釈する必要がある。

比較教育学には、カリキュラム開発における Policy borrowing (Steiner-Kamisi, 2016) という考えがある。しかし、根底にある条件があまりにも異なる場合には、借用しようにもその前提条件の差異によって、それが根付かない危険性が高い。また借用のサイクルの最後に位置づくのは「現地化」であり、それは借用する政策と借用先の文脈との適合性の問題である。この報告書によって提起された内発的アプローチが今後さらに発展することを願う。

◆ カリキュラム開発における学びの組織化

ザンビアチーム、日本チームともに、フェーズ I と II において、実践的・経験的に多くのことを学んだ。それは上記の基本の考え—エビデンスに基づく内発的アプローチに基づくものである。その一つに、デザイン実験(Gravemeijer & Cobb, 2006)の手法で、繰り返しデータを取りながら評価ツールを改定して、子どもたちの持つ潜在力について知見を深めてきた。そこには、ザンビア人研究者による研究の視点が不可欠であった。それは一人の研究者というよりも、ザンビア人研究者集団のように互いに高め合うことが重要である (Baba & Nakai, 2011)。

もう一つは、カリキュラム開発局 (CDC) においても、極度の低学力の実態を明らかにして、その改善を検証する研究を行う必要があるだろう。そのような研究的要素を取り入れたカリキュラム開発を行うためにも、カリキュラム研究開発局 (CDRC) のように、「研究」の文字を入れることが、研究を通した学びの文化が機関名の中に反映される。

◆ 教師教育の改善

診断的調査で開発した評価ツール (ANNEX I-1,2) をもとに、介入ツール (ANNEX III-1,2) を作成した。その介入ツールを実験校の教員に効果的に使用してもらうことを目的として教材に関するワークショップを行った。さらに、介入時にはチームメンバーが実験校を巡回する形を取り、実施教員の指導上の疑問に答えたり、教材の特性を踏まえてアドバイスをしたりした。その結果、ザンビア的な授業であっても、子どもの理解に寄り添った介入を入れることができた教員が一定程度いることを確認することができた。

このような取り組みは、教員の教え方に変化をもたらしたり、子どもに対する気づき (湯田, 2025) を高めたりする可能性を持っている。現在、ザンビア大学における教師教育用の数学教育教科書を作成中である。ザンビア児童がタスクにこたえているインタビューデータもあり、養成教育、現職教育において非常に有効であると考えられる。

◆ 子どもの学びの改善：説明活動の重要性と可能性

一般のザンビア教員は、「児童の理解は正答を答えること」と二分法的に解釈しているだろう。しかし本調査のフェーズ I と II を通して、児童の数学的な理解にはいくつかの段階

があることが分かった。そして児童にモデルを使って数や計算を読んだり、表現させたり、言語で説明させたりすることは、数学の理解の促進につながるが見えてきた。このことは数え上げにとどまっていたザンビア児童の現状からすると可能性を提示している。

第二フェーズで取り組んだ、数の構造的理解は10進位取り記数法という数学における基本的な概念の入り口であり、発展の柱となる (Arthur, 2025)。その意味で、SACMEQ など極度の低学力が問題となってきたが、このような取り組みは、今後の発展に対して重要な意味を持っている。

◆ 言語の重要性

この調査では、図的表現、操作的表現、言語的表現、記号的表現 (中原, 1995; Lesh, Post, Behr, 1987) を意識して調査問題を作成した。上記の説明活動は、使用言語と深くかかわっていることは明白である。ザンビア大学 Bentry Nkhata シニア講師およびザンビアチームは、今回の調査において、現地語でインタビューを行う過程で、より適切で子どもに親和性がある言語的表現を模索して修正を続けた (Nkhata & Baba, 2024)。その結果、児童は聞かれている質問を的確に把握することができ、説明することができるようになってきている。

このことは回答の正誤以上に価値がある。カリキュラムにおいても、使用言語の種類だけではなく、使用言語の注目すべき点や、英語に訳しにくい部分、児童が数学を理解することに難しく感じる語彙や表現について、今後もさらに知見を深めていくべきである。

5.2 研究に関する提言

TIMSS における三層のカリキュラムに基づき、馬場 (2025) を参照しつつ考察する。

◆ エビデンスに基づく内発的カリキュラム開発

今回の調査では、数の構造的理解と乗除算の理解が課題であった。それは十進法と乗法的推論という、今日の学校数学教育において柱となるものにつながっている。調査メンバーの一人、Arthur (2025) が配列構造 (Array) を活用した取り組みを行った。その点をさらに深めると共に、カリキュラムの全般へこのアプローチを広げていく必要があるだろう。

◆ 教師教育とエビデンスの活用と分析

今回の調査では、最終段階において介入活動を行い、調査に参加教員の一部は、質の高い教育を行っていた。児童のインタビューデータ、介入活動のデータなど、教育活動にとってヒントとなるデータが多く得られた。プロジェクトメンバーや関係者、ザンビア大学の数学教育研究者とともに、現在、教師教育用の教科書やビデオの作成を行い、学校教育、教師教育への活用を目指している。

2000 年以降、Lesson study、教えるための数学的知識、Noticing など教師教育をめぐるキーワードは多数ある。上記の教科書やビデオの作成と共に、実際の活用とそれに基づく有効性の検証が課題となるだろう。

◆ 児童に関するデータの活用と分析

今回の調査では、児童の思考の様子を、分析・記録した。これまで極度の低学力は知っていたが、児童は調査の中で様々な能力を発揮した。これは間違いなく、極度の低学力を改善する上での出発点になりうる。

今回の調査では多くの関係者の理解と協力を得て、貴重なデータを集めることができた。

そのデータは共有財産であるべきである。近年のオープンサイエンス、オープンデータの動向は、再現性など研究の信頼性を担保する方向性と、有用性など現地の研究者や市民が活用できることである。そのために、研究対象者と研究者との対等な関係にも触れている。データが取れるからということ、未知の世界に飛び込みデータを取ればよいわけではなく、データのとる意味を理解してもらうこと、そしてデータから得られる情報を還元していくことなど、研究活動の基本的な姿勢に関わることである。そのような取り組みを実装していくことは、調査に関わる我々が意識していくべきことである。

◆ 専門家集団の形成

最後にこのような研究全体を推進していくうえで、専門家集団の形成が不可欠である(Baba & Nakai, 2011)。そのためには研究上の倫理的配慮、開発途上国の社会文化的側面に配慮した研究の知識などを専門家と共に形成していくことが求められる。

参考文献

- Arthur, M. (2025). The Use of Array Patterns to Enhance Primary School Pupils' Multiplicative Thinking in Zambia. Unpublished Doctoral Dissertation. Hiroshima University.
- Baba, T. & Nkhata, B. "Evidence-Based and Endogenous Curriculum Development Through a Research Project in Zambia". in Ui Hock Cheah, Masami Isoda, Arne Jakobsen (eds) Exploring International Cooperation in Mathematics Education: An Analysis of Issues Affordances, and Constraints (in press).
- 馬場卓也 (2025)「アフリカにおける数学教育研究の過去、現在、未来」『アフリカ教育研究』第 16 号、3-20 頁。
- Baba, T. (2022, February 12). Evidence-based and Endogenous Curriculum Development [Invited lecture]. International Cooperation Development in Mathematics Education, University of Tsukuba, Japan.
- Baba, T., Nakawa, N., Nkhata, B., Arthur, M., Barbara, M., Chikola, D., Emmanuel, K., Nambwe, B., Kosaka, M., Kusaka, S., Minakoshi, K., Spiwe, T., Takuzwa J.N., & Watanabe, K. (2021). Project Research for "Analysis of Challenges and Solutions for Improving Numeracy Competence in Zambia" Project Completion Report November 2021 Japan International Cooperation Agency Hiroshima University.
- Baba, T., Nakawa, N., Nkhata, B., Arther, M., Barbara, M., Emmanuel, K., Kosaka, M., Kusaka, S., Mambwe, B., Nkhalamo, C.J., Watanabe, K. (2019). The Development of an Assessment Instrument for Numeracy Competence and its Application to Selected Primary Schools in Zambia. Zambia Journal of Teacher Professional Growth (ZJTPG), 5(2), 72-92. The University of Zambia Press.
- Baba, T., & Nakai, K. (2011). Teachers' institution and participation in a lesson study project in Zambia: Implication and possibilities. In Proceedings of seminars held at the Center for the Study of International Cooperation in Education (CICE), Africa-Asia university dialogue for educational development: Report of the International Experience Sharing Seminar (2); Actual status and issues of teacher professional development (pp. 85-102). Hiroshima, Japan: Hiroshima University.
- Gravemeijer, K. & Cobb, P. (2006) Design research from a learning design perspective. In Van den Akker, J., Gravemeijer, K., McKenney, S., & Nieveen, N. (Eds.). Educational Design Research (1st ed.). Routledge. (pp. 17-51)
<https://doi.org/10.4324/9780203088364>
- Hungi, N., Makuwa, D., Ross, K., Saito, M., Dolata, S., Cappelle, F. V. (2010). SACMEQIII Project Result: Pupil Achievement Levels in Reading and Mathematics. Working Document Number 1. Paris: SACMEQ
- Hurst, C. & Hurrell, D. (2014). Developing the Big Ideas of Number. International Journal of Educational Studies in Mathematics. 1. 1-18. 10.17278/ijesim.2014.02.001.
- Hurst, C. & Hurrell, D. (2016). Investigating Children's Multiplicative Thinking: Implications for Teaching. European Journal of STEM Education. 1. 1-11.

- 10.20897/lectito.201656.
- JICA & Hiroshima University (2021). Project Research for “Analysis of Challenges and Solutions for Improving Numeracy Competence in Zambia” Project Completion Report. <https://openjicareport.jica.go.jp/pdf/12362984.pdf>
- Lesh R., Post, T. & Behr, M. (1987). Representations and translations among representations in mathematics learning and problem solving. In C. Janvier (Ed.), *Problems of Representation in the Teaching and Learning of Mathematics* (pp. 33-40) Hillsdale, NJ: Lawrence Erlbaum Associates.
- 松尾七重・佐藤 真帆(2024). 算数と造形の総合的なプログラムの効果 日本とザンビアの場合『日本科学教育学会年会論文集』248 (1) https://doi.org/10.14935/jssep.48.0_449
- MoGE (Ministry of General Education, Zambia) (2017). *Zambia’s National Assessment Survey Report 2016: Learning Achievement at the Primary School Level*. MoGE.
- 中原忠男(1995)『算数数学教育における構成的アプローチの研究』聖文社.
- Nakawa, N. (2016) Children's Recognition of Numbers in the Republic of Zambia: Focusing on Subitising and Counting toward Concrete and Semi-Concrete Objects, 7, 155-172. *Africa Education Research Journal*, 7, 155-172.
- 中和渚(2012)「ザンビア共和国の数学教育開発のための基礎的調査(2)－中央州カブウェのある基礎学校における子どもたちの1桁の乗法の習熟度と課題－」. 第45回日本数学教育学会研究発表会発表資料. 2012年11月12日.
- Nkhata, B., Baba, T. (2024). The Influence of Non-Mathematical Impediments on Development of Diagnostic Tools in Numeracy Competence Project in Zambia. ICME 15th Congress on Mathematical Education. July7-14, 2024, ICC, Sydney, Australia.
- OECD (2019), *PISA 2018 Results (Volume I): What Students Know and Can Do*, PISA, OECD Publishing, Paris, <https://doi.org/10.1787/5f07c754-en>.
- 小川啓一、江連誠、武寛子(2005)『万人のための教育(EFA)への挑戦：日本のODAに対する提言』.国際協力機構国際協力総合研修所.
- Ogunniyi, M., & Iwuanyanwu, P. N. (2024). Analysis of teachers’ perspectives towards the use of IKS to improve STEM education for sustainable development. *African Journal of Research in Mathematics, Science and Technology Education*, 28(3), 319-329. <https://doi.org/10.1080/18117295.2024.2352980>
- 澁谷渚 (2009)「本質的学習環境 (SLE) に基づく数学科授業開発研究 (2)－ザンビアのある基礎学校における生徒の数のパターンの認識に関する記述の分析」『数学教育学研究』, 15(1), 136-146.
- 澁谷渚 (2008)「本質的学習環境 (SLE) に基づく数学科授業開発研究 (1)－ザンビア基礎学校における生徒の活動の分析－」『数学教育学研究』, 14, 187-197.
- Simon, M. A. (1995). Investigating the Development of Multiplicative Reasoning [Review of *The Development of Multiplicative Reasoning in the Learning of Mathematics*, by G. Harel & J. Confrey]. *Journal for Research in Mathematics Education*, 26(3), 282-288. <https://doi.org/10.2307/749132>

- Steiner-Khamsi, G. (2016). New directions in policy borrowing research. *Asia Pacific Education Review*, 17. 381-390. <https://doi.org/10.1007/s12564-016-9442-9>
- Uchida, T. (2009). The diagnostic evaluation of pupils' performance in basic school in Zambia: Focusing on discrimination of performance and educational suggestiveness. *Journal of International Cooperation in Education*, 12(2), 1-12.
- Vergnaud, G. (2009). The Theory of Conceptual Fields. *Human Development* 52(2). 83-94. <https://doi.org/10.1159/000202727>
- Vergnaud, G. (1983). Multiplicative structures, in Lesh, R. and Landau, M. (Eds), *Acquisition of Mathematics Concepts and Processes*, Academic Press. 127-174.
- World Bank (2022) *The State of Global Learning Poverty: 2022 Update*. <https://thedocs.worldbank.org/en/doc/e52f55322528903b27f1b7e61238e416-0200022022/original/Learning-poverty-report-2022-06-21-final-V7-0-conferenceEdition.pdf>
- 湯澤 正通, ワーキングメモリの発達と児童生徒の学習: 読み書き・算数障害への支援, 発達心理学研究, 2019, 30 巻, 4 号, p. 188-201. <https://doi.org/10.11201/jjdp.30.188>, https://www.jstage.jst.go.jp/article/jjdp/30/4/30_188/_article/-char/ja
- 湯田しおり (2025) 『ザンビアにおける数学教師の気づきに関する研究』、広島大学大学院修士論文(未公刊).

Annex

Assessment tool on natural numbers

[More than 100]

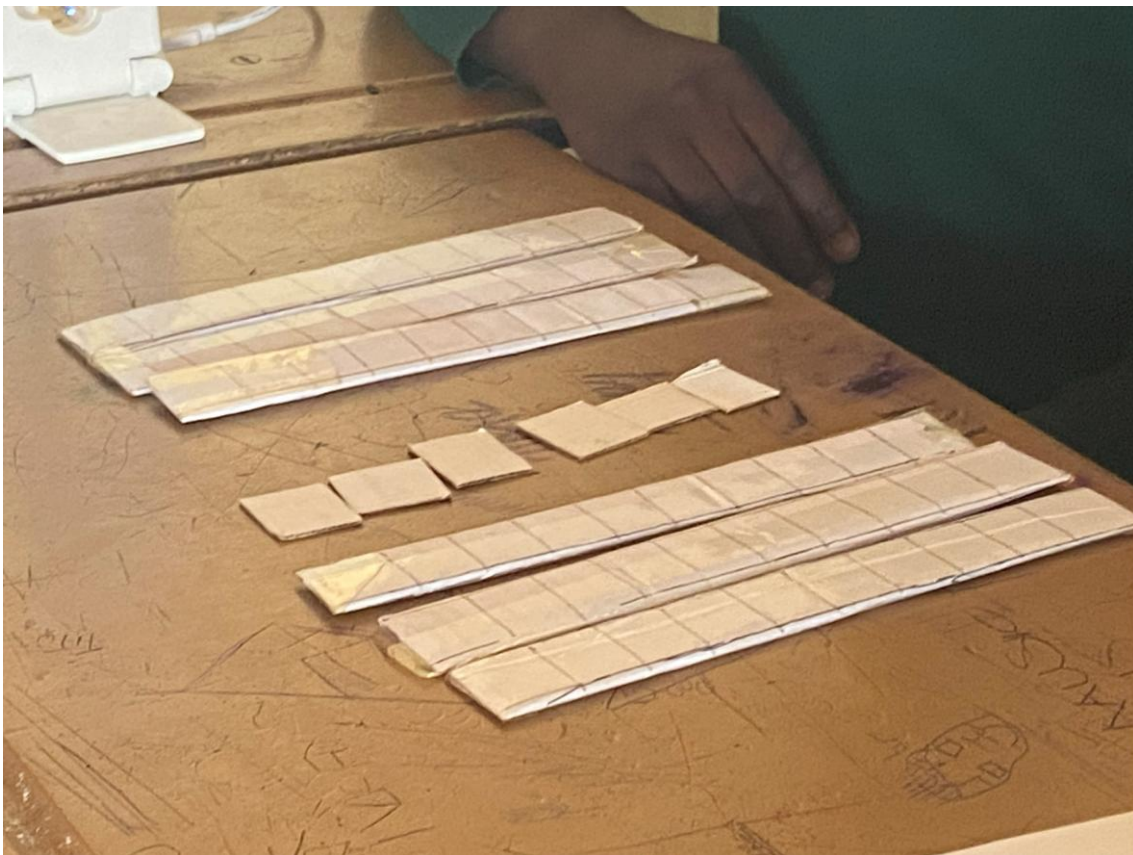

March 2025

Preliminary test

Task 1

[4.1 Seeing numbers in terms of unit and relative size of numbers]

Prepares five frames of 10 vertically.
 Interviewer fills 49 bottle tops.
 Q. 'How many bottle tops are there?'

Local language
 Tuli tungati tu pendelo utu?
 Wapeza bwanji ansa?
 (If pupil says 'napenda', follow up with,
 'wapenda bwanji?')

How many?

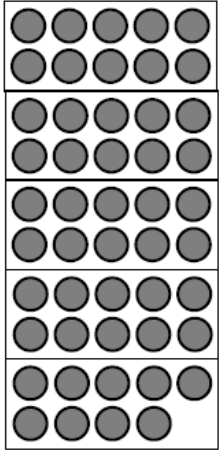

Task 2

[5.3b Understanding decimal system]

Q. "Indicate the number (76) on the number line"

Local language
 Ni ikile ka dot pa namba line pamene pa funika ku nkhalala 76.
 Wazibwanji kuti ndiye pamene ifunika ku nkhalala apa

5-3 (b) Number line (2)

[Note]

- Focus on meaning of numbers and operations using representation such as number lines, grids/boxes, tiles.
- Focus on hierarchical structure of numbers.
- Try some items including translation between different representations.
- Neither big numbers such as 700s, 800s nor numbers with digit “0” to avoid confusion.
- No carrying nor borrowing in operation.

1.1

(1) Pointing at 0, ask what number is this. Then, pointing at 100, what number is this? What does each small line represent?

(2) Count the marked places on each of the number line up to 300.

Local language:

(1) Ni namba bwanji iyi? Kamu line kamoozi katantauza chani?

(2) Penda tuma line pa namba line iyi kufika pa 300.

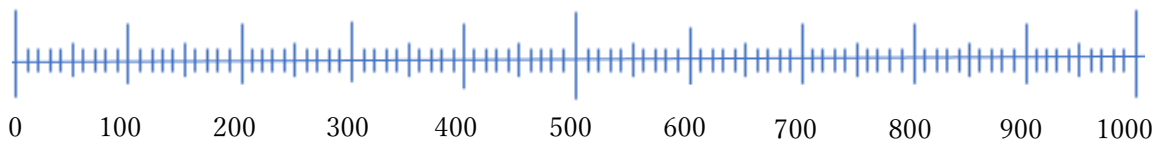

Level 1 Neither of them is correct.

Level 2 Only former (1) or latter (2) is correct.

Level 3 Both former and latter are correct. (A pupil/ interviewer asks some questions.)

Level 4 Both former and latter are correct smoothly.

Level 5 Both former and latter are correct smoothly with explanation.

[Objective] To be able to count the numbers along the number line by recognizing numbers whether there are marks or not and their equidistance.

[Support materials] Large number line

[Upon difficulties] Point out marks one by one and ask them to read.

1.2

Indicate with an arrow where the number 260 should be on each of these number lines. How did you know?

Local language: Ika ka arrow pa ma namba line aya pamene pa funika ku nkhalo 260. Waziba bwanji?

(1)

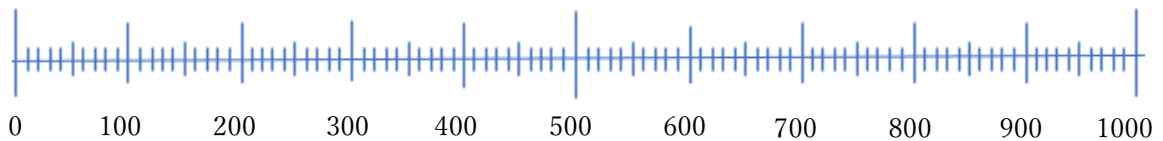

(2)

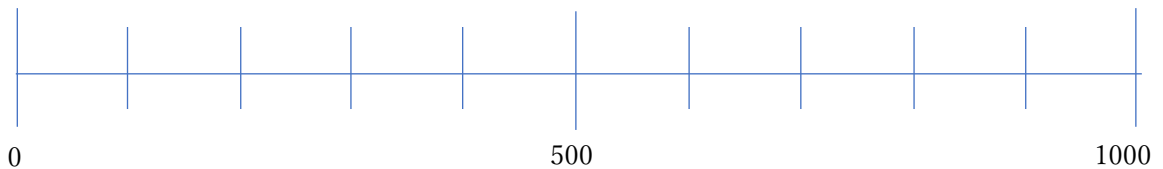

.....

Level 1 Neither of them is correct.

Level 2 Only former (1) or latter (2) is correct.

Level 3 Both former and latter are correct. (A pupil/ interviewer asks some questions.)

Level 4 Both former and latter are correct smoothly.

Level 5 Both former and latter are correct smoothly with explanation.

[Objective] To be able to locate the number along the number line whether there are marks or not.

[Support materials] Large number line

[Upon difficulties]

(1) Let the pupils count along the number line.

(2) Ask them where the point lies approximately.

(3) Remind them of correspondence between two number lines.

1.3

What number does the marked arrow represent on the number line? How did you know?

Write the number.

Local language: Apa pali ka arrow ni namba bwanji? Waziba bwanji? Lemba namba.

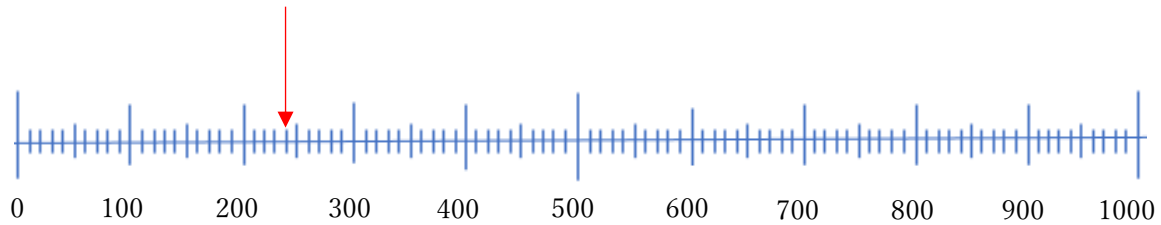

Level 1 Not at all

Level 2 The answer is between 230 and 250.

Level 3 The answer is exactly 240 (A pupil/ interviewer asks some questions.)

Level 4 The answer is exactly 240 smoothly.

Level 5 The answer is exactly 240 smoothly with explanation.

[Objective] To be able to read the number located along the number line.

[Support materials] Large number line

[Upon difficulties]

(1) Let the pupils count along the number line.

(2) The answer can be 240, 245.

1.4

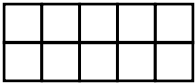
(1) If  represents 100, what number does the circled grids/ boxes represent?
Write down the number.

Local language: Ngati ka grid aka katantauza 100, tuma grid/box twamene ta sekocling'a tutantauza namba bbwanji? Lemba namba.

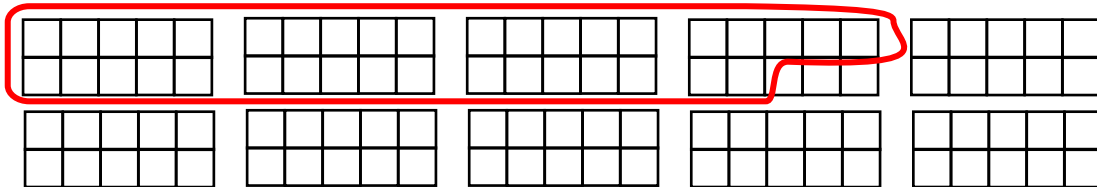

(2) Mark the above number on the number line with an arrow. Explain how the circled grid and number line relate to each other.

Local language: Onesa iyi namba naka arrow pa namba line iyi. Number 1 na number 2, vipalana bwanji?

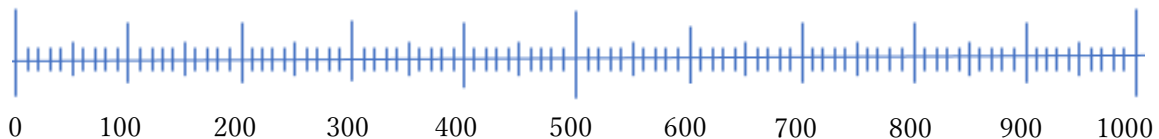

Level 1 Neither of them is correct.

Level 2 Only former (1) or latter (2) is correct.

Level 3 Both former and latter are correct. (A pupil/ interviewer asks some questions.)

Level 4 Both former and latter are correct smoothly.

Level 5 Both former and latter are correct smoothly with explanation.

Note: It is desirable to be able to relate both former and latter.

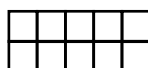

[Objective] To be able to read the number represented in the boxes and show it along the number line.

[Support materials] Large number line, ten-frames

[Upon difficulties]

(1) Count big boxes one by one (100, 200, 300, ...).

1.5

(1) If  represents 100, circle 260 using the grids/boxes. Explain the reason.

Local language: Ngati aka ka grid katantauza 100, sekoling'a 260 kusebenzesa tuma grid/box utu.

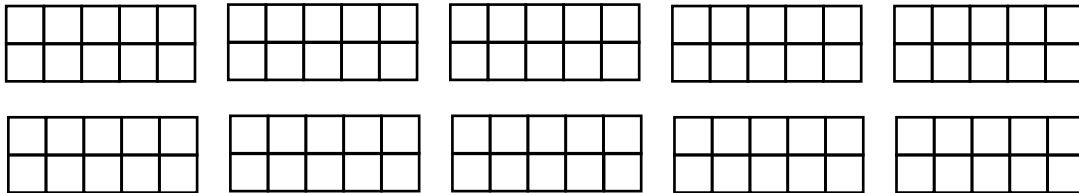

(2) If  represents 100, circle 260 using the grids/boxes. Explain the reason.

Local language: Ngati aka ka grid katantauza 100, sekoling'a 260 kusebenzesa tuma grid/box utu.

Waziba bwanji?



Level 1 Neither of them is correct.

Level 2 Only (1) is correct. (Only one large circle is accepted as appropriate. Counting with small circles or dots is as pre-mature.)

Level 3 Both former and latter are correct. (A pupil/ interviewer asks some questions.)

Level 4 Both former and latter are correct smoothly.

Level 5 Both former and latter are correct smoothly with explanation.

[Objective] To be able to circle the number in the grids whether there are dividing lines or not.

[Support materials] Ten-frames

[Upon difficulties]

(1) Let the pupils count small boxes one by one. From left above to right above and then left down to right down.

(2) Showing the ten-frames front and back side so that each box is the same whether there are dividing lines or not.

(3) Change the number to easy one (e.g., 50).

2.1

Arrange the numbers [400, 80, 210] in order from smallest to biggest. Explain the reason for your answer.

Local language: Tantika ma namba aya [400, 80, 210] kuyambila naing'ono kusilizisa naikulu.

Waziba bwanji kuti nimwamene yafunika kunkalila?

Level 1 cannot say the answer or say something meaningless not indicated in the question.

Level 2 the arranged numbers are incorrect.

Level 3 the arranged numbers are correct. (A pupil/ interviewer asks some questions.)

Level 4 the arranged numbers are correct smoothly.

Level 5 the arranged numbers are correct smoothly with explanation.

[Objective] To be able to compare the size of two numbers using numerals.

[Introduction of tiles]

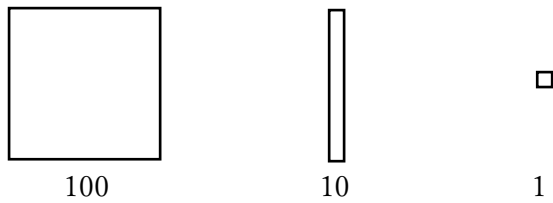

Show 1 tile. This is 1 tile.

Show 10 tile and ask what tile it is. Why?

Show 100 tile and ask what tile it is. Why?

2.2

Show the numbers 342 and 350 using tiles.

- (1) Say which is bigger?
- (2) Explain the reason using tiles.

Local language: Onesa ma namba 342 na 350 kusebenzesa ma tiles. Kamba niyiti ikhulu? Ni uze mwamene wazibila kusebenzesa ma tiles.

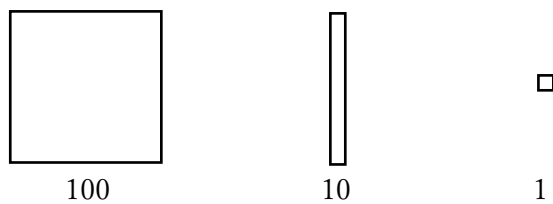

Level 1 cannot say the answer.

Level 2 the represented numbers are incorrect.

Level 3 the represented numbers are correct. (A pupil/ interviewer asks some questions.)

Level 4 the represented numbers are correct smoothly.

Level 5 the represented numbers are correct smoothly with explanation.

[Objective] To be able to compare the size of two numbers using.

2.3

(1) On the number line, show the numbers [50, 370, 160] with arrows.

Local language:

Kusebenzesa tuma arrow, langiza ma namba aya [50, 370, 160] pa namba line.

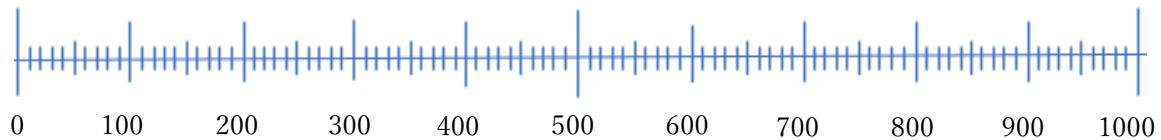

(2) Which arrow represents the smallest number and the biggest number? Explain the reason for your answer using Number line.

Local language: Kamba nikati ka arrow kamene kalangiza namba ing'ono na ikhulu? Ni uze mwamene wazibila kusebenzesa namba line.

Level 1 cannot say the answer or say something meaningless not indicated in the question.

Level 2 the represented numbers on the number line are incorrect.

Level 3 the represented numbers on the number line are correct. (A pupil/ interviewer asks some questions.)

Level 4 the represented numbers on the number line are correct smoothly.

Level 5 the represented numbers on the number line are correct smoothly with explanation.

[Objective] To be able to compare the size of two numbers using.

3a**(1) Do the following calculation. 330**

Local language: Peza

$$\begin{array}{r} 330 \\ + 135 \\ \hline \end{array}$$

(2) Place 330 using tiles. Show me 330+135 using tiles.

Local language: Niyikile 330 kusebenzesa ma tiles. Ni onese 330 + 135 kusebenzesa ma tiles.

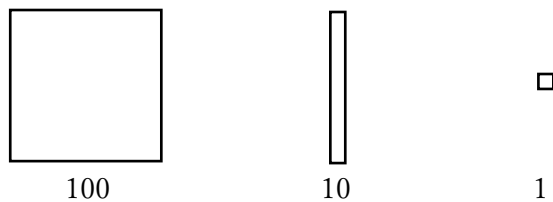
**(3) Then, explain the reason.**

Local language: Waziba bwanji.

Level 1 Neither of them is correct.

Level 2 Only (1) is correct.

Level 3 Both (1) and (2) are correct. (A pupil/ interviewer asks some questions.)

Level 4 Both (1) and (2) are correct smoothly or (2) and (3) are correct smoothly.

Level 5 Both (1) and (2) are correct smoothly with explanation (3).

[Objective] To be able to understand the meaning of addition and express it using tiles and correspond tiles operation and calculation in column.

3s

(1) Do the following calculation. 385

Local language: Peza $\underline{\quad - 152}$

(2) Place 385 using tiles. Show me $385 - 152$ using tiles.

Local language: Niyikile 385 kusebenzesa ma tiles. Ni onese $385 - 152$ kusebenzesa ma tiles.

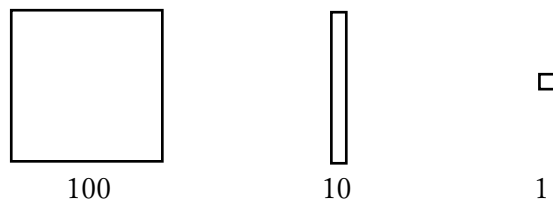

(3) Then, explain the reason.

Local language: Waziba bwanji.

Level 1 Neither of them is correct.

Level 2 Only (1) is correct.

Level 3 Both (1) and (2) are correct. (A pupil/ interviewer asks some questions.

Level 4 Both (1) and (2) are correct smoothly or (2) and (3) are correct smoothly.

Level 5 Both (1) and (2) are correct smoothly with explanation (3).

[Objective] To be able to understand the meaning of subtraction and express it using tiles and correspond tiles operation and calculation in column.

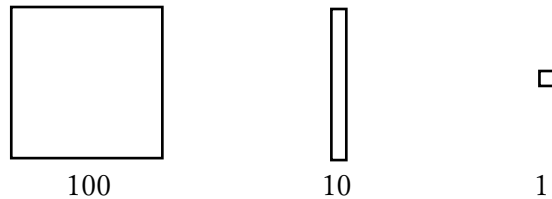
3m**(1) Do the following calculation. 240**Local language: Peza $\underline{\times 3}$ **(2) Place 240 using tiles. Show me 3×240 using tiles.**Local language: Niyikile 240 kusebenzesa ma tiles. Ni onese 3×240 kusebenzesa ma tiles.**(3) Then, explain the reason.**

Local language: Waziba bwanji.

Level 1 Neither of them is correct.

Level 2 Only (1) is correct.

Level 3 Both (1) and (2) are correct. . (A pupil/ interviewer asks some questions.)

Level 4 Both (1) and (2) are correct smoothly or (2) and (3) are correct smoothly.

Level 5 Both (1) and (2) are correct smoothly with explanation (3).

[Objective] To be able to understand the meaning of multiplication and express it using tiles and correspond tiles operation and calculation in column.

3d**(1) Do the following calculation. $\overline{3}360$**

Local language: Peza

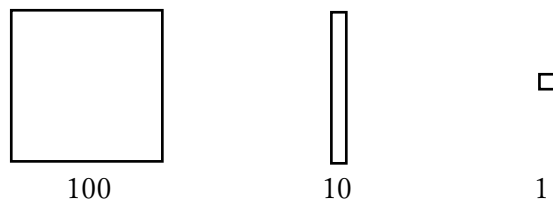
(2) Place 360 using tiles. Show me $360 \div 3$ using tiles.Local language: Niyikile 360 kusebenzesa ma tiles. Ni onese $360 \div 3$ kusebenzesa ma tiles.**(3) Then, explain the reason.**

Local language: Waziba bwanji.

Level 1 Neither of them is correct.

Level 2 Only (1) is correct.

Level 3 Both (1) and (2) are correct. . (A pupil/ interviewer asks some questions.

Level 4 Both (1) and (2) are correct smoothly or (2) and (3) are correct smoothly.

Level 5 Both (1) and (2) are correct smoothly with explanation (3).

[Objective] To be able to understand the meaning of division and express it using tiles and correspond tiles operation and calculation in column.

**Assessment tool on decimal
numbers
[First decimal places]**

[Note]

- Focus on meaning of numbers and operations using representation such as number line, grids, tiles.
- Focus on hierarchical structure of numbers.
- Try some items including translation between different representations.
- Neither small numbers such as second decimal places (0.01s) nor numbers with digit “0” to avoid confusion
- No carrying nor borrowing in operation.

1.1

(1) Pointing at 0, ask what number is this. Then, pointing at 1.0 what number is this?

(2) What number does the marked arrow represent on the number line? How did you know?

Write the number.

Local language:

(1) Ni namba bwanji iyi? Belenga ma namba ali pa namba line iyi.

(2) Apa pali ka arrow ni namba bwanji? Waziba bwanji? Lemba namba.

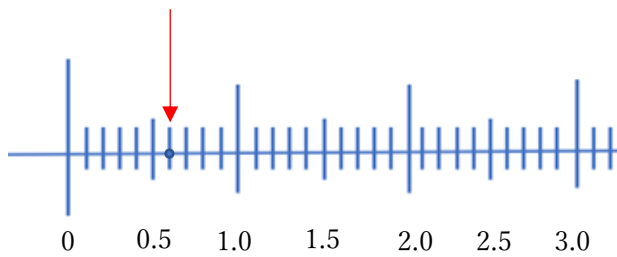

Level 1 Not at all

Level 2 Only (1) is correct.

Level 3 The answer is exactly 0.6. (A pupil/ interviewer asks some questions.)

Level 4 The answer is exactly 0.6 smoothly.

Level 5 The answer is exactly 0.6 smoothly with explanation.

1.2

(1) What does each small line represent?

(2) Count the marked places on the number line below up to 3.0.

Local language:

(1) Ka mu line kamoozi katantauza chani pa namba line iyi?

(2) Penda tuma line pa namba line iyi kufika pa 3.0.

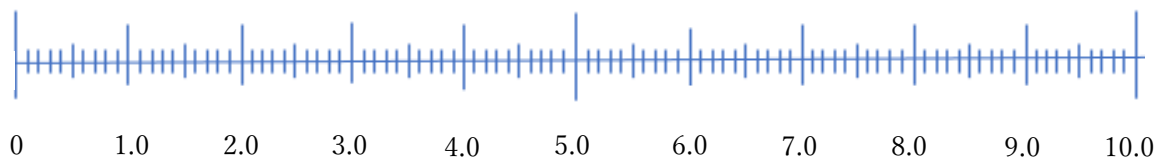

Level 1 Neither of them is correct.

Level 2 Only former (1) or latter (2) is correct.

Level 3 Both former and latter are correct. (A pupil/ interviewer asks some questions.)

Level 4 Both former and latter are correct smoothly.

Level 5 Both former and latter are correct smoothly with explanation.

1.3

Indicate with an arrow where the number 2.6 should be on each of these number lines. How did you know?

Local language: Ika ka arrow pa ma namba line aya pamene pa funika ku nkhalala 2.6. Waziba bwanji?

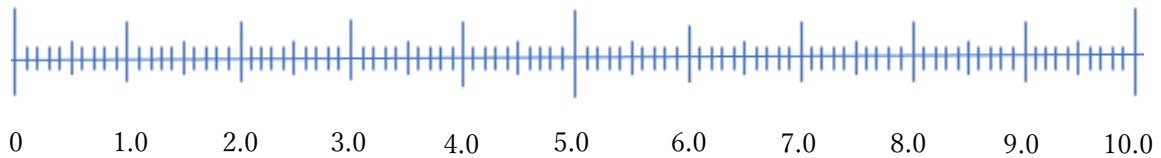

(2)

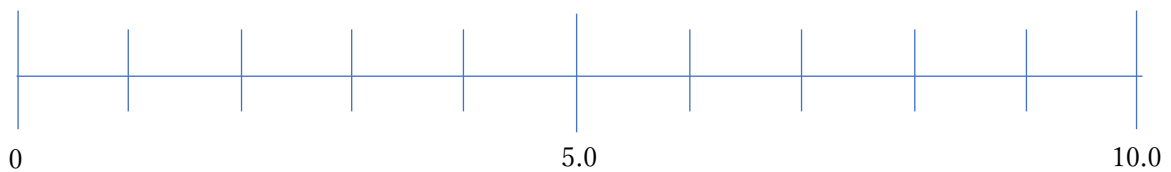

Level 1 Neither of them is correct.

Level 2 Only former (1) or latter (2) is correct.

Level 3 Both former and latter are correct. (A pupil/ interviewer asks some questions.)

Level 4 Both former and latter are correct smoothly.

Level 5 Both former and latter are correct smoothly with explanation.

[Objective] To be able to locate the number along the number line whether there are marks or not.

[Support materials] Large number line

[Upon difficulties]

(1) Let the pupils count along the number line.

(2) Ask them where the point lies approximately.

(3) Remind them of correspondence between two number lines.

1.4

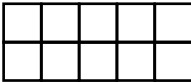
(1) If  represents 1, what number does the circled grids/ boxes represent?
Write down the number.

Local language: Ngati ka grid aka katantauza 1, tuma grid/box twamene ta sekocling'a tutantauza namba bbwanji? Lemba namba.

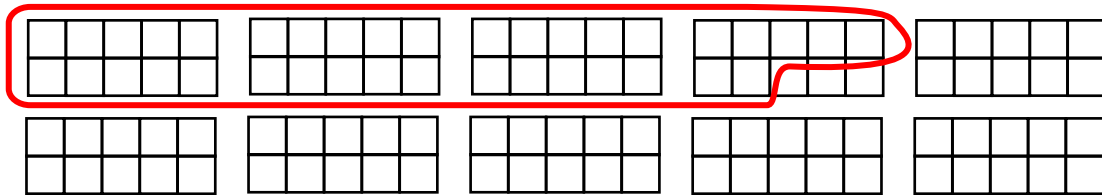

(2) Mark the above number on the number line with an arrow. Explain their relation using Grids/ boxes and Number line.

Local language: Onesa iyi namba naka arrow pa namba line iyi. Number 1 na number 2, vipalana bwanji?

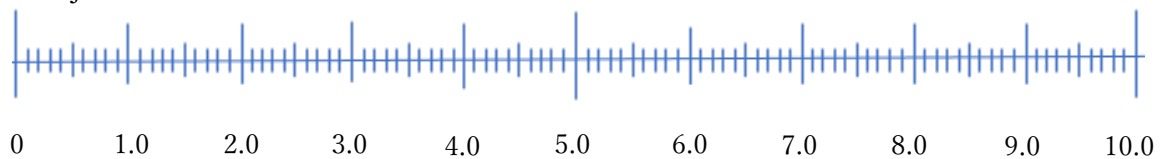

Level 1 Neither of them is correct.

Level 2 Only former (1) or latter (2) is correct.

Level 3 Both former and latter are correct. (A pupil/ interviewer asks some questions.)

Level 4 Both former and latter are correct smoothly.

Level 5 Relate both former and latter smoothly with explanation.

Note: It is desirable to be able to relate both former and latter.

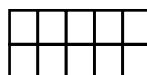

[Objective] To be able to read the number represented in the boxes and show it along the number line.

[Support materials] Large number line, ten-frames

[Upon difficulties]

(1) Count big boxes one by one (1, 2, 3, ...).

1.5

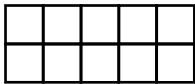
(1) If  represents 1, circle 2.6 using the grids/boxes. Explain the reason.

Local language: Ngati aka ka grid katantauza 1, sekoling'a 2.6 kusebenzesa tuma grid/box utu. Waziba bwanji?

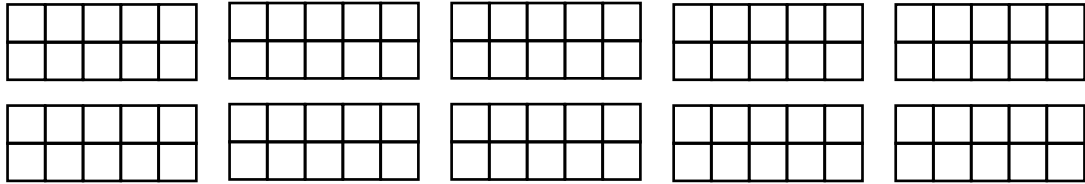

(2) If  represents 1, circle 2.6 using the grids/boxes. Explain the reason.

Local language: Ngati aka ka grid katantauza 1, sekoling'a 2.6 kusebenzesa tuma grid/box utu. Waziba bwanji?

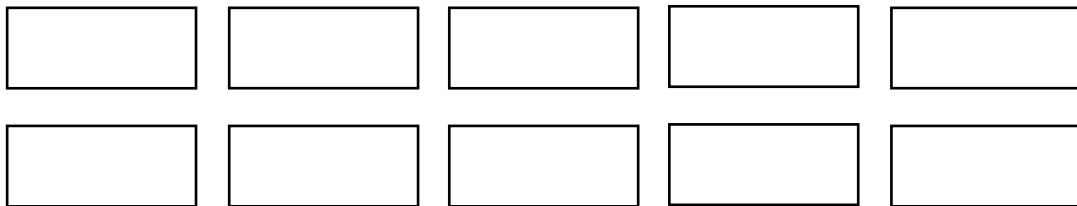

Level 1 Neither of them is correct.

Level 2 Only (1) is correct. (Only one large circle is accepted as appropriate. Counting with small circles or dots is as pre-mature.)

Level 3 Both former and latter are correct. (A pupil/ interviewer asks some questions.)

Level 4 Both former and latter are correct smoothly.

Level 5 Both former and latter are correct smoothly with explanation.

[Objective] To be able to circle the number in the boxes whether there are dividing lines or not.

[Support materials] Ten-frames

[Upon difficulties]

(1) Let the pupils count small boxes one by one. From left above to right above and then left down to right down.

(2) Showing the ten-frames front and back side so that each box is the same whether there are dividing lines or not.

(3) Change the number to easy one (e.g., 0.5)

2.1

Arrange the numbers [1.2, 0.8, 2.1] in order from smallest to biggest. Explain the reason for your answer.

Local language: Tantika ma namba aya [1.2, 0.8, 2.1] kuyambila naying'ono kusilizisa naikulu. Waziba bwanji kuti nimwanene yafunika kunkalila?

Level 1 cannot say the answer or say something meaningless not indicated in the question.

Level 2 the arranged numbers are incorrect.

Level 3 the arranged numbers are correct. (A pupil/ interviewer asks some questions.)

Level 4 the arranged numbers are correct smoothly.

Level 5 the arranged numbers are correct smoothly with explanation.

[Objective] To be able to compare the size of two numbers using numerals.

[Introduction of tiles]

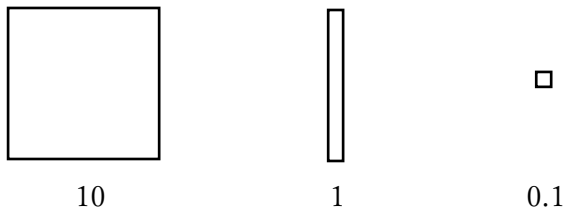

Show 0.1 tile. This is 0.1 tile.

Show 1 tile and ask what tile it is. Why?

Show 10 tile and ask what tile it is. Why?

2.2

Please show the numbers 3.5 and 1.6 using tiles.

(1) Say which is bigger?

(2) Explain the reason using tiles.

Local language: Nionese 3.5 na 1.6 kusebenzesa ma tiles. Kamba niyiti ikhulu. Ni uze mwamene wazibila kusebenzesa ma tiles.

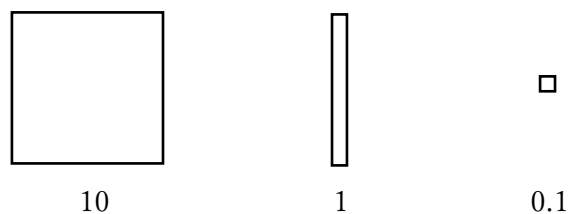

Level 1 cannot say the answer.

Level 2 the represented numbers are incorrect.

Level 3 the represented numbers are correct. (A pupil/ interviewer asks some questions.)

Level 4 the represented numbers are correct smoothly.

Level 5 the represented numbers are correct smoothly with explanation.

[Objective] To be able to compare the size of two numbers using tiles.

2.3

(1) On the number line, show the numbers [1.6, 3.7, 0.5] with arrows.

Local language:

Local language: Kusebenzesa tuma arrow, onesa ma namba aya [1.6, 3.7, 0.5] pa namba line.

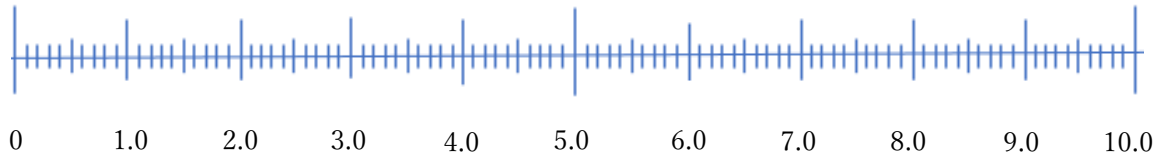

(2) Which arrow represents the smallest number and the biggest number? Explain the reason for your answer using the number line.

Local language: Kamba nikati ka arrow kamene kasonta pa namba ingono na ikhulu? Ni uze mwamene wazibila kusebenzesa namba line.

Level 1 cannot say the answer or say something meaningless not indicated in the question.

Level 2 the numbers on the number line are incorrect.

Level 3 the numbers on the number line are correct. (A pupil/ interviewer asks some questions.)

Level 4 the numbers on the number line are correct smoothly.

Level 5 the numbers on the number line are correct smoothly with explanation.

[Objective] To be able to compare the size of two numbers using number lines.

3a

(1) Do the following calculation. 33.1

Local language: Peza +13.5

(2) Place 33.1 using tiles. Show me 33.1+13.5 using tiles.

Local language: Niyikile 33.1 kusebenzesa ma tiles. Ni onese 33.1 + 13.5 kusebenzesa ma tiles.

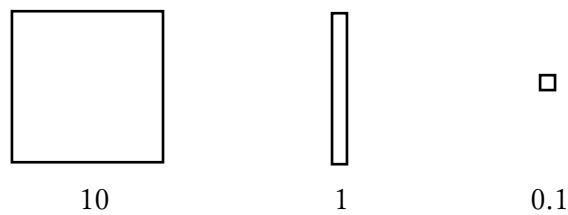

(3) Then, explain the reason.

Local language: Ni uze mwamene wazibila.

Level 1 Neither of them is correct.

Level 2 Only (1) is correct.

Level 3 Both (1) and (2) are correct (A pupil/ interviewer asks some questions.)

Level 4 Both (1) and (2) are correct smoothly or (2) and (3) are correct smoothly.

Level 5 Both (1) and (2) are correct smoothly with explanation (3).

[Objective] To be able to understand the meaning of addition and express it using tiles and correspond tiles operation and calculation in column.

3s

(1) Do the following calculation. 3.5

-1.5

Local language: Peza

(2) Place 3.5 using tiles. Show me $3.5 - 1.5$ using tiles.

Local language: Niyikile 3.5 kusebenzesa ma tiles. Ni onese $3.5 - 1.5$ kusebenzesa ma tiles.

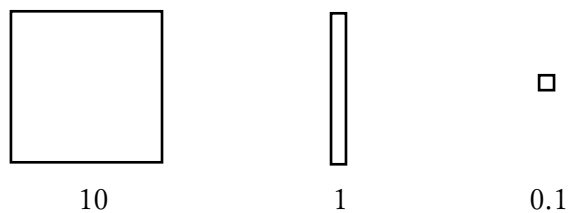

(3) Then, explain the reason.

Local language: Waziba bwanji.

Level 1 Neither of them is correct.

Level 2 Only (1) is correct.

Level 3 Both (1) and (2) are correct. (A pupil/ interviewer asks some questions.)

Level 4 Both (1) and (2) are correct smoothly or (2) and (3) are correct smoothly.

Level 5 Both (1) and (2) are correct smoothly with explanation (3).

[Objective] To be able to understand the meaning of subtraction and express it using tiles and correspond tiles operation and calculation in column.

3m

(1) Do the following calculation.

$$\begin{array}{r} 2.4 \\ \times 3 \\ \hline \end{array}$$

Local language: Peza

(2) Place 2.4 using tiles. Show me 3×2.4 using tiles.

Local language: Niyikile 2.4 kusebenzesa ma tiles. Ni onese 3×2.4 kusebenzesa ma tiles.

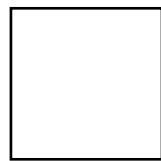

10

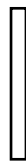

1



0.1

(3) Then, explain the reason.

Local language: Waziba bwanji.

Level 1 Neither of them is correct.

Level 2 Only (1) is correct.

Level 3 Both (1) and (2) are correct. (A pupil/ interviewer asks some questions.)

Level 4 Both (1) and (2) are correct smoothly or (2) and (3) are correct smoothly.

Level 5 Both (1) and (2) are correct smoothly with explanation (3).

[Objective] To be able to understand the meaning of multiplication and express it using tiles and correspond tiles operation and calculation in column.

3d

(1) Do the following calculation. $3\overline{)3.6}$

Local language: Peza

(2) Place 3.6 using tiles. Show me $3.6 \div 3$ using tiles.

Local language: Niyikile 3.6 kusebenzesa ma tiles. Ni onese $3.6 \div 3$ kusebezesa ma tiles.

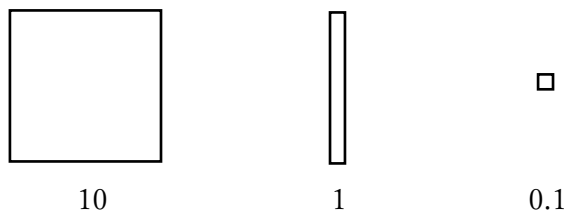

(3) Then, explain the reason.

Local language: Waziba bwanji.

-
- Level 1 Neither of them is correct.
 - Level 2 Only (1) is correct.
 - Level 3 Both (1) and (2) are correct. (A pupil/ interviewer asks some questions.)
 - Level 4 Both (1) and (2) are correct smoothly or (2) and (3) are correct.
 - Level 5 Both (1) and (2) are correct smoothly with explanation (3).

[Objective] To be able to understand the meaning of division and express it using tiles and correspond tiles operation and calculation in column.

Interview Record

Date: _____ Interviewer's name: _____

School: _____ Student's name: _____ Grade & Class: _____

【Natural number】

Task	Remarks
Pre1	
Pre2	
1.1(1)	
1.1(2)	
1.2(1)	
1.2(2)	
1.3	
1.4(1)	
1.4(2)	
1.5(1)	
1.5(2)	
2.1	

2.2(1)	
2.2(2)	
2.3(1)	
2.3(2)	
3a(1)	
3a(2)	
3a(3)	
3s(1)	
3s(2)	
3s(3)	
3m(1)	
3m(2)	
3m(3)	
3d(1)	
3d(2)	
3d(3)	

Interview Record

Date: _____ Interviewer's name: _____

School: _____ Student's name: _____ Grade & Class: _____

【Natural number】

Task	Remarks
Pre1	
Pre2	
1.1(1)	
1.1(2)	
1.2(1)	
1.2(2)	
1.3	
1.4(1)	
1.4(2)	
1.5(1)	
1.5(2)	

[Decimal number]

Task	Remarks
1.1(1)	
1.1(2)	
1.2(1)	
1.2(2)	
1.3(1)	
1.3(2)	
1.4(1)	
1.4(2)	
1.5(1)	
1.5(2)	
2.1	
2.2(1)	
2.2(2)	
2.3(1)	
2.3(2)	

3a(1)	
3a(2)	
3a(3)	
3s(1)	
3s(2)	
3s(3)	
3m(1)	
3m(2)	
3m(3)	
3d(1)	
3d(2)	
3d(3)	

No. _____

For Grade 3 and 4

Name: _____ Age _____ Grade and Class _____

1. What number is indicated by the arrow on the number line?

Local language: Ka arrow, ka sonta pa namba bwanji pa namba line?

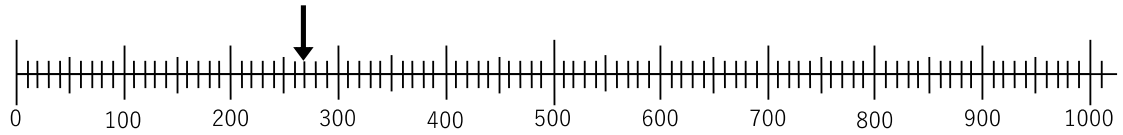

Answer (**Ansa**). _____

2. Where is 420 on the number line? Indicate the above number with an arrow ↓.

Local language: 420 ili pati pa namba line? Onesa kusebenzesa ka arrow ↓.

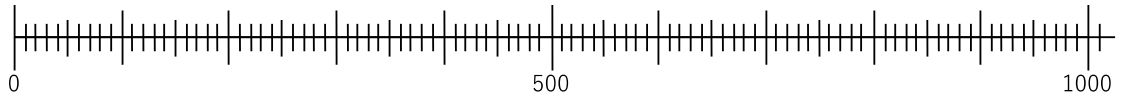

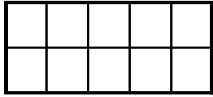
3. If the whole of this grid  represents 100, what number is represented by the circled grids/boxes?

Local language: Ngati aka ka grid konse katantauza 100, tuma grid/box twamene ba sekoling'a tutantauza namba bbwanji?

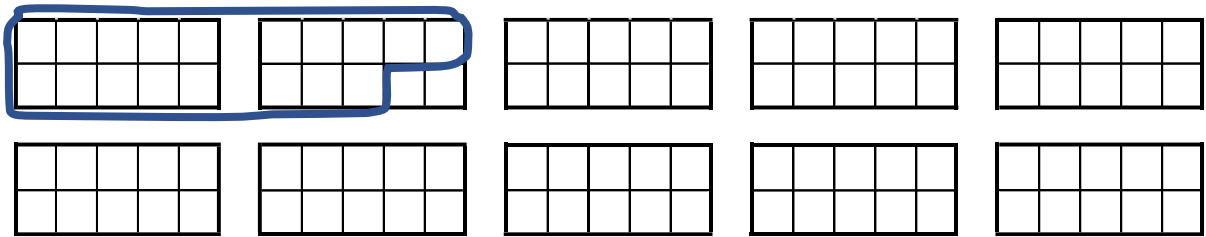

Answer (Ansa). _____

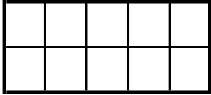



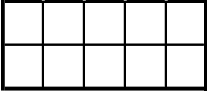
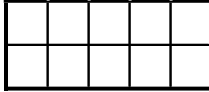
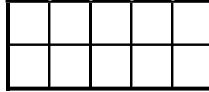
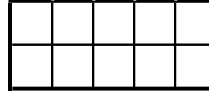
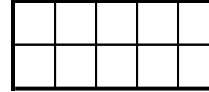
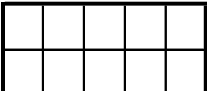
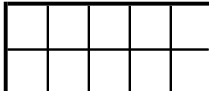
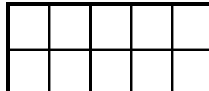
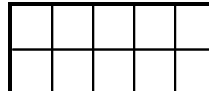
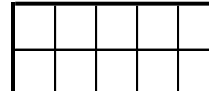





4. (1) If the whole of this grid  represents 100, circle 260 using the grids/boxes.

Local language: Ngati aka ka grid konse katantauza 100, sekoling'a 260 kusebenzesa tuma grid/box.

4. (2) If the whole of this grid  represents 100, circle 490 using the grids/boxes.

Local language: Ngati aka ka grid konse katantauza 100, sekoling'a 490 kusebenzesa tuma grid/box.

5. If \square represents 1, rectangle represents 10 and square represents 100,
draw the tiles which represent 234.

Local language: Ngati \square nika 1 tile, rectangle nika 10 tile elo square nika
100 tile, drawing'a tuma tiles twamene tutantauza ma namba 234.

234		
100s	10s	1s

6. The whole of this grid  represents 100. If the circled grids represent a number, where is that number on the number line?

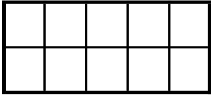

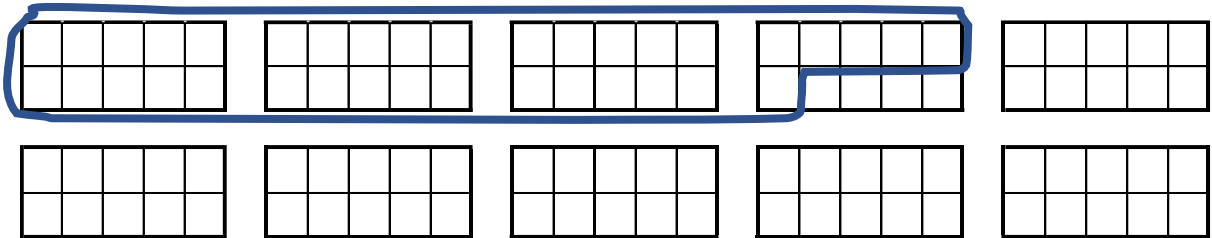
Local language: Ngati aka ka grid konse katantauza **100**, namba yamene ta sekoling'a ili pati pa namba line?



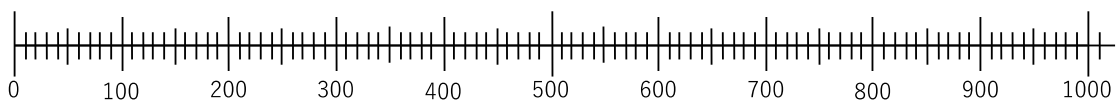

Answer (**Ansa**). Indicate the above number with an arrow ↓ here.

Local language: Kuebezesa ka arrow ↓ , onesa namba yamene wapeza pa namba line iyi

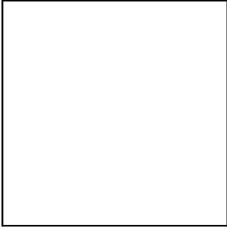

7. If  represents 1,  represents 10 and  represents 100, circle the letter A or B which has the bigger number.

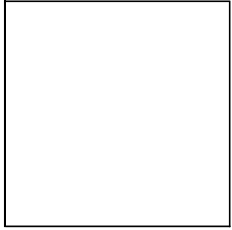
Local language: Ngati  nika 1 tile,  nika 10 tile elo  nika

100 tile, sekoling'a letta pali A olo B yamene ili na namba ikulu.

A.

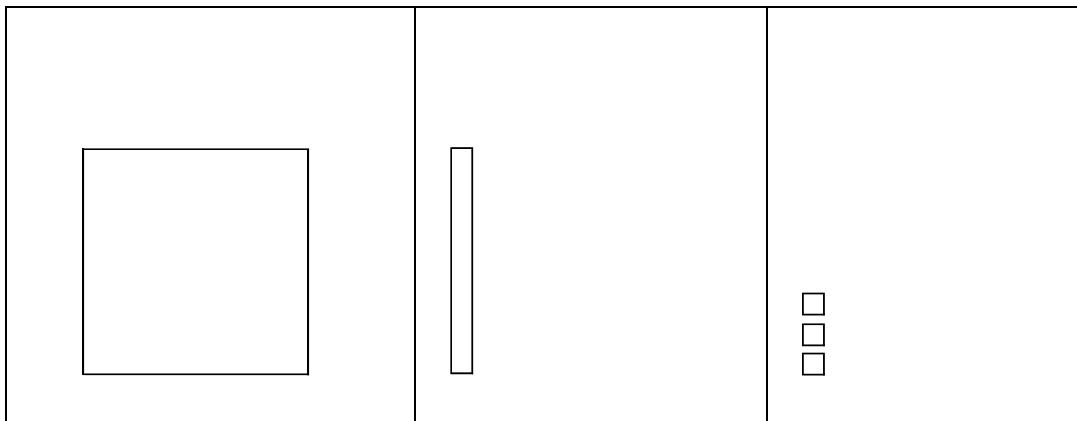

B.

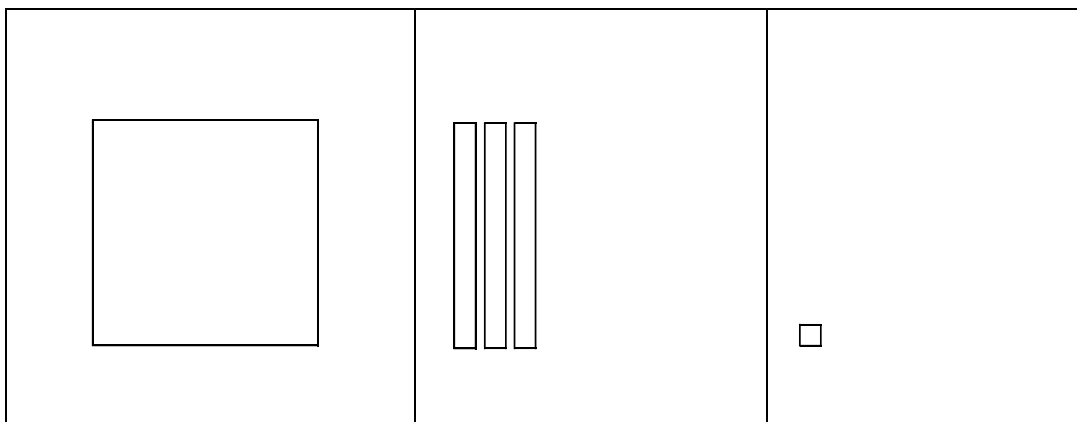

8. On the number line below, circle the letter which points to the bigger number,

A or B.

Local language: Pa namba line ili pansi apa, sekoling'a letta yamene isonta pa namba ikulu A olo B.



9 (1) Which is bigger 240 or 280 ?

Local language: Niyiti namba ikhulu, 240 olo 280?

Answer (Ansa). _____

9 (2) Which is bigger 350 or 620 ?

Local language: Niyiti namba ikhulu, 350 olo 620?

Answer (Ansa). _____

10. (1) Write the times sentence that represents $120+120+120+120=480$

Local language: Lemba namba ya taimuzi yamene itantauza

$$120 + 120 + 120 + 120 = 480$$

Multiplication(times) sentence (Sentence ya taimuzi).

10. (2) If \square represents 1, $\begin{array}{|c|} \hline \\ \hline \end{array}$ represents 10 and \square represents 100,

draw tiles to show 3×210

Local language: Ngati \square nika 1 tile, $\begin{array}{|c|} \hline \\ \hline \end{array}$ nika 10 tile elo \square nika 100

tile, drawing'a ma tiles kuonesha 3×210

Answer (Ansa).

11. (1) Write a division sentence for the diagram.

Local language: Lemba sentence ya divide by kuonesa division iyi.

Division sentence (Sentence ya division).

480

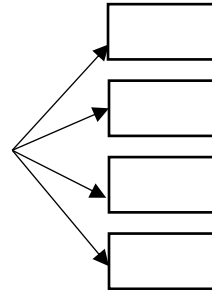

11. (2) If \square represents 1, rectangle represents 10 and square represents 100,

draw tiles to show $390 \div 3$

Local language: Ngati \square nika 1 tile, rectangle nika 10 tile elo square nika

100 tile, drawing'a ma tiles kuonesa $390 \div 3$

Answer (Ansa).

12. Calculate and show your work on this paper.

Local language: Peza ma ansa ya masamu aya. Onesa mwamene wapezela ma ansa pa pepala pamene.

$$(a) \quad 178 + 213 =$$

$$(b) \quad 286 - 147 =$$

$$(c) \quad 230 \times 3 =$$

$$(d) \quad 480 \div 4 =$$

13. Mrs Banda had 360 mangos.

If she shared that among three (3) people equally. How many mangos did each person get? Show your work.

Local language: Ba Mrs. Banda banali na mango yali 360. Babagabanisa bantu batatu (3) molingana. Umodzi anatenga mango yangati? Onesa mwamene waipezela ansa.

Show your work (Onesa mwamene waipezela ansa).

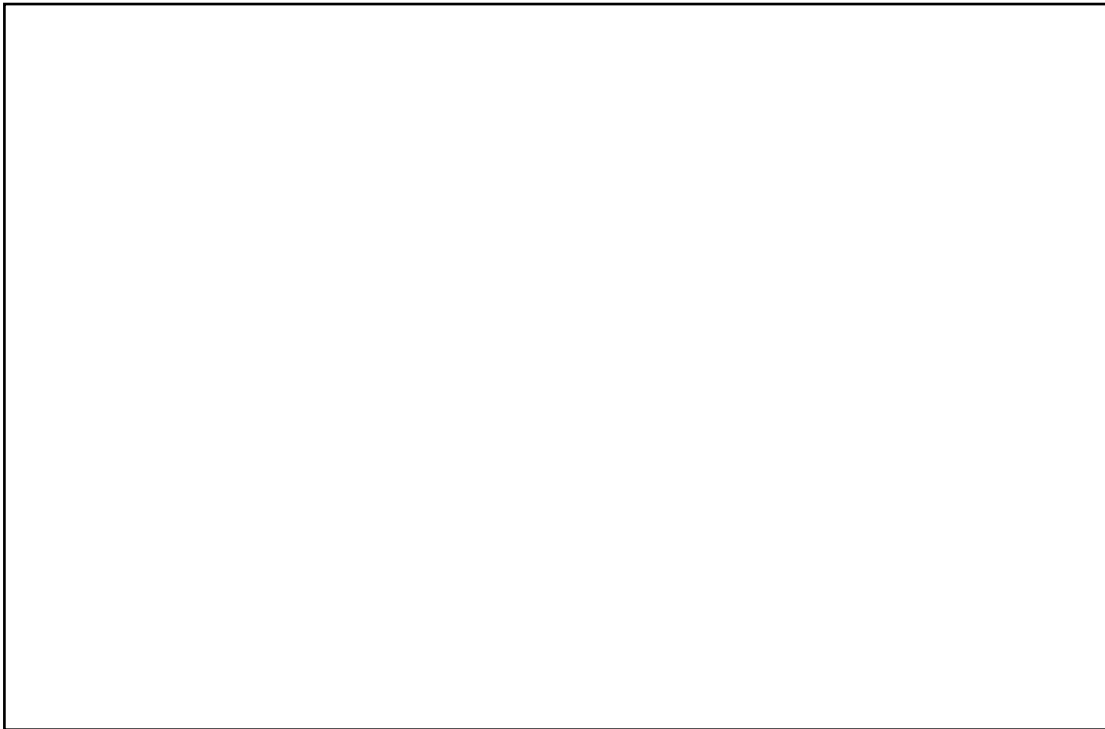

Math sentence (Sentence ya masanu). _____

No. _____

For Grade 5 and 6

Name: _____ Age _____ Grade and Class _____

1. Where is 420 on the number line? Indicate with an arrow ↓ .

Local language: 420 ili pati pa namba line? Onesa kusebenzesa ka arrow ↓ .

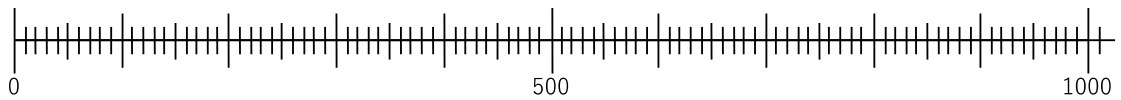

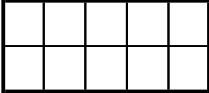
2. If the whole of this grid  represents 100, circle 260 using the grids/boxes.

Local language: Ngati aka ka grid konse katantauza 100, sekoling'a 260 kusebenzesa tuma grid/box.

3. If \square represents 1, rectangle represents 10 and square represents 100, draw the tiles which represent 234.

Local language: Ngati \square nika 1 tile, rectangle nika 10 tile elo square nika

100 tile, drawing'a tuma tiles twamene tutantauza ma namba 234.

234		
100s	10s	1s

4. Where is 4.2 on the number line? Indicate with an arrow ↓ .

Local language: 4.2 ili pati pa namba line? Onesa kusebenzesa ka arrow ↓ .

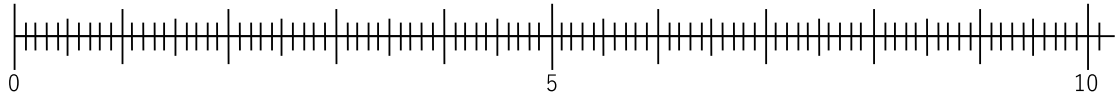

5. What number is indicated by the arrow on the number line?

Local language: Ni namba bwanji, pamene ka sonta Ka arrow pa namba line?

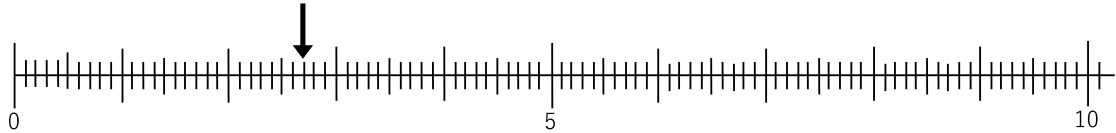

Answer (**Ansa**). _____

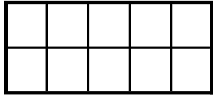
6. If the whole of this grid  represents 1, what number is represented by the circled grids/boxes?

Local language: Ngati aka ka grid konse katantauza 1, tuma grid/box twamene ba sekoling'a tutantauza namba bbwanji?

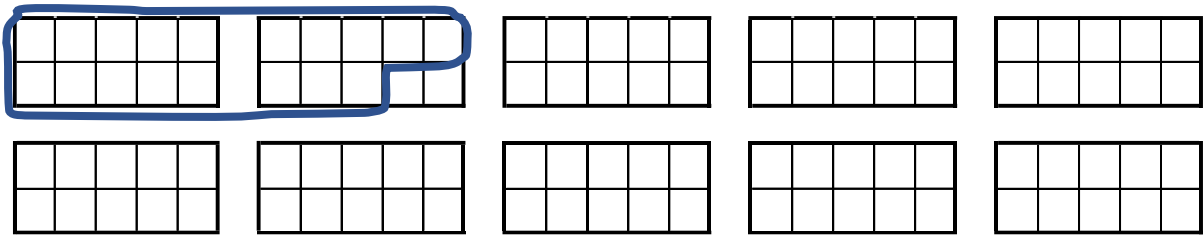

Answer (Ansa). _____

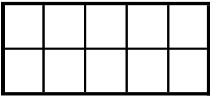
7. If the whole of this grid  represents 1, circle 2.6 using the grids/boxes.

Local language: Ngati aka ka grid konse katantauza 1, sekoling'a 2.6
kusebenzesa tuma grid/box.

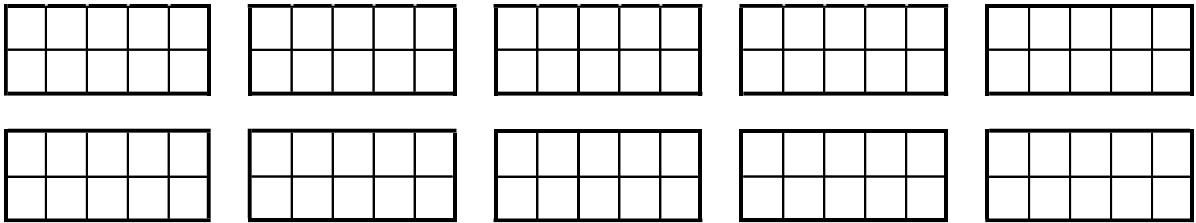

8. If \square represents 0.1, \square represents 1 and \square represents 10,
draw the tiles which represent 23.4.

Local language: Ngati \square nika 0.1 tile, \square nika 1 tile elo \square nika
10 tile, drawing'a tuma tiles twamene tutantauza 23.4.

23.4		
10s	1s	0.1s

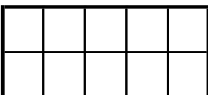
9. The whole of this grid  represents 1. If the circled grids represent a number, where is that number on the number line?

Local language: Ngati aka ka grid konse katantauza 1, namba yamene ta sekoling'a ili pati pa namba line?

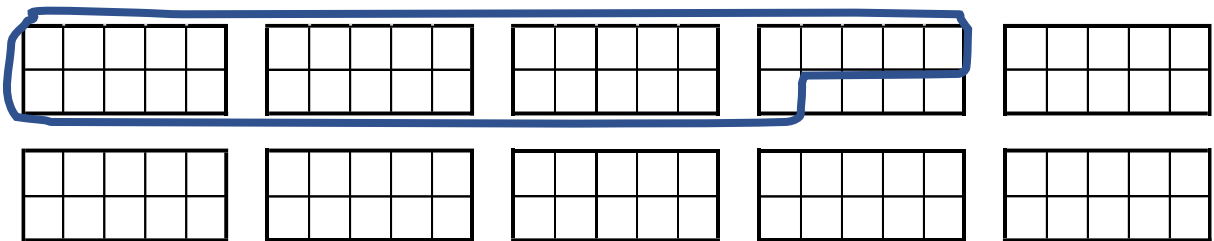

Answer (**Ansa**). Indicate the above number with an arrow ↓ here.

Local language: Kuebezesa ka arrow ↓ , onesa namba yamene wapeza pa namba line iyi.

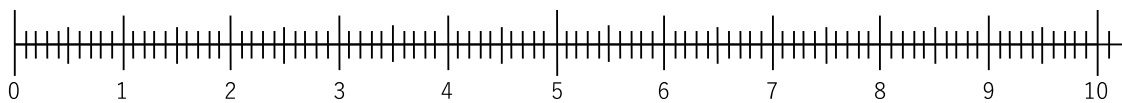

10. If \square represents 0.1, rectangle represents 1 and square represents 10.

Which number is bigger between the one represented in A and the one represented in B? Circle the letter A or B which has the bigger number.

Local language: Ngati \square nika 0.1 tile, rectangle nika 1 tile elo square nika

10 tile, ni iti namba ikulu pali ili pa A na ili pa B? Sekoling'a letta pali A olo B yamene ili nan amba ikulu.

A.

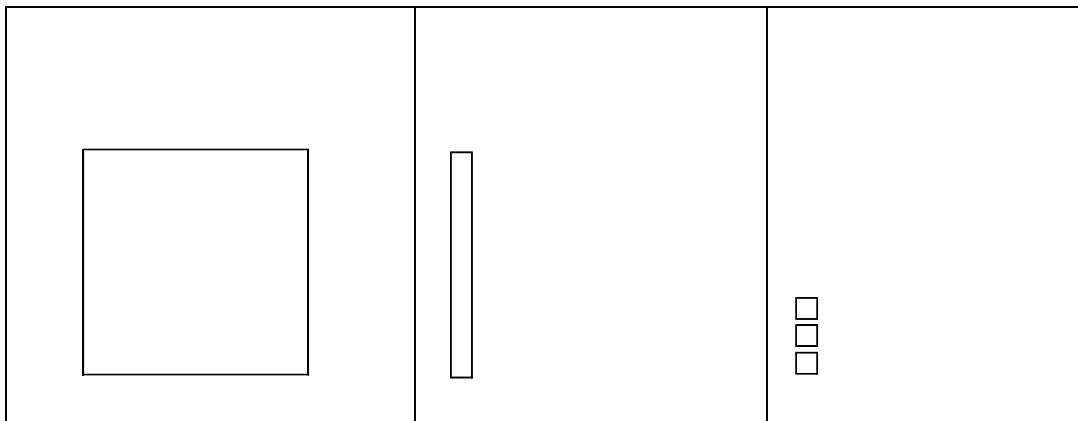

B.

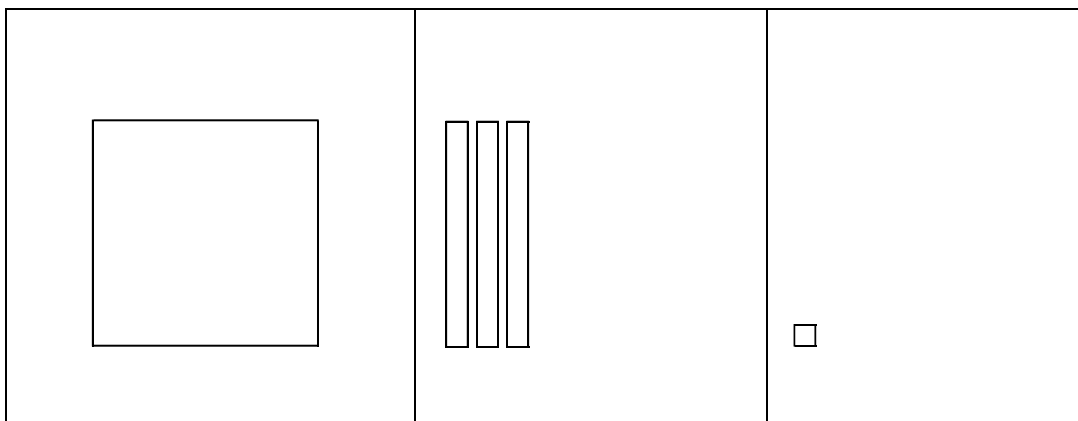

11. On the number line below, circle the letter which points to the bigger number,

A or B.

Local language: Pa namba line ili pansi apa, sekoling'a letta yamene isonta pa namba ikulu A olo B.

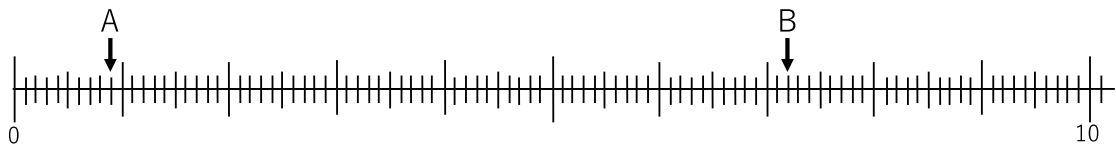

12 (1) Which is bigger 2.4 or 2.7 ?

Local language: Niyiti namba ikhulu, 2.4 olo 2.7 ?

Answer (Ansa). _____

12 (2) Which is bigger 1.8 or 3.4 ?

Local language: Niyiti namba ikhulu, 1.8 olo 3.4 ?

Answer (Ansa). _____

13. (1) Write the times sentence that represents $1.2 + 1.2 + 1.2 + 1.2 = 4.8$

Local language: Lemba namba ya taimuzi yamene itantauza

$$1.2 + 1.2 + 1.2 + 1.2 = 4.8$$

Multiplication(times) sentence (*Sentence ya taimuzi*).

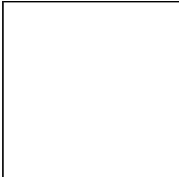
13.(2) If \square represents 0.1,  represents 1 and  represents 10,

draw tiles to show 3×2.1

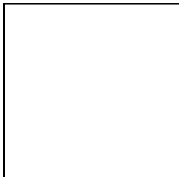
Local language: Ngati \square nika 0.1 tile,  nika 1 tile elo  nika 10

tile, drawing'a ma tiles kuonesha 3×2.1

Answer (*Ansa*).

14. (1) Write a division sentence for the diagram.

Local language: Lemba namba sentence ya divide by kuonesa division iyi.

Division sentence (Sentence ya division).

4.8

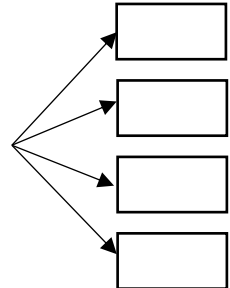

14.(2) If \square represents 0.1, ▮ represents 1 and \square represents 10,

draw tiles to show $3.9 \div 3$

Local language: Ngati \square nika 0.1 tile, ▮ nika 1 tile elo \square nika

10 tile, drawing' a ma tiles kuonesa $3.9 \div 3$

Answer (Ansa).

15. Calculate and show your work on this paper.

Local language: Peza ma ansa ya masamu aya. Onesa mwamene wapezela ma ansa pa pepala pamene.

$$(a) \quad 17.8 + 21.3 =$$

$$(b) \quad 28.6 - 14.7 =$$

$$(c) \quad 2.3 \times 3 =$$

$$(d) \quad 4.8 \div 4 =$$

16. There is a total of **18.6** liters of Orange Juice.

If we share that among three (**3**) people equally, how many liters will each one gets? Show your work.

Local language: Kuli **18.6** litres ya orange juice. Ngati tagabanisa bantu batatu (**3**) molingana, muntu umodzi anatenga ma litres yangati? Onesa mwamene waipezela ansa.

Show your work (*Onesa mwamene waipezela ansa*).

Math sentence (*Sentence ya masamu*). _____

Natural number

School: _____

Grade and Class: _____

Name: _____

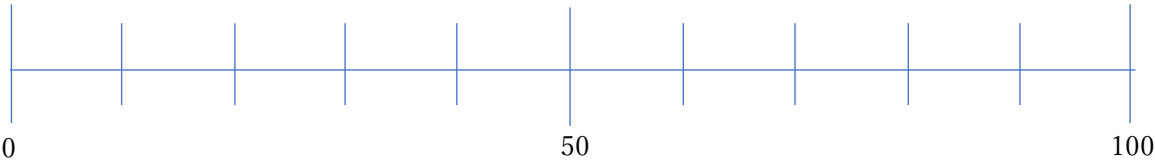
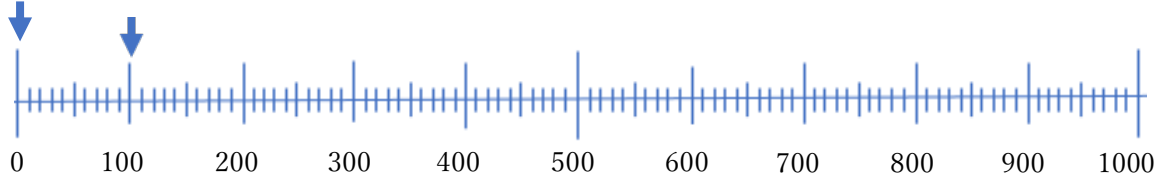
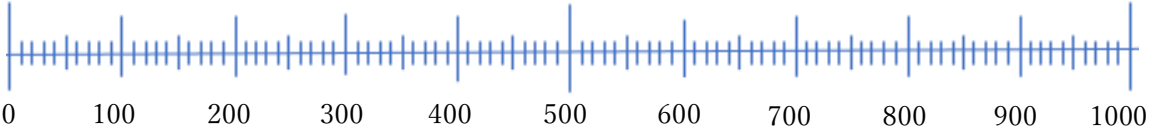
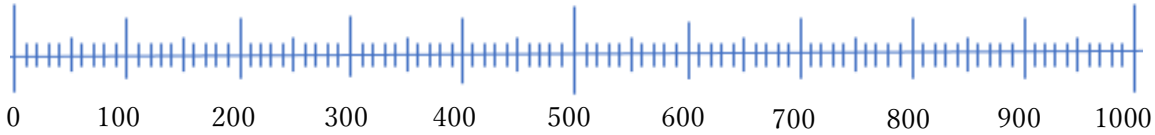
Task	Answer
Pre1	
Pre2	
1.1(1)	<p>What number is this ?</p>  <p>What does each small line represent?</p>
1.1(2)	<p>Count up to 300.</p> 
1.2(1)	<p>Indicate the number 260 with an arrow.</p> 

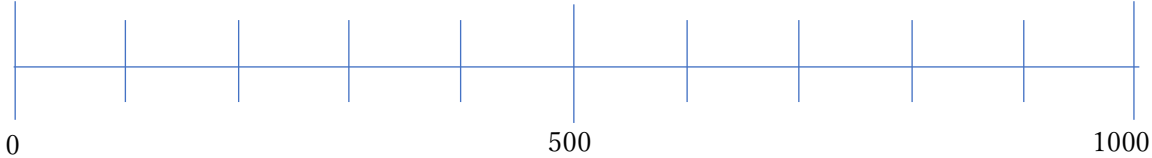
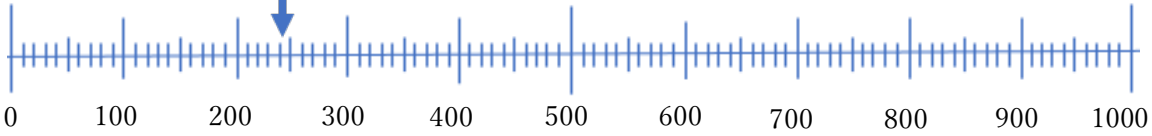
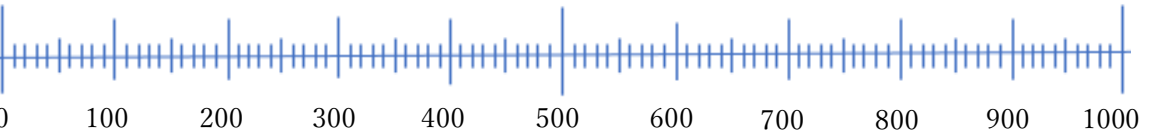
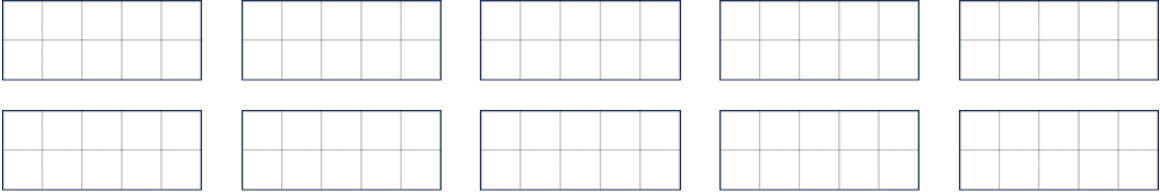
<p>1.2(2)</p>	<p>Indicate the number 260 with an arrow.</p> 
<p>1.3</p>	<p>What number does the marked arrow represent?</p> 
<p>1.4(1)</p>	<p>What does the circled boxes represent?</p>
<p>1.4(2)</p>	<p>Mark the above number with an arrow.</p> 
<p>1.5(1)</p>	<p>Circle the amount of 260.</p> 

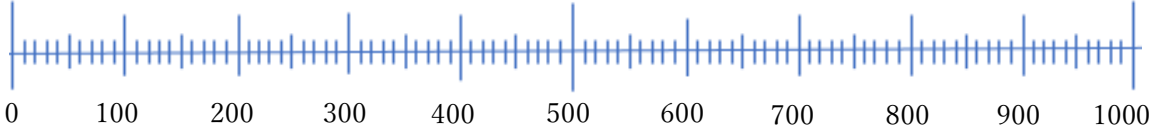
1.5(2)	<p>Circle the amount of 260.</p> 
2.1	<p>Arrange [400, 80, 210] in order from smallest to biggest.</p>
2.2(1)	<p>Which is bigger, 342 or 350?</p>
2.2(2)	<p>Explain the reason using tiles.</p>
2.3(1)	<p>Arrange [50, 370, 160] in order from smallest to biggest with arrows.</p> 
2.3(2)	<p>[Reason]</p>
3a(1)	<p>330 + 135 [calculation in column]</p> $ \begin{array}{r} 330 \\ + 135 \\ \hline \end{array} $

3a(2)	330 + 135 [tiles]
3a(3)	330 + 135 [reason]
3s(1)	385 – 152 [calculation in column] $\begin{array}{r} 385 \\ - 152 \\ \hline \end{array}$
3s(2)	385 – 152 [tiles]
3s(3)	385 – 152 [reason]
3m(1)	240 × 3 [calculation in column] $\begin{array}{r} 240 \\ \times 3 \\ \hline \end{array}$
3m(2)	240 × 3 [tiles]
3m(3)	240 × 3 [reason]

3d(1)	360÷3 [calculation in column] $3 \overline{) 360}$
3d(2)	360÷3 [tiles]
3d(3)	360÷3 [reason]

Natural number & Decimal number

School: _____ Grade and Class: _____

Name: _____

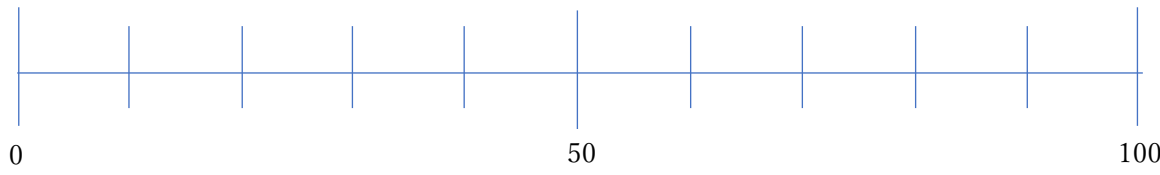
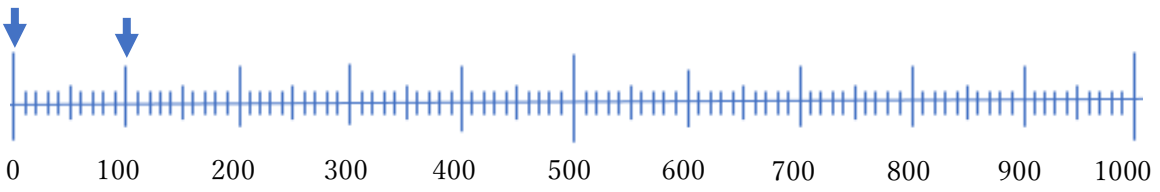
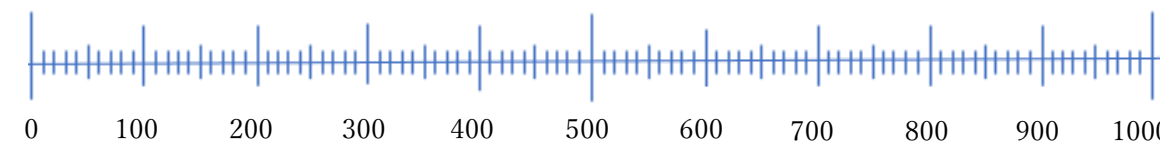
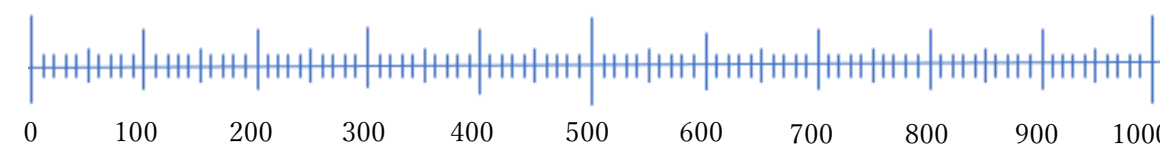
Task	Answer
Pre1	
Pre2	
1.1(1)	<p>What number is this ?</p>  <p>What does each small line represent?</p>
1.1(2)	<p>Count up to 300.</p> 
1.2(1)	<p>Indicate the number 260 with an arrow.</p> 

1.2(2) Indicate the number 260 with an arrow.

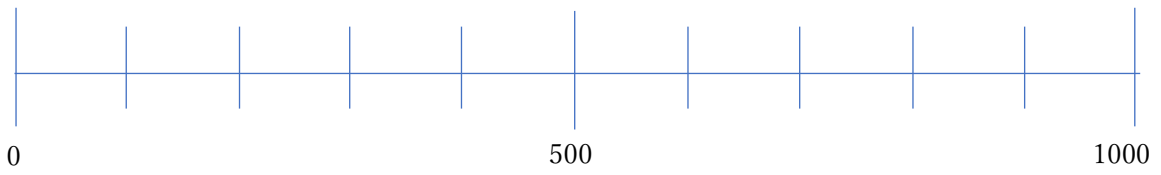

1.3 What number does the marked arrow represent?

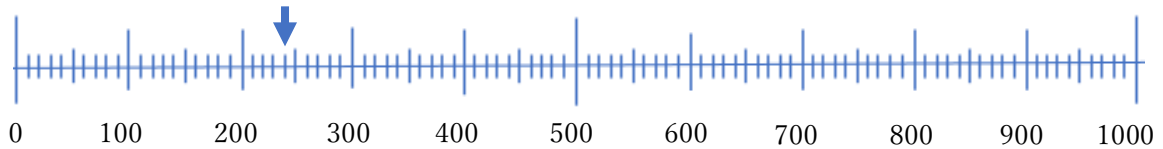

1.4(1) What does the circled boxes represent?

1.4(2) Mark the above number with an arrow.

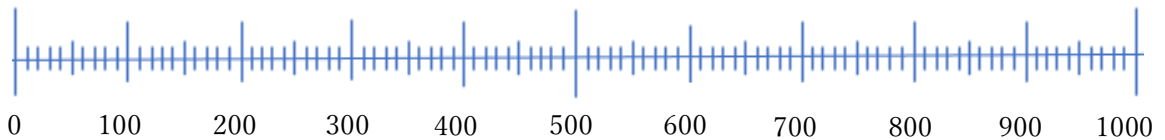



1.5(1) Circle the amount of 260.

<input type="checkbox"/>	<input type="checkbox"/>	<input type="checkbox"/>	<input type="checkbox"/>	<input type="checkbox"/>
<input type="checkbox"/>	<input type="checkbox"/>	<input type="checkbox"/>	<input type="checkbox"/>	<input type="checkbox"/>

1.5(2) Circle the amount of 260.

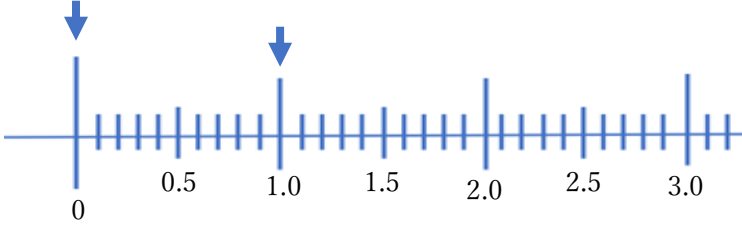
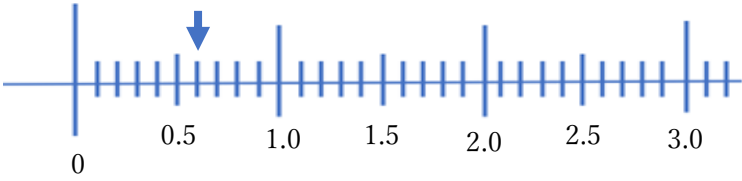
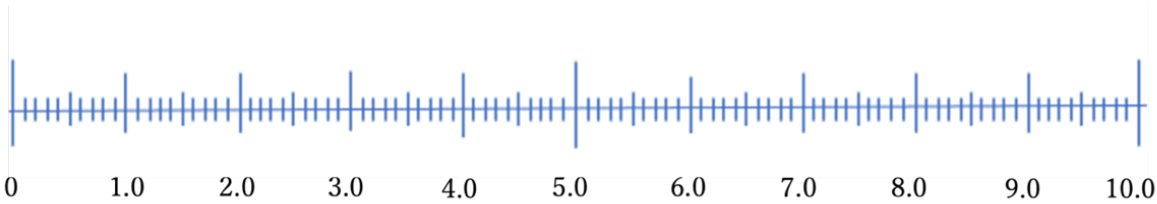
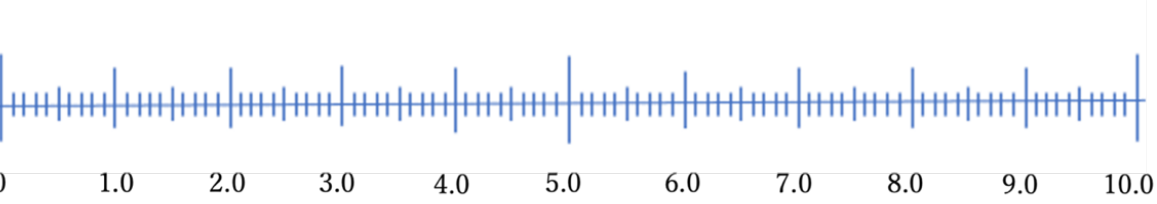
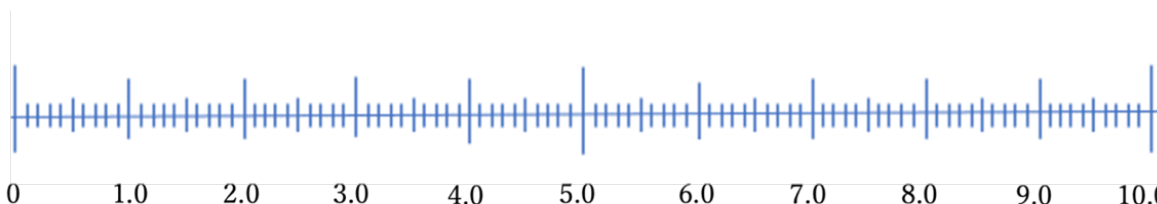
<input type="checkbox"/>	<input type="checkbox"/>	<input type="checkbox"/>	<input type="checkbox"/>	<input type="checkbox"/>
<input type="checkbox"/>	<input type="checkbox"/>	<input type="checkbox"/>	<input type="checkbox"/>	<input type="checkbox"/>

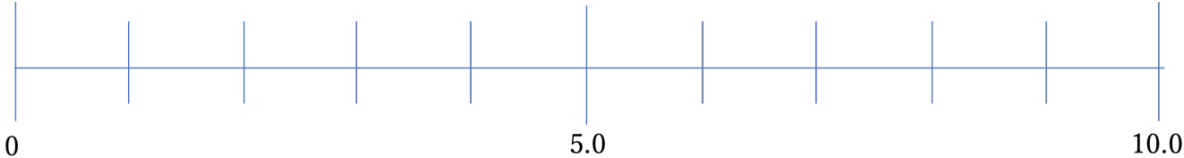
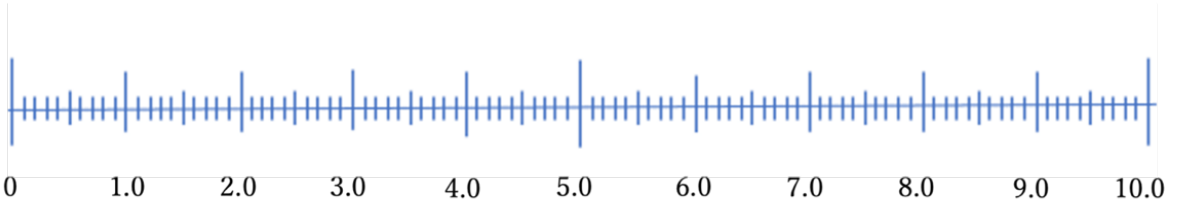
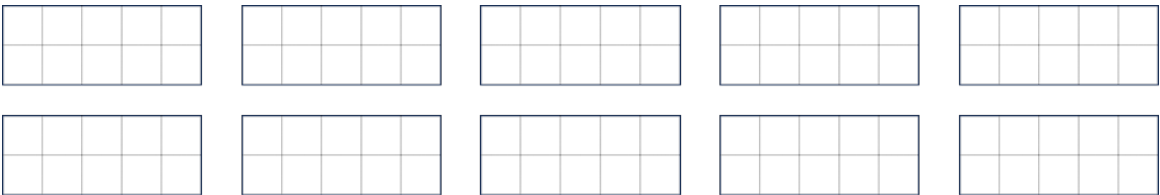
1.1(1)	<p>What number is this?</p> 
1.1(2)	<p>What number does the marked arrow?</p> 
1.2(1)	<p>What does each small line represent?</p> 
1.2(2)	<p>Count up to 3.0</p> 
1.3(1)	<p>Indicate the number 2.6 with an arrow.</p> 

<p>1.3(2)</p>	<p>Indicate the number 2.6 with an arrow.</p> 
<p>1.4(1)</p>	<p>What does the circled boxes represent?</p>
<p>1.4(2)</p>	<p>Mark the above number with an arrow.</p> 
<p>1.5(1)</p>	<p>Circle the amount of 2.6</p> 
<p>1.5(2)</p>	<p>Circle the amount of 2.6</p> 
<p>2.1</p>	<p>Arrange [1.2, 0.8, 2.1] in order from smallest to biggest.</p>

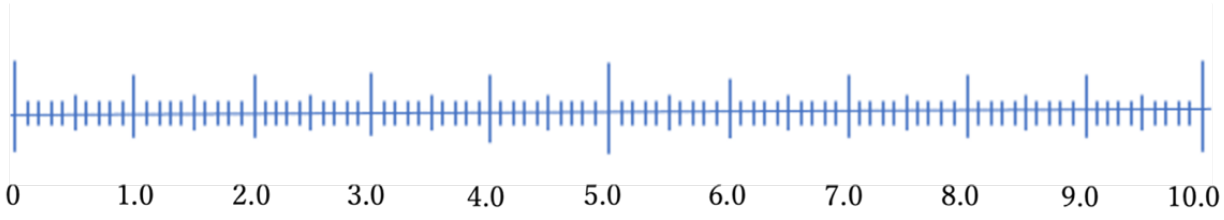
2.2(1)	Which is bigger, 3.5 or 1.6?
2.2(2)	Explain the reason by using tiles.
2.3(1)	Arrnage [1.6, 3.7, 0.5] in order from smallest to biggest with arrows. 
2.3(2)	Which arrow represent bigger number? [reason]

3a(1)	<p>33.1 + 13.5 [calculation in column]</p> $\begin{array}{r} 33.1 \\ + 13.5 \\ \hline \end{array}$
3a(2)	33.1 + 13.5 [tiles]
3a(3)	33.1 + 13.5 [reason]
3s(1)	<p>3.5 – 1.5 [calculation in column]</p> $\begin{array}{r} 3.5 \\ - 1.5 \\ \hline \end{array}$
3s(2)	3.5 – 1.5 [tiles]

3s(3)	3.5 – 1.5 [reason]
3m(1)	2.4 × 3 [calculation in column] $\begin{array}{r} 2.4 \\ \times 3 \\ \hline \end{array}$
3m(2)	2.4 × 3 [tiles]
3m(3)	2.4 × 3 [reason]

3d(1)	$3.6 \div 3$ [calculation in column] $3 \overline{) 3.6}$
3d(2)	$3.6 \div 3$ [tiles]
3d(3)	$3.6 \div 3$ [reason]

**Grade
3 & 4**

Pupil's

Workbook

• Representing • Comparing • Calculating

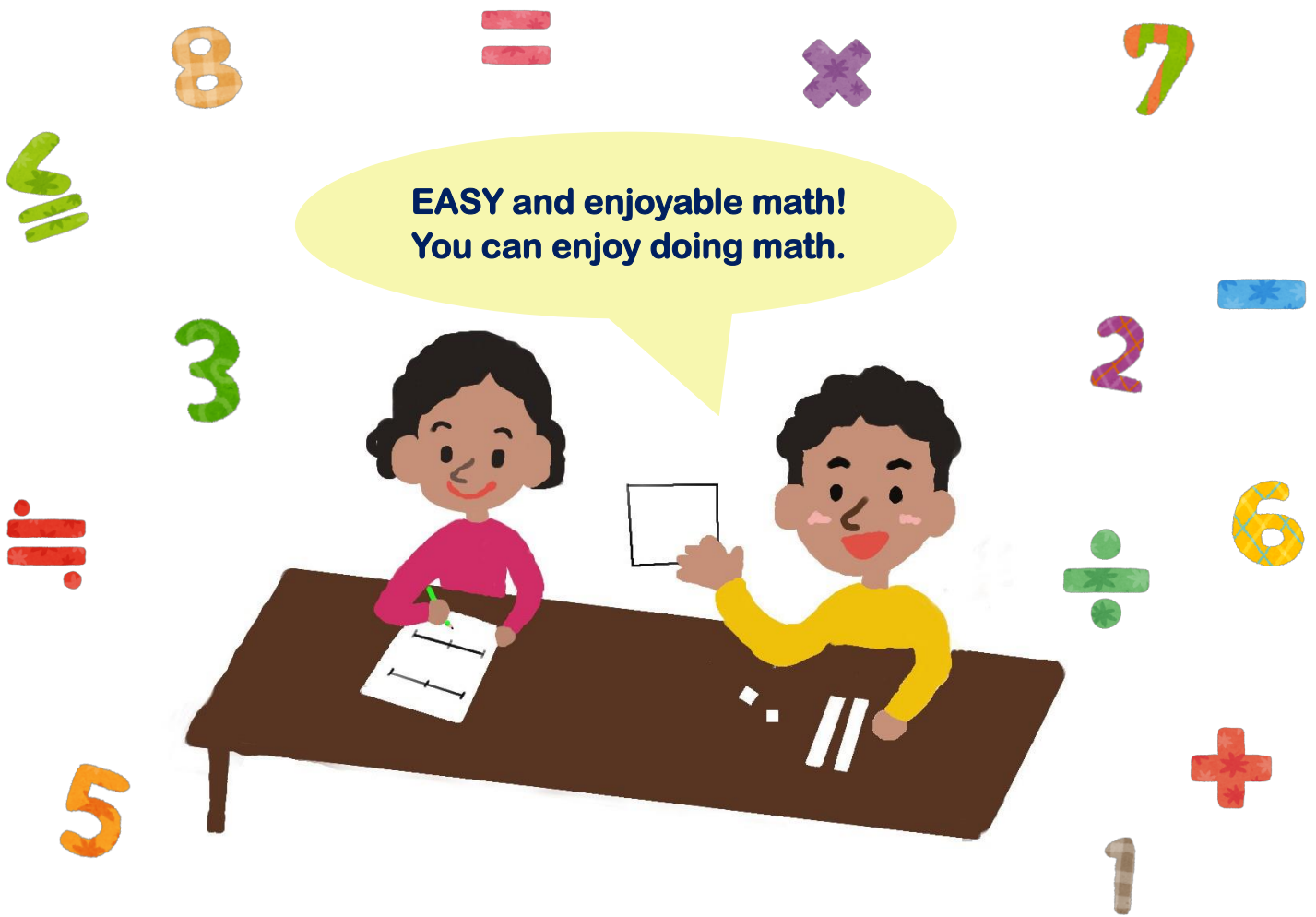

School: _____

Name: _____

Title: Pupils' workbook Grade 3 & 4
Author: ABE, Yoshitaka
BABA, Takuya
CHIKOLA, Doye
KAABO, Emmanuel
KOSAKA, Masato
KUSAKA, Satoshi
MAMBWE, Bareford
MINAGOSHI, Kanae
MUDENDA, Barbara
MUNGALU, Arthur
NAKAWA, Nagisa
NALUBE, Patricia
NKHATA, Bentry
SIKWALE, Shelly
TAFENI, Spiwe
TAKUZWA, Jane, Njovu
WATANABE, Koji
YUDA, Shiori

Acknowledgment: The authors thank Professors Joanne Mulligan and Michael Mitchelmore, School of Education, Macquarie University, Sydney, Australia for their expert guidance and review of the document.

Copyright © 2024, All Rights Reserved.

Pepala yolangiza pamene muyendela

Dzina:

Siku	Zamkati
Example 30 March	Extra A
	Extra activity A
	Practice 1
	Practice 2
	Extra activity B
	Practice 3
	Practice 4
	Practice 5
	Extra activity C
	Extra activity D
	Extra activity E
	Practice 6
	Extra activity F
	Practice 7
	Extra activity G
	Practice 8
	Extra activity H
	Extra activity I
	Practice 9

Siku	Zamkati
	Practice 10
	Extra activity J
	Practice 11
	Extra activity K
	Extra activity L
	Practice 12
	Practice 13
	Practice 14

Vili Mu Book

I . Mo onetsela	1
Extra activity A; Ma namba tingayaonese bwanji kusebenzesa ma grid?.....	2
Practice 1; Ma namba tingayaonese bwanji kusebenzesa ma grid?.....	3
Practice 2; Ma namba tingayaonese bwanji kusebenzesa ma grid?.....	4
Extra activity B; Ma namba tingayaonese bwanji kusebenzesa numba line?.....	5
Practice 3; Ma namba tingayaonese bwanji kusebenzesa numba line?.....	6
Practice 4; Ma namba tingayaonese bwanji kusebenzesa numba line?.....	7
Practice 5; Ma namba tingayaonese bwanji? Kulinganiza njila zosiyana zooneselamo ma namba.....	8
Extra activity C; Ma namba tingayaonese bwanji kusebenzesa ma tile?.....	9
Extra activity D; Yesa ku drawing'a ma tiles.....	10
II . Kulinganiza	12
Extra activity E; Niyiti ikulu kusebenzesa ma tiles?.....	13
Practice 6; Niyiti ikulu kusebenzesa ma tiles?.....	14
Extra activity F; Niyiti ikulu kusebenzesa ma namba?.....	15
Practice 7; Niyiti ikulu kusebenzesa ma namba?.....	16
Extra activity G; Niyiti ikulu kusebenzesa numba line?.....	17
Practice 8; Niyiti ikulu kusebenzesa numba line?.....	18

III. Kupeza masamu	19
Extra activity H; Kusankaniza tichita bwanji?.....	20
Extra activity I; Kuchotsera tichita bwanji?.....	21
Practice 9; Kusankaniza muma colamu.....	22
Practice 10; Kuchotsera muma colamu.....	23
Extra activity J; Ma samu ya times tichita bwanji?.....	24
Practice 11; Ma samu ya times tichita bwanji?.....	25
Extra activity K; Ma samu ya divaidi by tichita bwanji? (1)	26
Extra activity L; Ma samu ya divaidi by tichita bwanji? (2)	27
Practice 12; Ma samu ya divaidi by tichita bwanji?.....	29
Practice 13; Ku peza ma samu ya times muma colamu.....	30
Practice 14; Ku peza ma samu ya divaidi by muma colamu.....	31

I . Mo onetsela



Choyamba, tizaphunzila molangizila ma namba.
Tiyeni tiphunzile njila zosiyana zolangizila ma
namba na kulondolola?

Extra

A

Ma namba tingayaonese bwanji kusebenzesa ma grid?

Date

/ 5 Points

① Gaba grid muma part yali 10 yolingana.

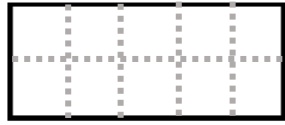

Nasiliza!

② Gaba grid muma part yali 10 yolingana.



Nasiliza!

③ Gaba grid muma part yali 10 yolingana.

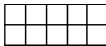

Nasiliza!

④ Ngati aka ka grid  konse katantauza 100, tuma grid/box twamene ba shading'a tutantauza namba bwanji?

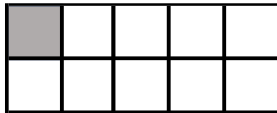

(Waziba bwanji?)

Nasiliza!

Ansa [_____]

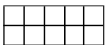
⑤ Ngati aka ka grid  konse katantauza 1000, tuma grid/box twamene ba shading'a tutantauza namba bwanji?

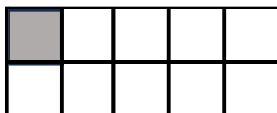

(Waziba bwanji?)

Nasiliza!

Ansa [_____]

- ① Ngati aka ka grid  konse katantauza 100, tuma grid/box twamene ba sekoling'a tutantauza namba bwanji?

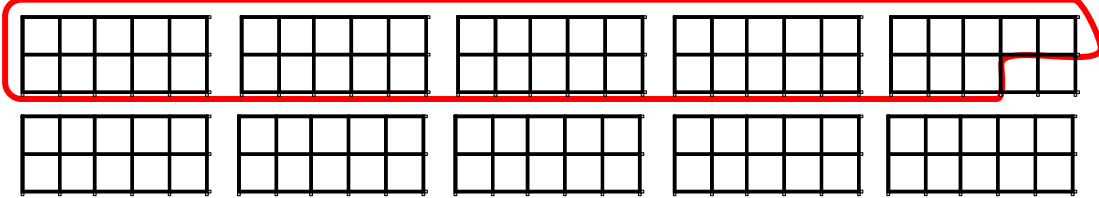

(Waziba bwanji?)

Ansa [_____]

- ② Ngati aka ka grid  konse katantauza 100, tuma grid/box twamene ba sekoling'a tutantauza namba bwanji?

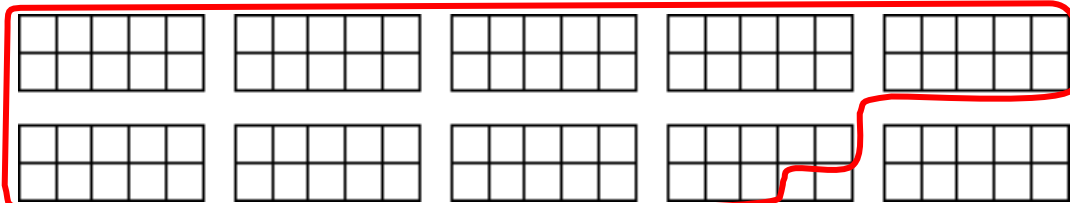



(Waziba bwanji?)

Ansa [_____]

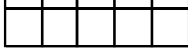

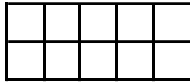
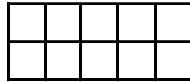

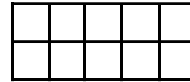
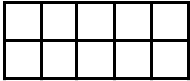
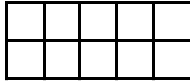
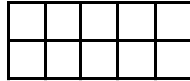
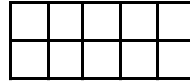
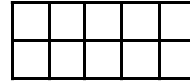

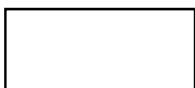
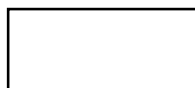
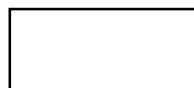

①

(1) Ngati aka ka grid  konse katantauza 100, sekoling'a 370 kusebenzesa tuma grid/box.

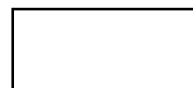
(Waziba bwanji?)





(2) Ngati aka ka grid  konse katantauza 100, sekoling'a 370 kusebenzesa tuma grid/box.

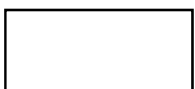
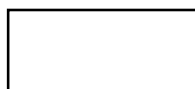
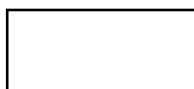

(Waziba bwanji?)

②

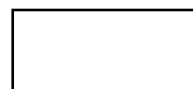
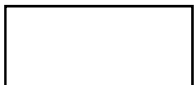
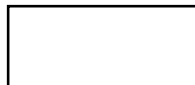
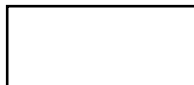
Ngati aka ka grid  konse katantauza 100, sekoling'a 720 kusebenzesa tuma grid/box.

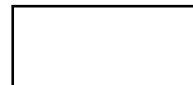
(Waziba bwanji?)

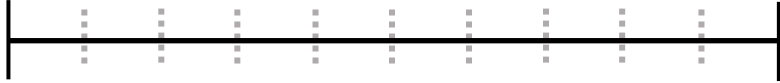
<p>① Gabanisa tunkale tolingana tuli 10. Penda ma part yonse kuyambila pa 0.</p> 	<input type="checkbox"/> Nasiliza!
<p>② Juba pakati elo ugabanise tunkale tolingana tuli 10. Penda ma part yonse kuyambila pa 0.</p> 	<input type="checkbox"/> Nasiliza!
<p>③ Juba pakati elo ugabanise tunkale tolingana tuli 10. Penda ma part yonse kuyambila pa 0.</p> 	<input type="checkbox"/> Nasiliza!
<p>④ Lemba ma numba yamene yafunika kunkala mu tuma box.</p>  <p>(Waziba bwanji?) 100 ili pa ka line kanamba 10, nishi koyambilila katantauza _____.</p>	<input type="checkbox"/> Nasiliza!
<p>⑤ Lemba ma numba yamene yafunika kunkala mu tuma box.</p>  <p>(Waziba bwanji?)</p>	<input type="checkbox"/> Nasiliza!

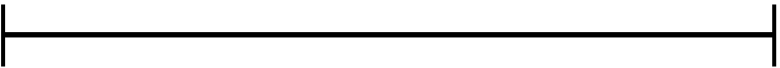
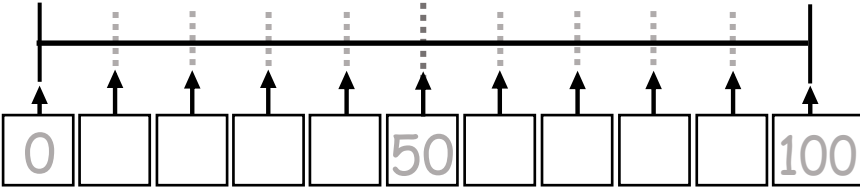
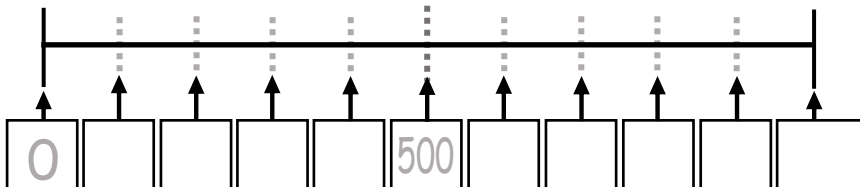
① Ka arrow, ka sonta pa numba bwanji pa numba line?

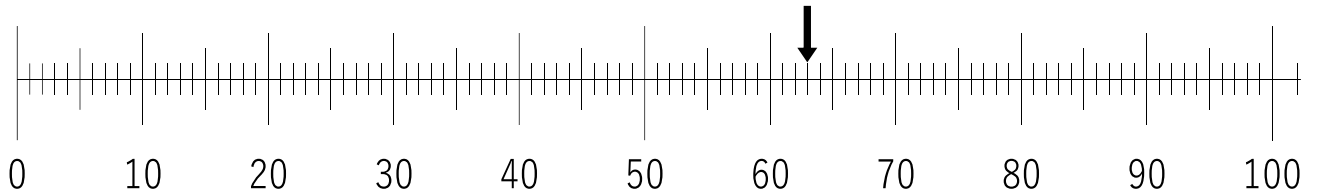

(Waziba bwanji?)

Ansa [_____]

② Ka arrow, ka sonta pa numba bwanji pa numba line?

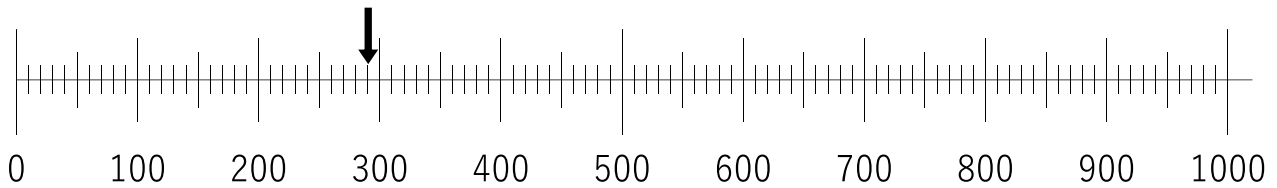

(Waziba bwanji?)

Ansa [_____]

③ Ka arrow, ka sonta pa numba bwanji pa numba line?

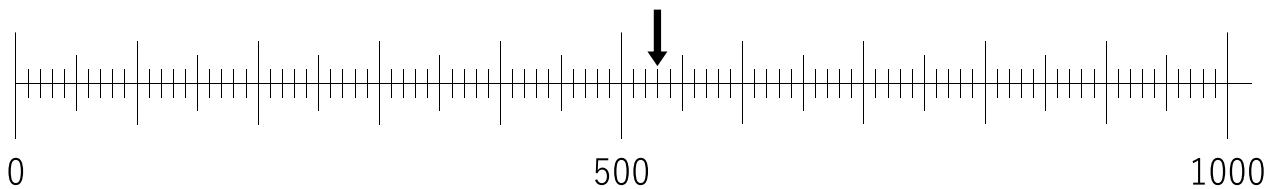

(Waziba bwanji?)

Ansa [_____]

Ika ka arrow pa ma namba line aya pamene pafunika ku nkhalama namba aya.

①

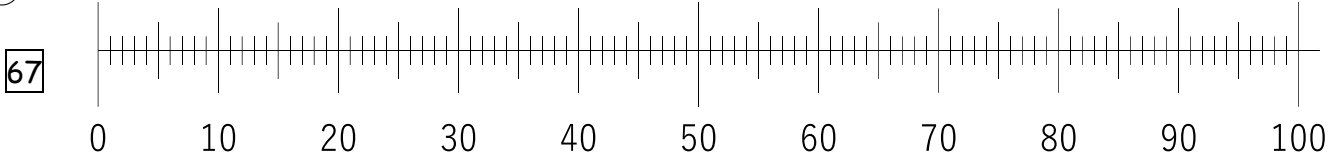

②

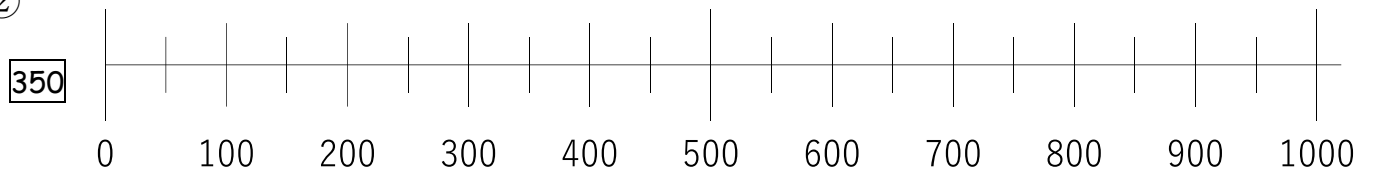

③

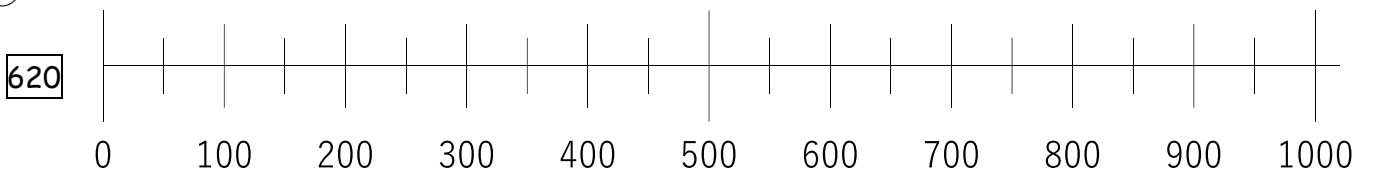

(Waziba bwanji?)

④

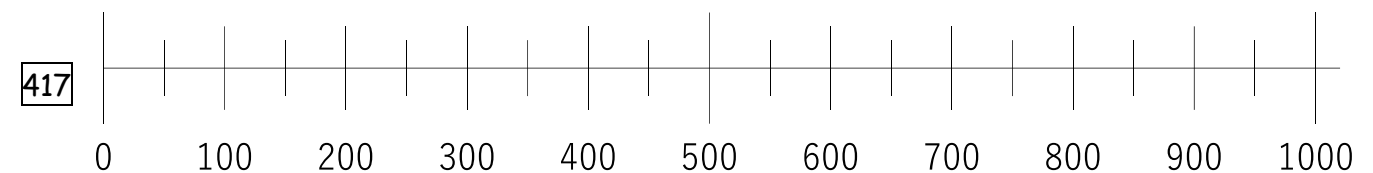

(Waziba bwanji?)

①

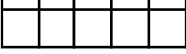
Ngati aka ka grid  konse katantauza 100, namba yamene ta sekoling'a ili pati pa namba line?

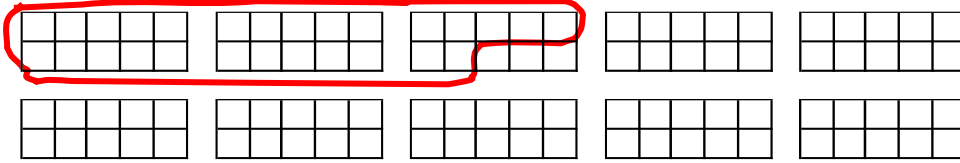

Kusebezesa ka arrow, onesa namba yamene wapeza pa namba line iyi.

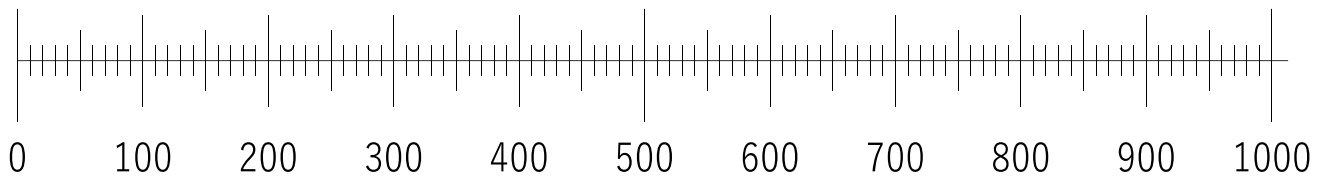

(Waziba bwanji?)

②

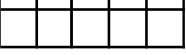
Ngati aka ka grid  konse katantauza 100, namba yamene ta sekoling'a ili pati pa namba line?

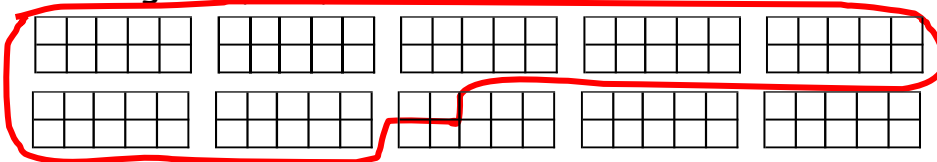

Kusebezesa ka arrow, onesa namba yamene wapeza pa namba line iyi.

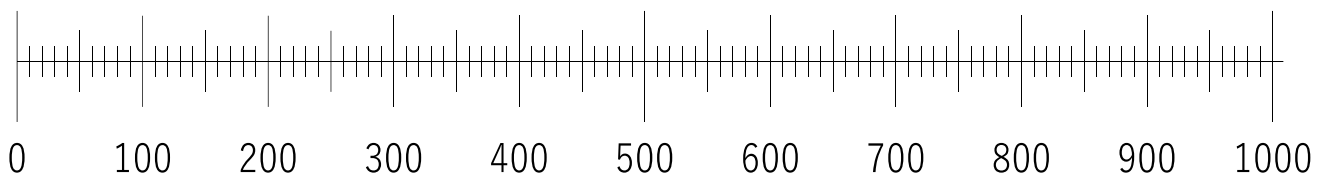

(Waziba bwanji?)

Extra

C









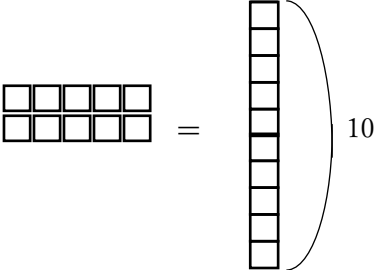
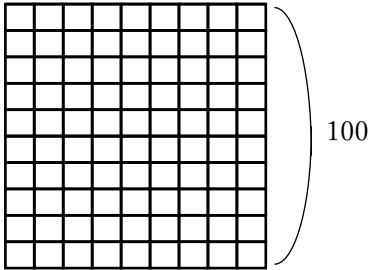
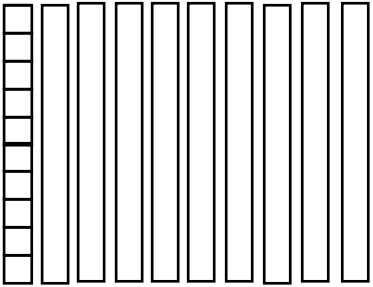
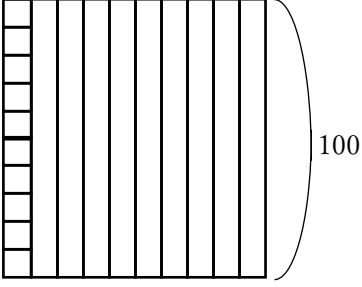

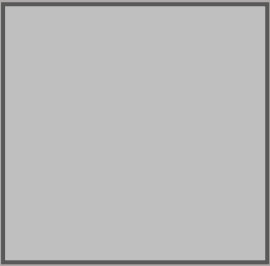
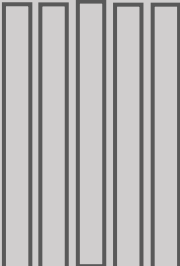

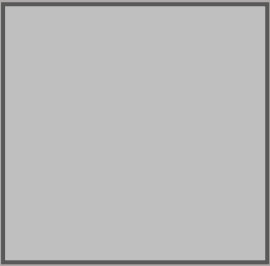
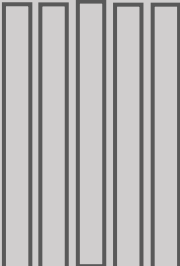
Ma namba tingayaonese bwanji kusebenzesa ma tile?

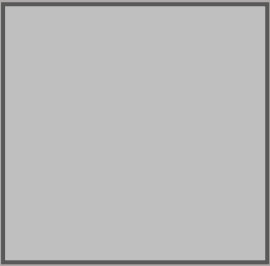
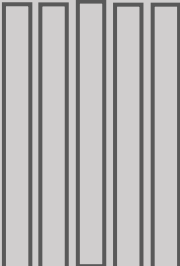
Date

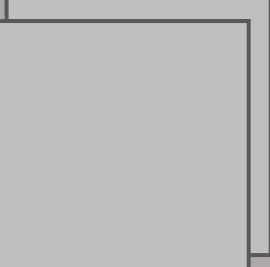
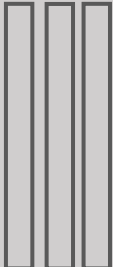
/ 2 Points

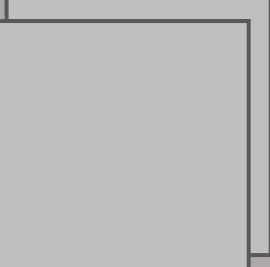
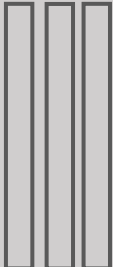
Tipunzile ma namba kusebenseza ma tiles.

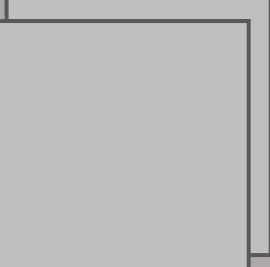
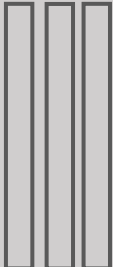
<p>Tuma 1 tuli 10 tupanga 10 imozi.</p> 	<p>Tuma 1 tuli 100 tupanga 100 imozi.</p> 	<p>-note- Kangono <input type="checkbox"/> katantauza 1 Katali <input type="checkbox"/> katantauza 10 Kakulu <input type="checkbox"/> katantauza 100</p>
<p>Ma ten yali 10 yapanga 100 imozi.</p> 		

<p>① Ma tiles aya yatantauza namba bwanji?</p> <table border="1" data-bbox="159 1081 1134 1435"> <thead> <tr> <th>Hundreds (100s)</th> <th>Tens (10s)</th> <th>Ones(1s)</th> </tr> </thead> <tbody> <tr> <td></td> <td></td> <td></td> </tr> </tbody> </table> <p style="text-align: right;">Ansa [154]</p>	Hundreds (100s)	Tens (10s)	Ones(1s)				<p><input type="checkbox"/> Nasiliza!</p>
Hundreds (100s)	Tens (10s)	Ones(1s)					
							
<p>② Ma tiles aya yatantauza namba bwanji?</p> <table border="1" data-bbox="159 1585 1114 1951"> <thead> <tr> <th>Hundreds (100s)</th> <th>Tens (10s)</th> <th>Ones(1s)</th> </tr> </thead> <tbody> <tr> <td></td> <td></td> <td></td> </tr> </tbody> </table> <p style="text-align: right;">Ansa []</p>	Hundreds (100s)	Tens (10s)	Ones(1s)				<p><input type="checkbox"/> Nasiliza!</p>
Hundreds (100s)	Tens (10s)	Ones(1s)					
							

D Yesa ku drawing'a ma tiles.

Tiyeni tichite practice ku drawing'a ma tiles yali mu exercise kuchoka pa ① kufika pa ③. Drawing'a ma tiles kuonesa ma namba yali mu exercise kuchoka pa ④ kufika pa ⑦.

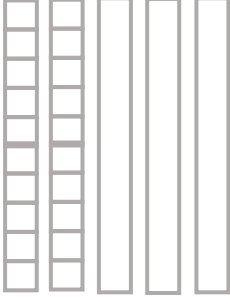
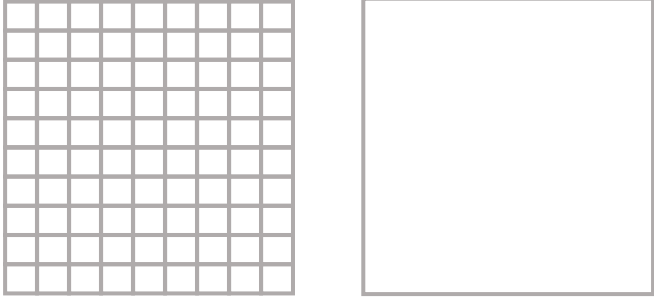
<p>① Yesa ku drawing'a tuma one utu tubwele 15 times</p> 	<p><input type="checkbox"/> Nasiliza!</p>
<p>② Yesa ku drawing'a tuma tens utu tubwele 15 times</p> 	<p><input type="checkbox"/> Nasiliza!</p>
<p>③ Yesa ku drawing'a tuma hundred utu tubwele 4 times</p> 	<p><input type="checkbox"/> Nasiliza!</p>

Pitiliza kufika pa page yamene ibwela.

Kupitiliza kuchoka ku page yamene yapita. Onesa mwamene waipezela.

④ $200 + 10 + 3 = 213$

Hundreds (100s)	Tens (10s)	Ones(1s)

Nasiliza!

⑤ $100 + 40 + 2 = 142$

Hundreds (100s)	Tens (10s)	Ones(1s)

Nasiliza!

⑥ $200 + 10 + 6 = 216$

Hundreds (100s)	Tens (10s)	Ones(1s)

Nasiliza!

⑦ $200 + 60 + 3 = 263$

Hundreds (100s)	Tens (10s)	Ones(1s)

Nasiliza!

II . Kulinganiza

Bushe waziba kuonesha ma namba kusebenzesa
ma tiles?
Manje tiyeni tiyalinganize!

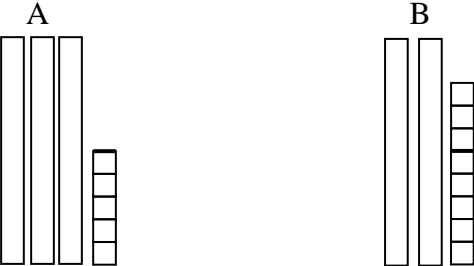
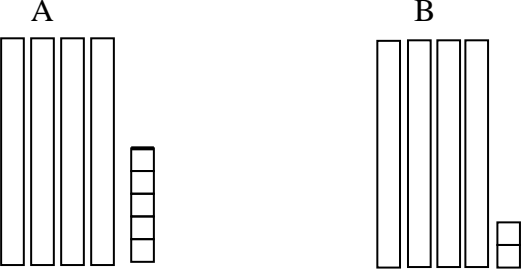
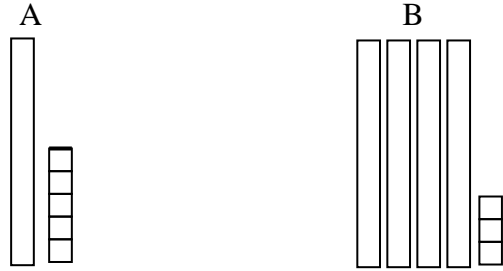

E Niyiti ikulu kusebenzesa ma tiles?

<p>① Sekoling'a ikulu, A olo B.</p> 	<p><input type="checkbox"/> Nasiliza!</p>
<p>② Sekoling'a ikulu, A olo B.</p> 	<p><input type="checkbox"/> Nasiliza!</p>
<p>③ Sekoling'a ikulu, A olo B.</p>  <p>(Waziba bwanji?) Walinganiza na tile iti, itali olo ing'ono?</p> <p style="text-align: right;">Ansa [_____]</p>	<p><input type="checkbox"/> Nasiliza!</p>
<p>④ Sekoling'a ikulu, A olo B.</p>  <p>(Waziba bwanji?)</p>	<p><input type="checkbox"/> Nasiliza!</p>

①

(1) Sekoling'a ikulu, A olo B.

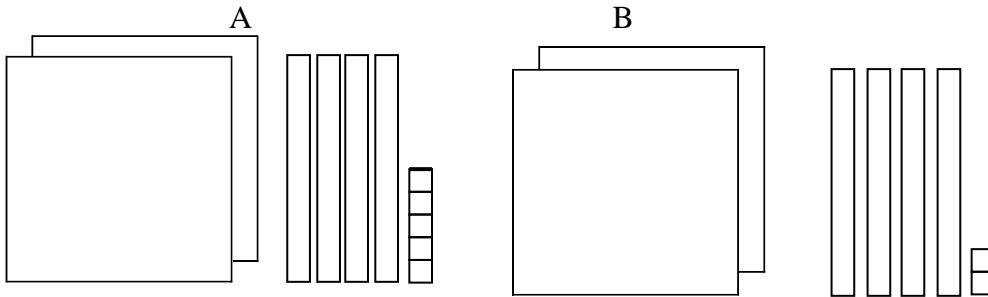

(Waziba bwanji?)

(2) Walinganiza na tile iti, ikulu, itali olo ing'ono?

Ansa [_____]

②

Sekoling'a ikulu, A olo B.

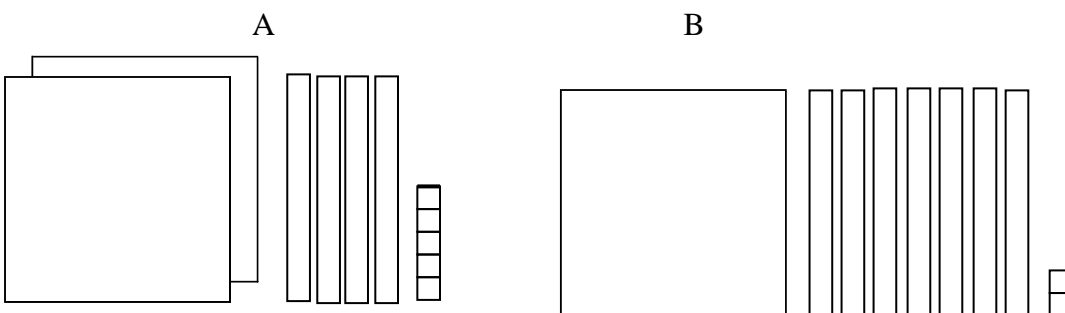

(Waziba bwanji?)

① Niyiti namba ikulu, 24 olo 29?

(Waziba bwanji?)

	Tens (10s)	Ones (1s)
24	2	4
29	2	9

Niyati ma place value yamene walinganiza, pali ma **Tens** na ma **Ones**?

Ansa [_____]

Niyiti namba ikulu, **24** olo **29**?

Ansa [_____]

Nasiliza!

② Niyiti namba ikulu, 73 olo 48?

(Waziba bwanji?)

	Tens (10s)	Ones (1s)
73	7	3
48	4	8

Niyati ma place value yamene walinganiza, pali ma **Tens** na ma **Ones**?

Ansa [_____]

Niyiti namba ikulu, **73** olo **48**?

Ansa [_____]

Nasiliza!

③ Niyiti namba ikulu, **84** olo **86**?

(Waziba bwanji?)

Ansa [_____]

Nasiliza!

④ Niyiti namba ikulu, **59** olo **65**?

(Waziba bwanji?)

Ansa [_____]

Nasiliza!

① Niyiti namba ikulu, 321 olo 325?

(1)

321 ilina [] muma hundreds, [] muma tens, na [] muma ones.

325 ilina [] muma hundreds, [] muma tens, na [] muma ones.

	Hundreds (100s)	Tens (10s)	Ones (1s)
321	3		
325			

(Waziba bwanji?)

(2) Niyati ma place value yamene walinganisa, pali ma **hundreds**, ma **tens**, na ma **ones**.

Ansa []

(3) Niyiti namba ikulu, 321 olo 325?

Ansa []

② Niyiti namba ikulu, 521 olo 359?

(1) Ma hundreds ma tens nama ones yaliyangati muma namba aya?

	Hundreds (100s)	Tens (10s)	Ones (1s)
521			
359			

(Waziba bwanji?)

Ansa []

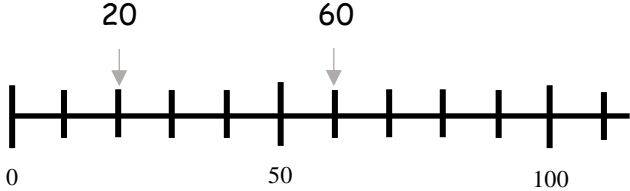
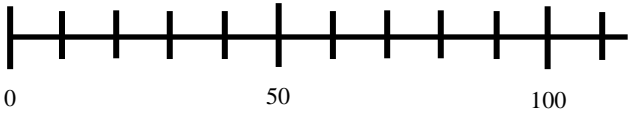
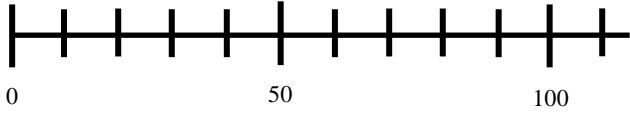
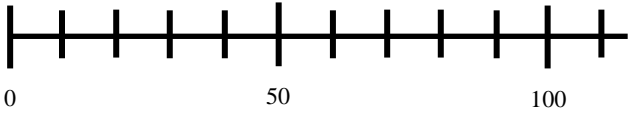
<p>① Niyiti namba ikulu, 20 olo 60? Onesa ma namba, 20 na 60 kusebenzesa tuma arrow.</p>  <p>(Waziba bwanji?) 60 iliku <u>right</u> kwa 20, ndiye kuti 60 ni <u>ikulu</u> pali 20.</p>	<input type="checkbox"/> Nasiliza!
<p>② Niyiti namba ikulu, 60 olo 90? Onesa ma namba, 60 na 90 kusebenzesa tuma arrow.</p>  <p>(Waziba bwanji?) 90 iliku <u> </u> kwa 60, ndiye kuti 90 ni <u> </u> pali 60.</p>	<input type="checkbox"/> Nasiliza!
<p>③ Niyiti namba ikulu, 110 olo 40? Onesa ma namba, 110 na 40 kusebenzesa tuma arrow.</p>  <p>(Waziba bwanji?) 110 iliku <u> </u> kwa 40, ndiye kuti 110 ni <u> </u> pali 40.</p>	<input type="checkbox"/> Nasiliza!
<p>④ Niyiti namba ikulu, 110 olo 60? Onesa ma namba, 110 na 60 kusebenzesa tuma arrow.</p>  <p>(Waziba bwanji?)</p>	<input type="checkbox"/> Nasiliza!

① Niyiti namba ikulu, 380 olo 310?

(1) Onetsa ma namba 380 na 310 kusebenzesa tuma arrow.

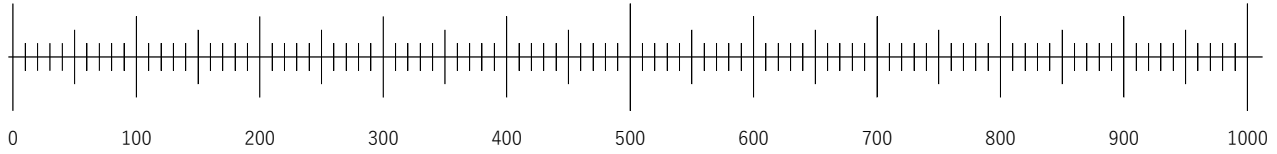

(Waziba bwanji?)

380 iliku [right] kwa 310, ndiye kuti 380 ni [ikulu] pali 310.

(2) Niyiti namba ikulu?

Ansa [_____]

② Niyiti namba ikulu, 810 olo 260?

(1) Onesa ma namba 810 na 260 kusebenzesa ma arrow.

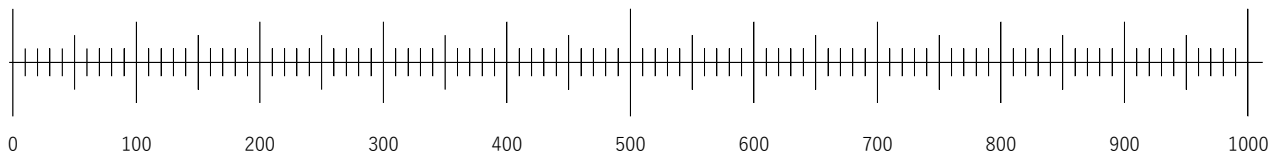

(Waziba bwanji?)

Ansa [_____]

III. Kupeza masamu

Chomaliza tizapeza ma ansa ya ma samu.
Tizaphunzila ma sainsi ya muma samu chamene
yatantauza.



Taphunzila kuti katantauza 1,

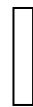

katantauza 10 elo



katantauza 100 polangiza.

Tiyeni titusebenzese kupeza ma samu!





Aka ka sign (+) katantauza chani?

Kuli ma eggs yali 30, ba Mr. Banda baleta ma eggs yali 12. Kuli ma eggs yangati pamodzi?

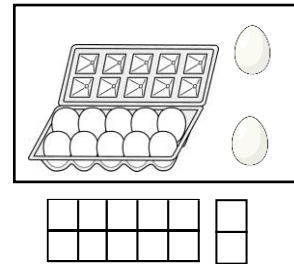
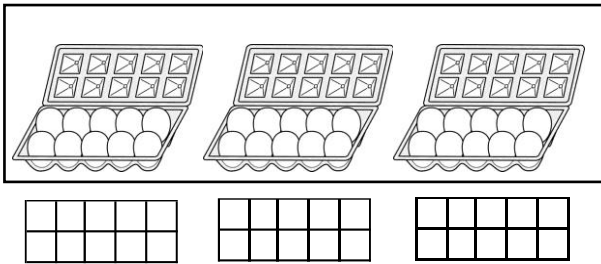

Tingaionese na sentence ya masamu iyi.

$$30 + 12 = 42$$

- ① Nili na ma tiles yali 245
Muzanga ali na ma tiles yali 122.
Tili na ma tiles yangati pamodzi?

Onesa mwamene waipezela.

Nasiliza!

Ngati katantauza 1,

katantauza 10

katantauza 100



Aka ka sign (-) katantauza chani?

Kuli ma egg yali 20, ba Mr. Banda banagula yali 14.
Kunasala ma eggs yangati?

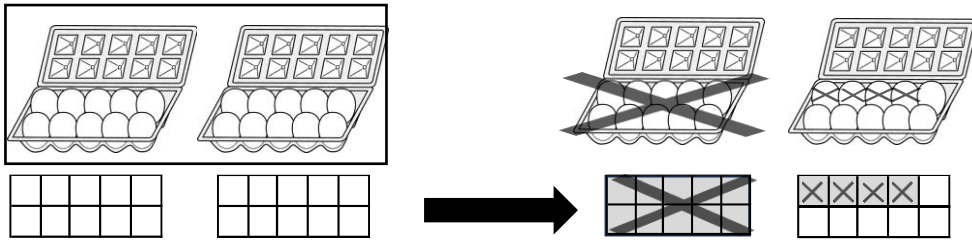

Tingaionese na sentence ya masamu iyi.

$$20 - 14 = 6$$

- ① Nili na ma tiles yali 235.
Nina pasa muzanga yali 124.
Nili na ma tiles yangati?

Onesa mwamene waipezela.

Nasiliza!

① $122+121=$

	1	2	2
+	1	2	1
	2	4	3



Peza kuyambila ku right.

② $321+120=$

	3	2	1
+	1	2	0

③ $157+422=$

	1	5	7
+	4	2	2

④ $222+314=$

	2	2	2
+	3	1	4

⑤ $348+213=$

	3	4	8
+	2	1	3
	5	6	1



Peza kuyambila ku right.

⑥ $129+314=$

	1	2	9
+	3	1	4

⑦ $274+143=$

	2	7	4
+	1	4	3

⑧ $178+122=$

	1	7	8
+	1	2	2

① $243 - 121 =$

—	2	4	3
	1	2	1
	1	2	2

Peza kuyambila ku right.

② $379 - 143 =$

—	3	7	9
	1	4	3

③ $368 - 125 =$

—	3	6	8
	1	2	5

④ $444 - 102 =$

—	4	4	4
	1	0	2

⑤ $561 - 348 =$

	5	10	
—	5	6	1
	3	4	8
	2	1	3

Peza kuyambila ku right.

⑥ $671 - 125 =$

—	6	7	1
	1	2	5

⑦ $360 - 126 =$

—	3	6	0
	1	2	6

⑧ $207 - 123 =$

—	2	0	7
	1	2	3



Aka ka sign(x) katantauza chani?

Pa mbale iliyonse pali ma banana yatatu; kuti kuli ma mbale yali 5, pali ma banana yali 15.

Uli na ma banana yangati?

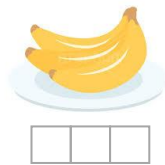
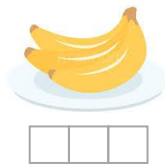
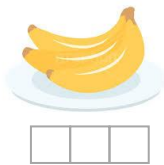
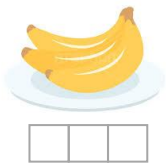

ingaionese na sentence ya masamu iyi.

$$3 + 3 + 3 + 3 + 3 = 15$$

Ma gulu yali 5 yama banana yatatu

$$5 \times 3 = 15$$

Namba ya
ma gulu

Namba mugulu
imodzi

Niyangati
pamodzi

① Kuli ma gulu yatatu, yama tiles yali 120.

Yali yangati yonse pamozi?

Onesa mwamene waipezela.

Nasiliza!

Mumalo yo onesa sentence ya times iyi, ungaonesa bwanji kuti inkale sentence ya plus?

$$\textcircled{1} \quad 4 \times 210 = 210 + 210 + 210 + 210$$

$$\textcircled{2} \quad 2 \times 420 =$$

Mumalo yo onesa sentence ya plus iyi, ungaonesa bwanji kuti inkale sentence ya times?

$$\textcircled{3} \quad 310 + 310 + 310 =$$

$$\textcircled{4} \quad 130 + 130 + 130 + 130 =$$



Aka ka sign (\div) katantauza chani?

Kuli ma banana yali 20. Tingabanisa bantu bali 5 molingana. Muntu umodzi anatenga ma banana angati?

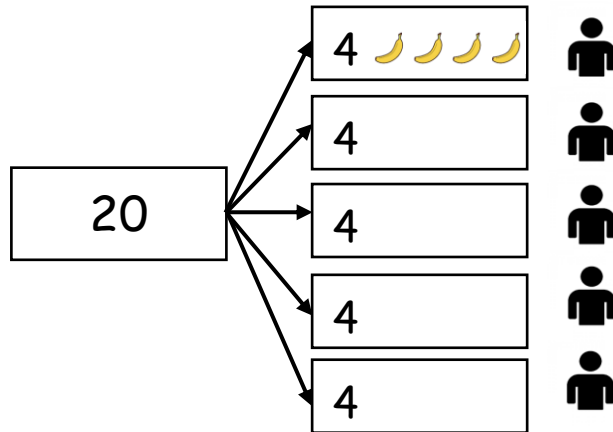
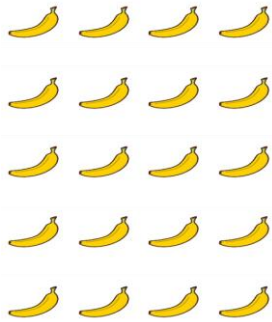

Tingaionese na sentence ya masamu iyi.

$$20 \div 5 = 4$$

20

Namba ya ma gulu

5

Namba ya ma gulu

4

Namba mugulu imodzi

① Pali ma tile 480. Tagabanisa bantu bali 4 molingana. Muntu umozi azankala na yangati ma tile?

Onesa mwamene waipezela.

Nasiliza!

Extra

L Ma samu ya divaidi by tichita bwanji? (2)

Date

/ 1 Points

Kuli ma sweet yali 360. Ngati bantu batatu bagabana molingana, muntu umodzi azatenga ma sweet angati?

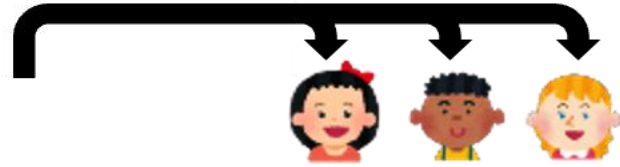

Onesa mwamene waipezela.

Kuli ma sweet yali 360. Ngati bantu batatu bagabana molingana, muntu umodzi azatenga ma sweet angati?

Arthur's idea



Ngati katantauza sweet umozi, katantauza 10 sweets, katantauza 100 sweets

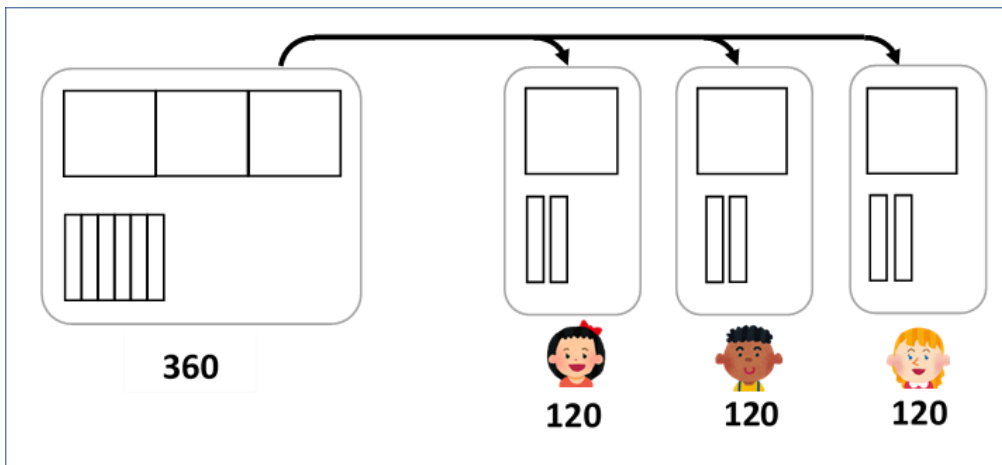

Mutinta's idea

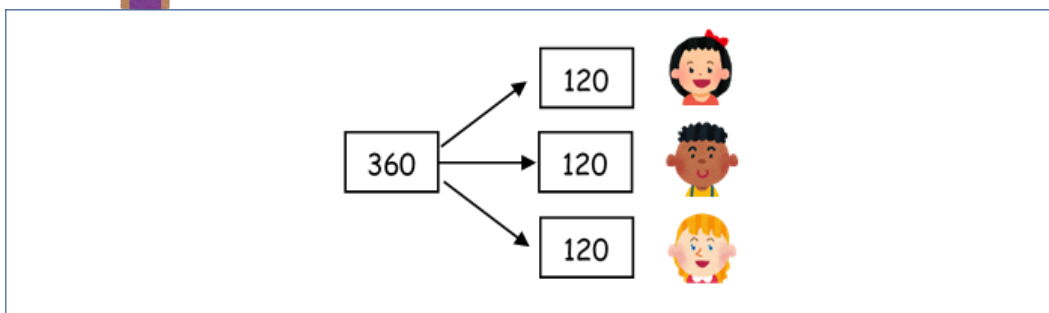

Niyangati pamodzi

Namba ya ma gulu

Namba mugulu imodzi

(Namba ya ma sweet pamodzi) ÷ (Namba ya bantu bazagabana) = (Namba ya ma sweet muntu umodzi azatenga)

$$\square \div \square = \square$$

Ansa: sweets

Peza division iyi.

① $240 \div 2 =$

Onesa mwamene waipezela.

② $360 \div 3 =$

Onesa mwamene waipezela.

③ $840 \div 4 =$

Onesa mwamene waipezela.

① $12 \times 3 =$

×	1	2
×	3	6



Peza kuyambila ku right.

② $21 \times 4 =$

×		
×		

③ $310 \times 3 =$

×	3	1	0
×	9	3	0



Peza kuyambila ku right.

④ $120 \times 2 =$

×			
×			

⑤ $212 \times 4 =$

×			
×			

⑥ $303 \times 2 =$

×			
×			

⑦ $150 \times 3 =$

×	1	5	0	100+50
×	1	5	0	50 × 3
+	3	0	0	100 × 3
	4	5	0	

⑧ $250 \times 3 =$

×			
×			

① $36 \div 3 =$

💡 Peza kuyambila ku left.

		1	2
	3	3	6
	—	3	↓
		0	6
	—		6
			0

② $48 \div 2 =$

)		
	—		
	—		

③ $484 \div 4 =$

💡 Peza kuyambila ku left.

	1	2	1
	4	8	4
	—	4	↓
		0	8
	—	8	8
		0	4
	—		4
			0

④ $336 \div 3 =$

)		
	—		
	—		

⑤ $260 \div 2 =$

)		
	—		
	—		

⑥ $804 \div 4 =$

)		
	—		
	—		

⑦ $270 \div 3 =$

💡 Peza kuyambila ku left.

	9	0	
	2	7	0
	—	2	7
			↓
			0
	—		0

⑧ $324 \div 4 =$

)		
	—		
	—		

Pupil's

Grade
5 & 6

Workbook

• Representing • Comparing • Calculating

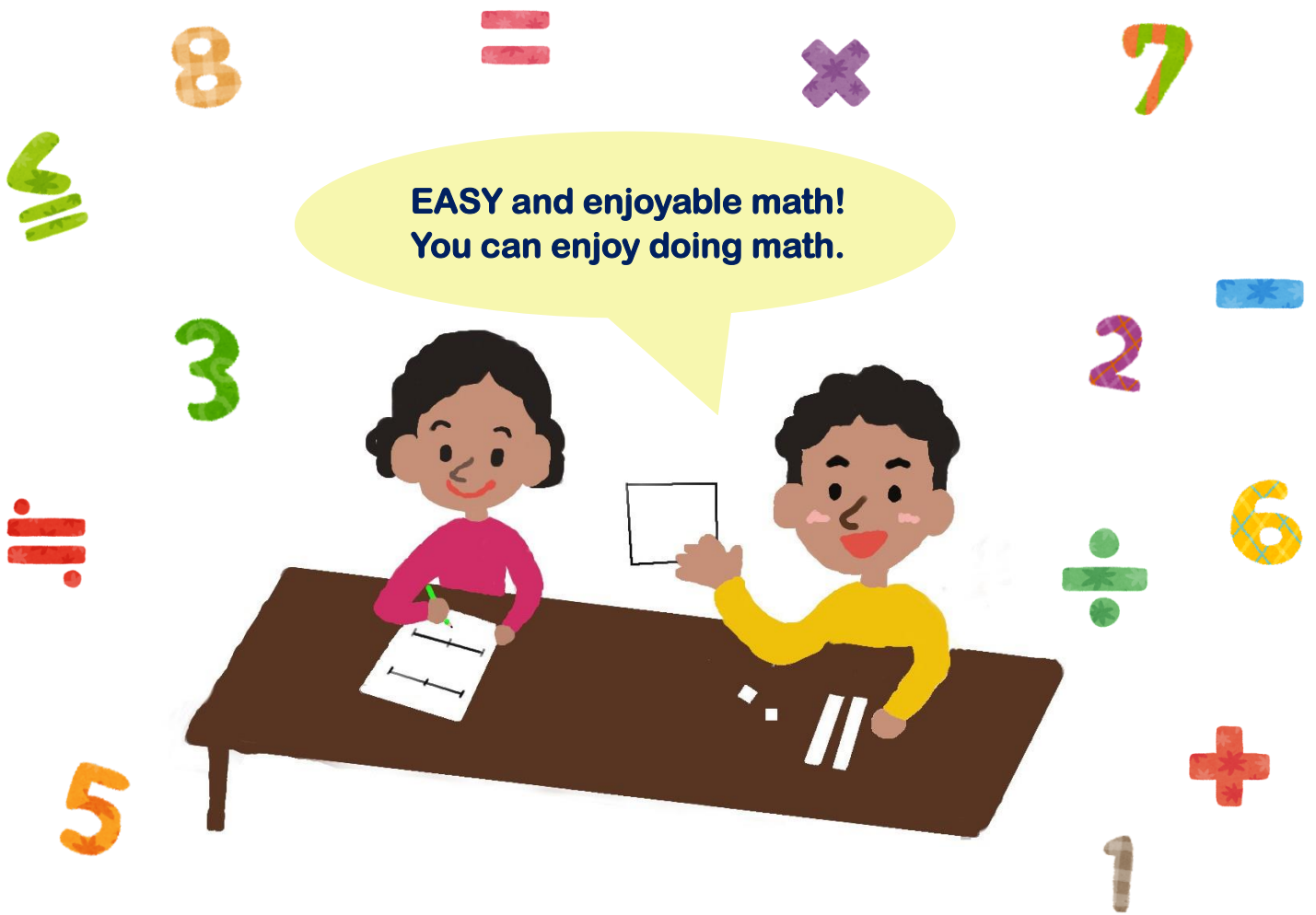

School: _____

Name: _____

Title: Pupils' workbook for Grade 5 & 6

Author: ABE, Yoshitaka

BABA, Takuya

CHIKOLA, Doye

KAABO, Emmanuel

KOSAKA, Masato

KUSAKA, Satoshi

MAMBWE, Bareford

MINAGOSHI, Kanae

MUDENDA, Barbara

MUNGALU, Arthur

NAKAWA, Nagisa

NALUBE, Patricia

NKHATA, Bentry

SIKWALE, Shelly

TAFENI, Spiwe

TAKUZWA, Jane, Njovu

WATANABE, Koji

YUDA, Shiori

Acknowledgment: The authors thank Professors Joanne Mulligan and Michael Mitchelmore, School of Education, Macquarie University, Sydney, Australia for their expert guidance and review of the document.

Copyright © 2024, All Rights Reserved

Progress check sheet

Name: _____

Date	Content
Example 30 March	Extra A
	Extra activity NA
	Practice N1
	Extra activity NB
	Practice N2
	Extra activity A
	Practice 1
	Practice 2
	Extra activity B
	Practice 3
	Practice 4
	Practice 5
	Extra activity C
	Extra activity D
	Extra activity E
	Practice 6
	Extra activity F
	Practice 7
	Extra activity G

Date	Content
	Practice 8
	Extra activity H
	Extra activity H'
	Extra activity I
	Extra activity I'
	Practice 9
	Practice 10
	Extra activity J
	Extra activity J'
	Practice 11
	Extra activity K
	Extra activity K'
	Practice 12
	Practice 13
	Practice 14

Content

I . Natural number representation.....	1
Extra activity NA; How do you represent the numbers using grids?.....	2
Practice N1; How do you represent the numbers using grids?.....	3
Extra activity NB; How do you represent the numbers using a number line?.....	4
Practice N2; How do you represent the numbers using a number line?.....	5
II. Decimal number representation	6
Extra activity A; How do you represent the numbers using grids?.....	7
Practice 1; How do you represent the numbers using grids?.....	8
Practice 2; How do you represent the numbers using grids?.....	9
Extra activity B; How do you represent the numbers using a number line?.....	10
Practice 3; How do you represent the numbers using a number line?.....	11
Practice 4; How do you represent the numbers using a number line?.....	12
Practice 5; How do you represent the numbers?: Connect different representations.....	13
Extra activity C; How do you represent numbers using tiles?.....	14
Extra activity D; Practice drawing the tiles.....	15

III. Comparison	17
Extra activity E; Which quantity is more using tiles?.....	18
Practice 6; Which quantity is more using tiles?.....	19
Extra activity F; Which quantity is bigger using numerals?.....	20
Practice 7; Which quantity is bigger using numerals?.....	21
Extra activity G; Which quantity is bigger using a number line?.....	22
Practice 8; Which quantity is bigger using a number line?.....	23
IV. Calculation	24
Extra activity H; How can you do addition?.....	25
Extra activity H'; How can you do addition?.....	26
Extra activity I; How can you do subtraction?.....	27
Extra activity I'; How can you do subtraction?.....	28
Practice 9; Column calculations for addition.....	29
Practice 10; Column calculations for subtraction.....	30
Extra activity J; How can you do multiplication?.....	31
Extra activity J'; How can you do multiplication?.....	32
Practice 11; How can you do multiplication?.....	33
Extra activity K; How can you do division?.....	34
Extra activity K'; How can you do division?.....	35
Practice 12; How can you do division?.....	37
Practice 13; Column calculations for multiplication.....	38
Practice 14; Column calculations for division.....	39

I . Natural Number representation

We review how to represent natural numbers.
Let's learn about various representations and
written explanations (reasons).

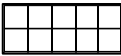

- ① If the whole of this grid  represents 10, what number does the shaded grid/box represent?



(Reason)

Answer [_____]

Done !

- ② If the whole of this grid  represents 100, what number do the shaded grids/boxes represent?

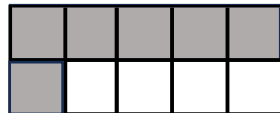

(Reason)

Answer [_____]

Done !

- ③ If the whole of this grid  represents 1000, what number do the shaded grids/boxes represent?

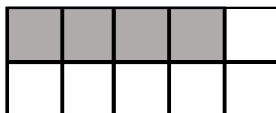

(Reason)

Answer [_____]

Done !

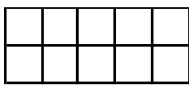
- ① If the whole of this grid  represents 100, what number is represented by the circled grids/boxes?

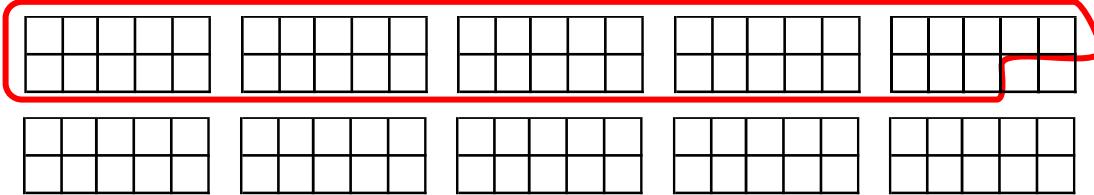

(Reason)

Answer [_____]

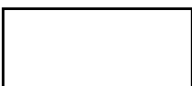
- ② If the whole of this grid  represents 100, circle 720 using the grids/boxes.

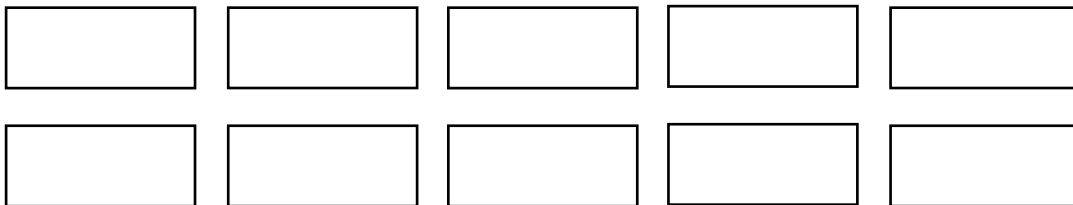

(Reason)

Extra
NB

How do you represent the numbers using
a number line?

Date

/ 3 Points

① Write the missing numbers in the boxes. Count each part from 0.

Done !

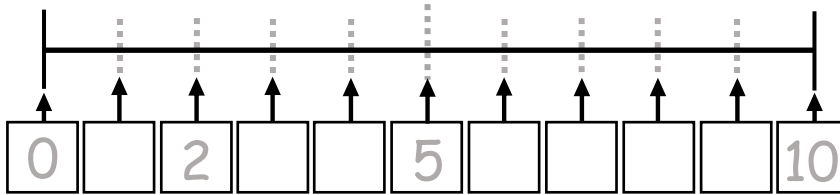

(Reason)

10 is on the 10th demarcation, so the 1st demarcation is _____.

② Write the missing numbers in the boxes. Count each part from 0.

Done !

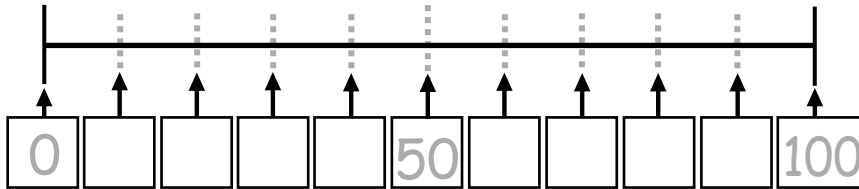

(Reason)

100 is on the 10th demarcation, so the 1st demarcation is _____.

③ Write the missing numbers in the boxes. Count each part from 0.

Done !

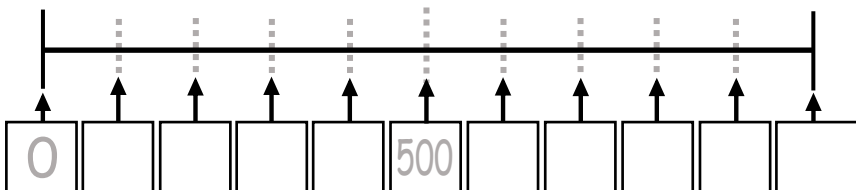

(Reason)

Practice
N2

How do you represent the numbers using a number line?

Date _____
/ 3 Points

① What number is indicated by the arrow on the number line?

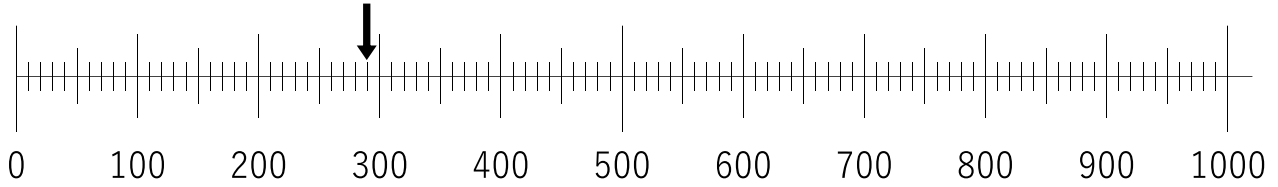

(Reason)

Answer [_____]

② Indicate the following numbers on the number lines with an arrow.

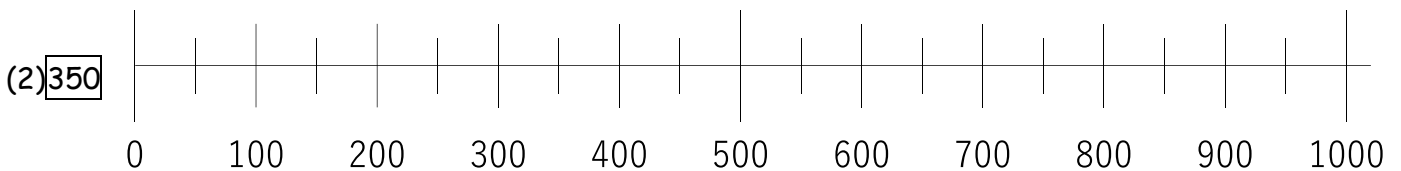
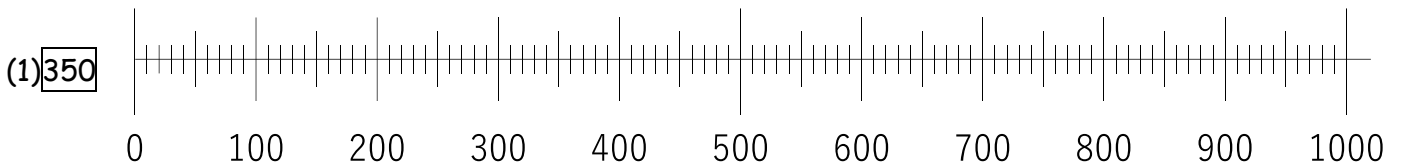







(Reason)

II . Decimal Number representation

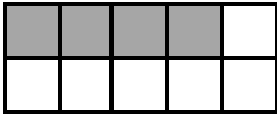

We learn how to represent decimal numbers!
Let's learn about various representations and
written explanations (reasons).

<p>① Divide the grid into 10 equal parts.</p> 	<input type="checkbox"/> Done !
<p>② Divide the grid into 10 equal parts.</p> 	<input type="checkbox"/> Done !
<p>③ Divide the grid into 10 equal parts.</p> 	<input type="checkbox"/> Done !
<p>④ If the whole of this grid  represents 1, what number do the shaded grids/ boxes represent?</p>  <p>(Reason)</p> <p style="text-align: right;"><u>Answer [_____]</u></p>	<input type="checkbox"/> Done !
<p>⑤ If the whole of this grid  represents 1, what number do the shaded grids/ boxes represent?</p>  <p>(Reason)</p> <p style="text-align: right;"><u>Answer [_____]</u></p>	<input type="checkbox"/> Done !

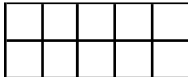
- ① If the whole of this grid  represents 1, what number is represented by the circled grids/boxes?

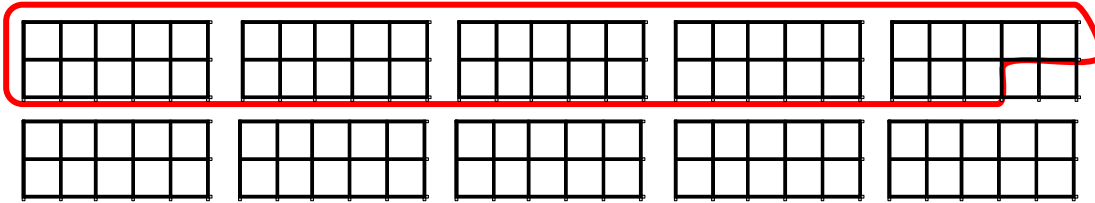

(Reason)

Answer [_____]

- ② If the whole of this grid  represents 1, what number is represented by the circled grids/boxes?

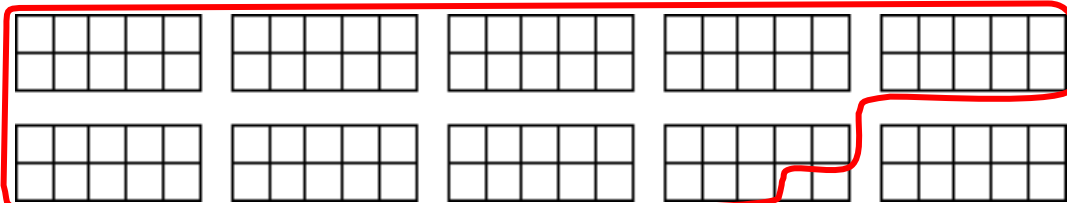

(Reason)

Answer [_____]

①

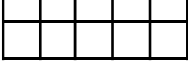
(1) If the whole of this grid  represents 1, circle 3.7 using the grids/boxes.

(Reason)

(2) If the whole of this grid  represents 1, circle 3.7 using the grids/boxes.

(Reason)

②

If the whole of this grid  represents 1, circle 7.2 using the grids/boxes.

(Reason)

Extra
B

How do you represent the numbers using a number line?

Date

/ 5 Points

- ① Divide the following into 10 equal parts. Count each part from 0.



Done !

- ② Cut in half, then divide into 10 equal parts. Count each part from 0.



Done !

- ③ Cut in half, then divide into 10 equal parts. Count each part from 0.

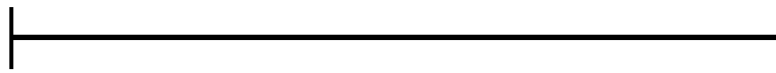

Done !

- ④ Write missing numbers in the boxes.

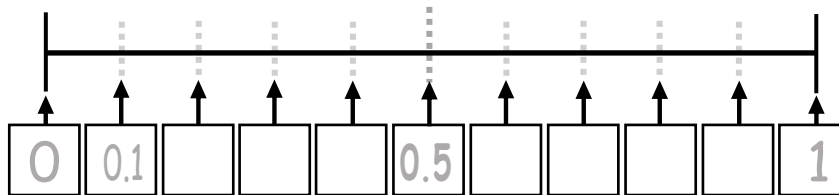

(Reason)

1 is on the 10th demarcation, so the 1st demarcation is _____.

Done !

- ⑤ Write the missing numbers in the boxes.

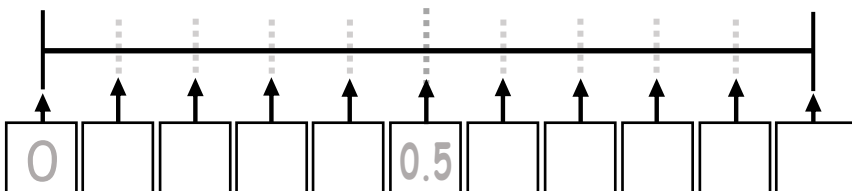

(Reason)

Done !

① What number is indicated by the arrow on the number line?

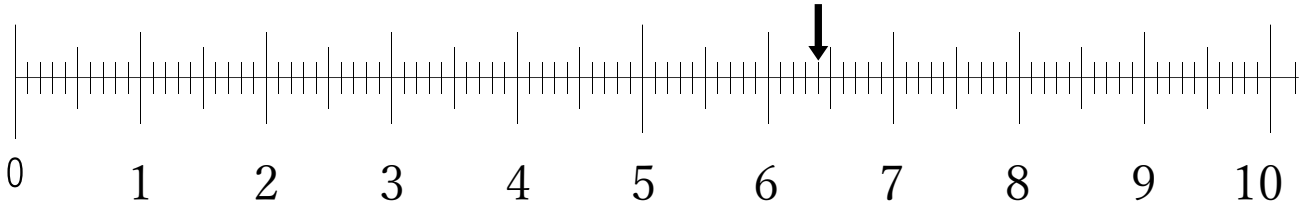

(Reason)

Answer [_____]

② What number is indicated by the arrow on the number line?

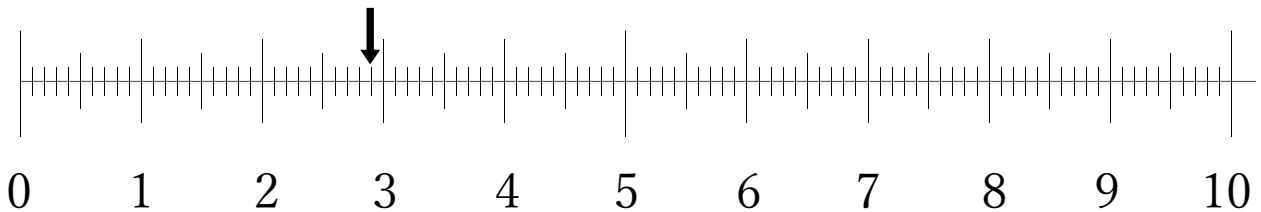

(Reason)

Answer [_____]

③ What number is indicated by the arrow on the number line?

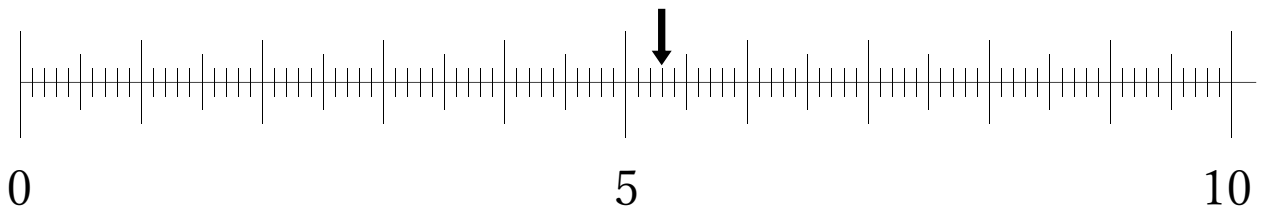

(Reason)

Answer [_____]

Indicate the following numbers on the number lines with an arrow.

①

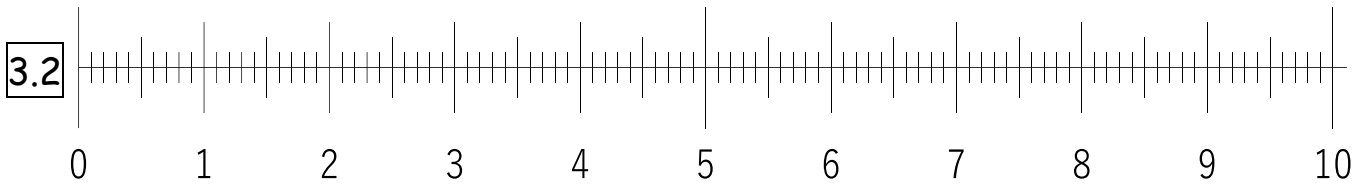

②

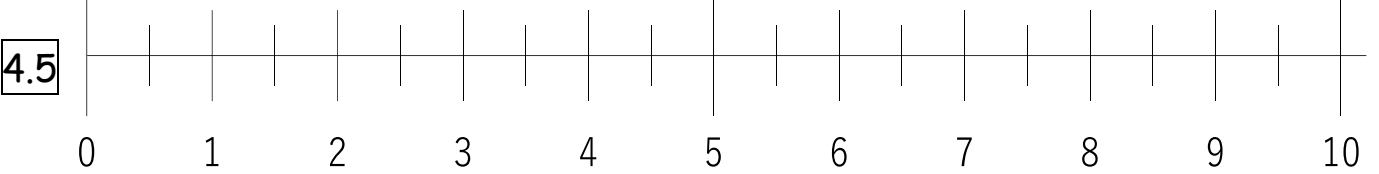

③

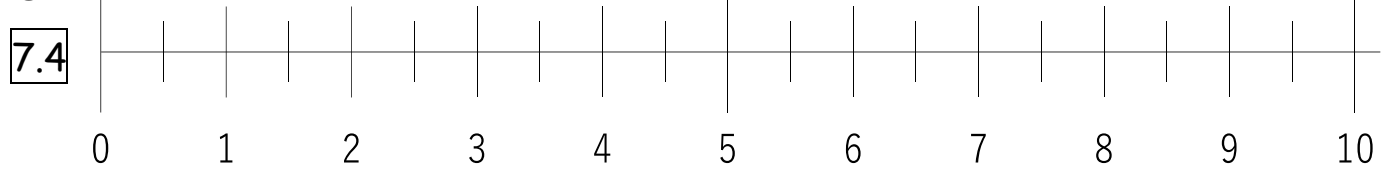

(Reason)

④

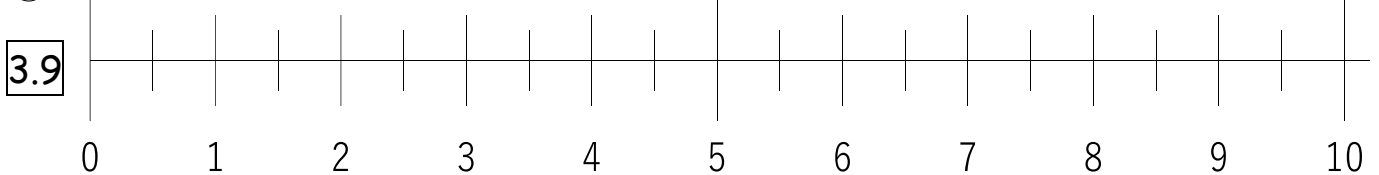

(Reason)

①

If the whole of this grid  represents 1, what number do the circled grids/ boxes represent?

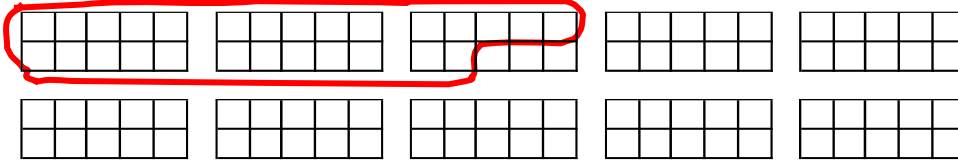

Indicate the above number on the number line with an arrow.

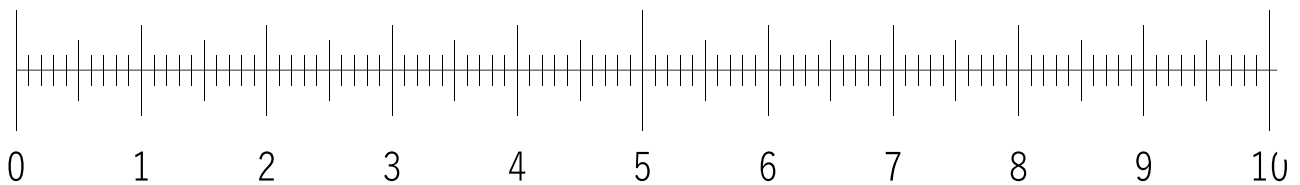

(Reason)

②

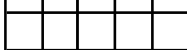
If the whole of this grid  represents 1, what number do the circled grids/ boxes represent?

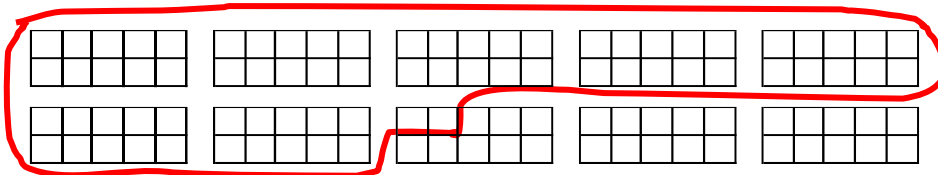



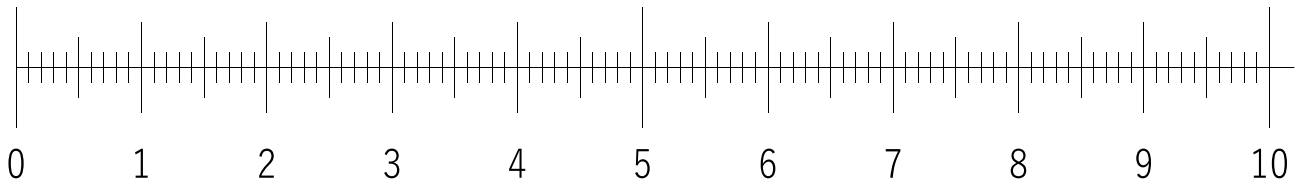





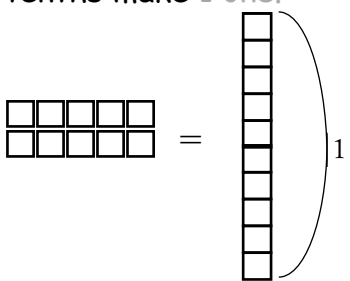
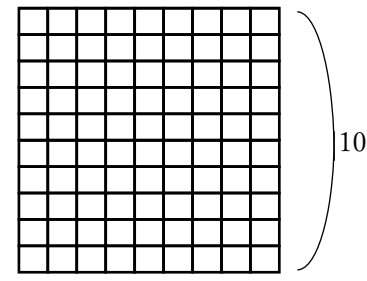
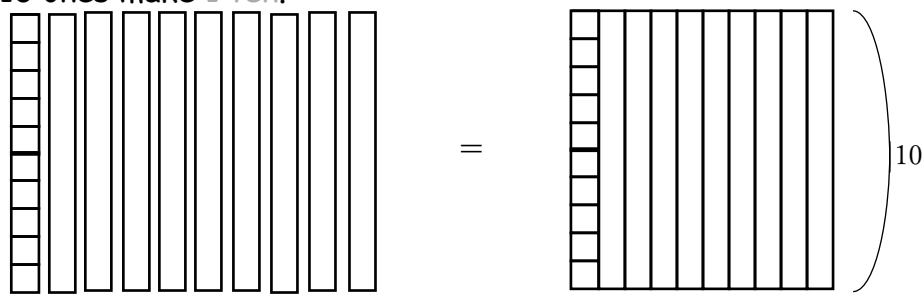

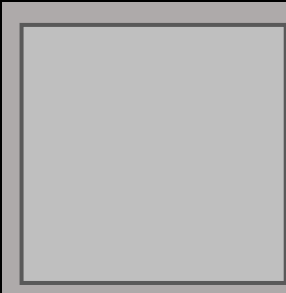
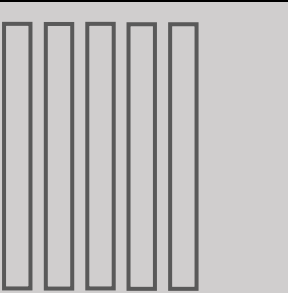

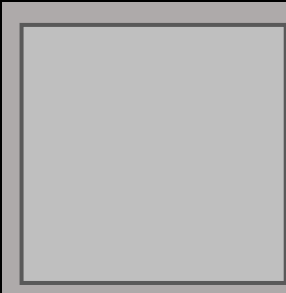
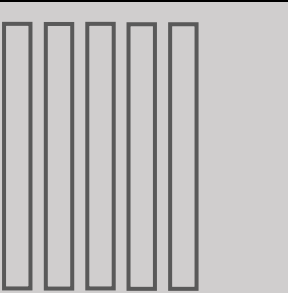
Indicate the above number on the number line with an arrow.

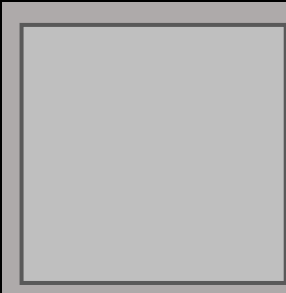
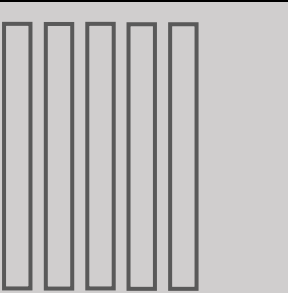

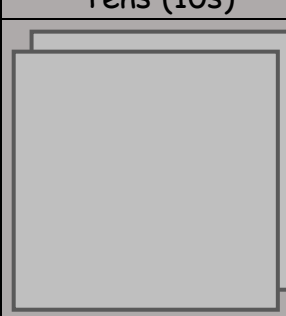
(Reason)

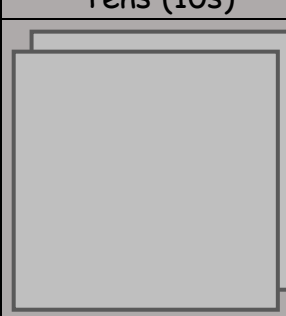
Let's learn number relationships using tiles.

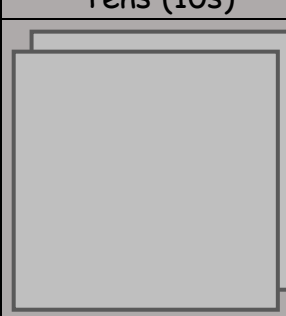
<p>10 tenths make 1 one.</p> 	<p>100 tenths make 1 ten.</p> 	<p>-note-</p> <p>A small tile <input type="checkbox"/> represents 0.1</p> <p>A long tile represents 1</p> <p>A large tile <input type="checkbox"/> represents 10</p>
<p>10 ones make 1 ten.</p> 		

<p>① What number is represented by the tiles?</p> <table border="1" style="width: 100%; border-collapse: collapse; text-align: center;"> <thead> <tr> <th style="width: 33%;">Tens (10s)</th> <th style="width: 33%;">Ones (1s)</th> <th style="width: 33%;">Tenths (0.1s)</th> </tr> </thead> <tbody> <tr> <td style="height: 150px;"></td> <td style="height: 150px;"></td> <td style="height: 150px;"></td> </tr> </tbody> </table> <p style="text-align: right; margin-top: 10px;">Answer [15.4]</p>	Tens (10s)	Ones (1s)	Tenths (0.1s)				<p><input type="checkbox"/> Done !</p>
Tens (10s)	Ones (1s)	Tenths (0.1s)					
							
<p>② What number is represented by the tiles?</p> <table border="1" style="width: 100%; border-collapse: collapse; text-align: center;"> <thead> <tr> <th style="width: 33%;">Tens (10s)</th> <th style="width: 33%;">Ones (1s)</th> <th style="width: 33%;">Tenths (0.1s)</th> </tr> </thead> <tbody> <tr> <td style="height: 150px;"></td> <td style="height: 150px;"></td> <td style="height: 150px;"></td> </tr> </tbody> </table> <p style="text-align: right; margin-top: 10px;">Answer [_____]</p>	Tens (10s)	Ones (1s)	Tenths (0.1s)				<p><input type="checkbox"/> Done !</p>
Tens (10s)	Ones (1s)	Tenths (0.1s)					
							

Let's practice drawing the frame of the tiles in exercises ① to ③.

Draw the tiles to represent the numbers in exercises ④ to ⑦.

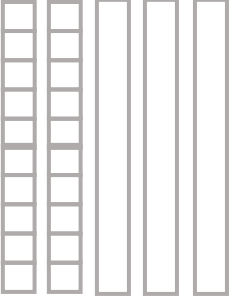
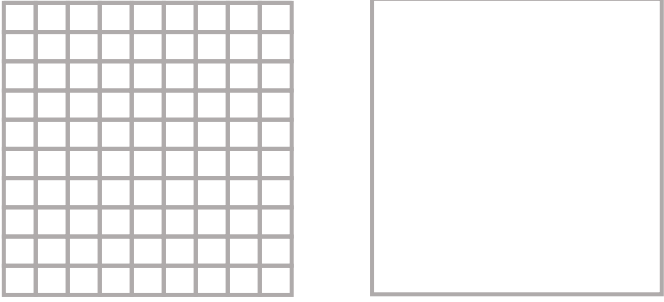
<p>① Tenths (practice 15 times)</p> 	<p><input type="checkbox"/> Done !</p>
<p>② Ones (practice 15 times)</p> 	<p><input type="checkbox"/> Done !</p>
<p>③ Tens (practice 4 times)</p> 	<p><input type="checkbox"/> Done !</p>

Continue to the next page.

Continuation of the previous page. Show your works.

④

$$20 + 1 + 0.4 = 21.4$$

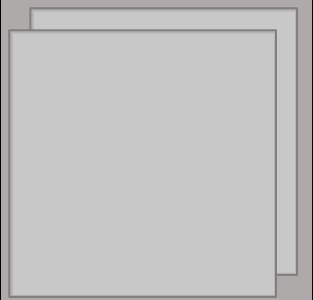
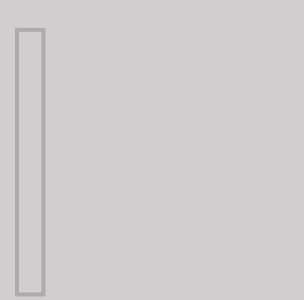
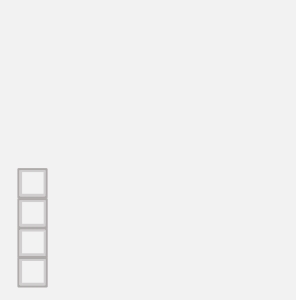
Tens (10s)	Ones (1s)	Tenths (0.1s)
		

Done !

⑤

$$10 + 2 + 0.3 = 12.3$$

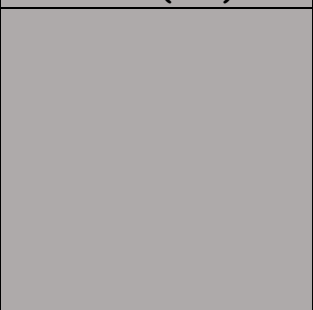
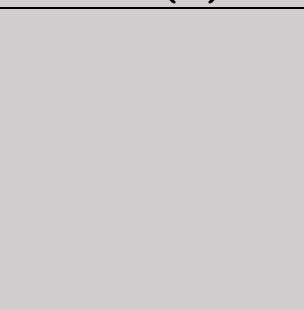
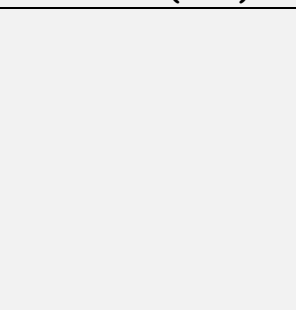
Tens (10s)	Ones (1s)	Tenths (0.1s)
		

Done !

⑥

$$10 + 4 + 0.2 = 14.2$$

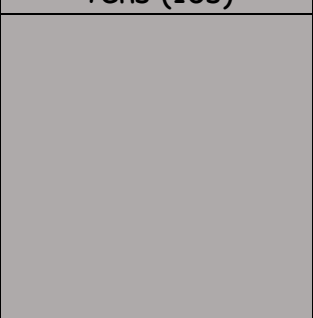
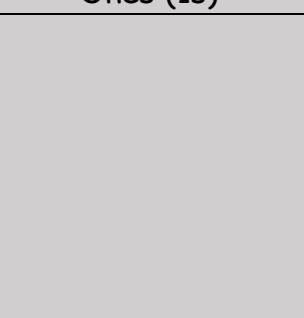
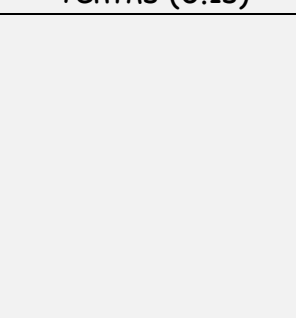
Tens (10s)	Ones (1s)	Tenths (0.1s)
		

Done !

⑦

$$20 + 1 + 0.6 = 21.6$$

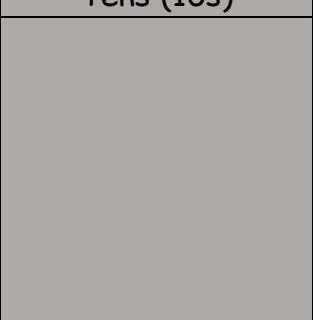
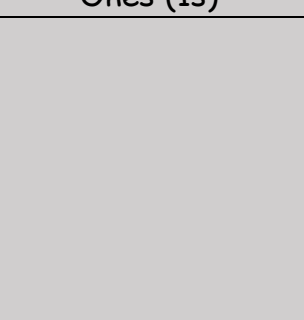
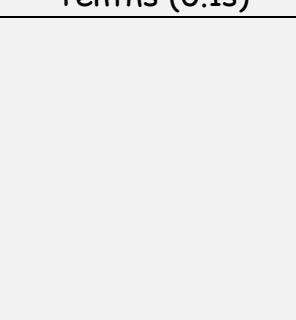
Tens (10s)	Ones (1s)	Tenths (0.1s)
		



Done !

III. Comparison

Have you mastered how to represent numbers?
Next, let's compare their sizes!

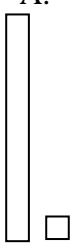
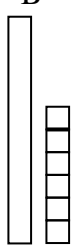
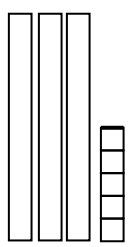
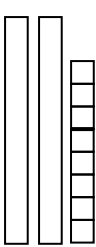
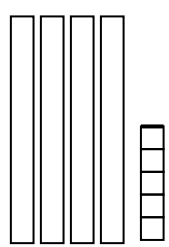
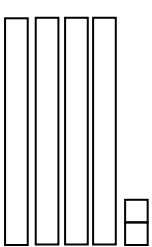

E Which quantity is bigger using tiles?

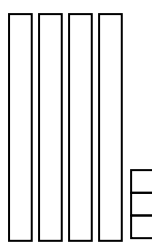
<p>① Which quantity is bigger, A or B? Circle A or B.</p> <div style="display: flex; justify-content: space-around; align-items: center;"> <div style="text-align: center;"> <p>A.</p>  </div> <div style="text-align: center;"> <p>B</p>  </div> </div>	<p><input type="checkbox"/> Done !</p>
<p>② Which quantity is bigger, A or B? Circle A or B.</p> <div style="display: flex; justify-content: space-around; align-items: center;"> <div style="text-align: center;"> <p>A.</p>  </div> <div style="text-align: center;"> <p>B</p>  </div> </div>	<p><input type="checkbox"/> Done !</p>
<p>③ Which quantity is bigger, A or B? Circle A or B.</p> <div style="display: flex; justify-content: space-around; align-items: center;"> <div style="text-align: center;"> <p>A.</p>  </div> <div style="text-align: center;"> <p>B</p>  </div> </div> <p>(Reason)</p> <p>Which tile did you use to compare, the long tile or the small tile?</p> <p style="text-align: right;">Answer[_____]</p>	<p><input type="checkbox"/> Done !</p>
<p>⑤ Which quantity is bigger, A or B? Circle A or B.</p> <div style="display: flex; justify-content: space-around; align-items: center;"> <div style="text-align: center;"> <p>A.</p>  </div> <div style="text-align: center;"> <p>B</p>  </div> </div> <p>(Reason)</p>	<p><input type="checkbox"/> Done !</p>

6 Which quantity is bigger using tiles?

①

(1) Which quantity is bigger, A or B? Circle A or B.

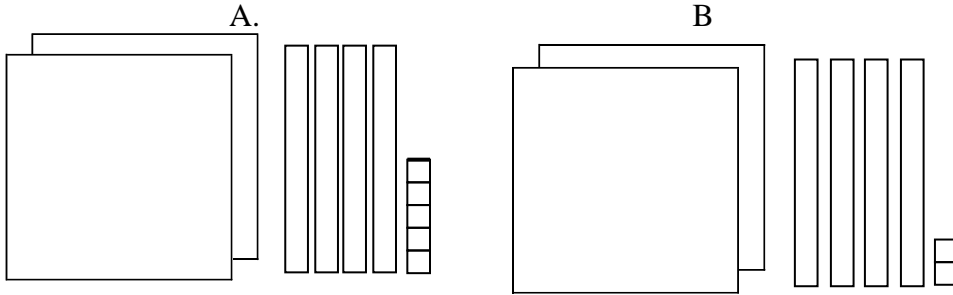

(Reason)

(2) Which tile did you use to compare, **the large tile**, **the long tile**, or **the small tile**?

Answer [_____]

② Which quantity is bigger, A or B? Circle A or B.

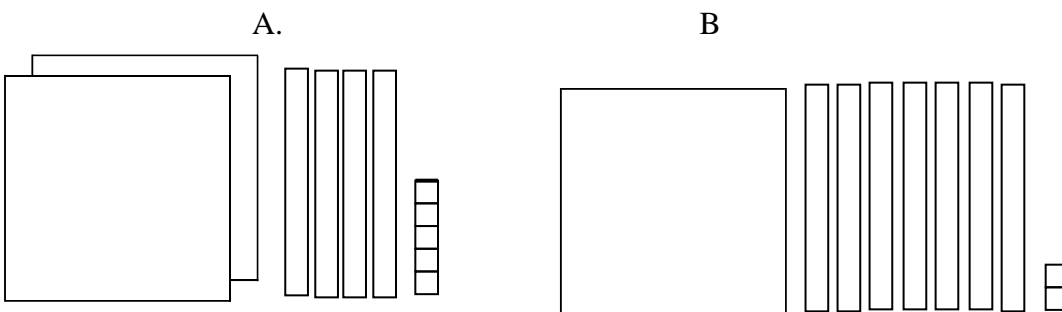

(Reason)

① Which quantity is bigger, 2.4 or 2.9?

(Reason)

	Ones (1s)	Tenths (0.1s)
2.4	2	. 4
2.9	2	. 9

Which place value did you compare, **Ones** or **Tenths**?

Answer [_____]

Which quantity is bigger, **2.4** or **2.9**?

Answer [_____]

Done !

② Which quantity is bigger, 7.3 or 4.8?

(Reason)

	Ones (1s)	Tenths (0.1s)
7.3	7	. 3
4.8	4	. 8

Which place value did you compare, **Ones** or **Tenths**?

Answer [_____]

Which quantity is bigger, **7.3** or **4.8**?

Answer [_____]

Done !

③ Which quantity is bigger, **8.4** or **8.6**?

(Reason)

Answer [_____]

Done !

④ Which quantity is bigger, **5.9** or **6.5**?

(Reason)

Answer [_____]

Done !

① Which quantity is bigger, 32.1 or 32.5?

(1)

32.1 has [] in the tens place, [] in the ones place, and [] in the tenths place.

32.5 has [] in the tens place, [] in the ones place, and [] in the tenths place.

	Tens (10s)	Ones (1s)	Tenths (0.1s)
32.1	3		
32.5			

(Reason)

(2) Which place value did you compare, **Tens**, **Ones** or **Tenths**?

Answer []

(3) Which quantity is bigger, **32.1** or **32.5**?

Answer []

② Which quantity is bigger, 52.1 or 35.9?

(1) What are the number of tens, ones, and tenths in each number?

	Tens (10s)	Ones (1s)	Tenths (0.1s)
52.1			
35.9			

(Reason)

Answer []

G Which quantity is bigger using a number line?

① Which quantity is bigger, 0.2 or 0.6?

Indicate the numbers, 0.2 and 0.6, with arrows.

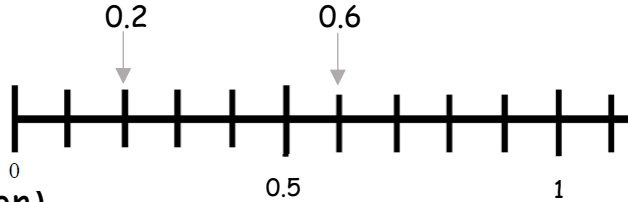

(Reason)

0.6 is to the right of 0.2, so 0.6 is bigger than 0.2.

Done !

② Which quantity is bigger, 0.6 or 0.9?

Indicate the numbers, 0.6 and 0.9, with arrows.

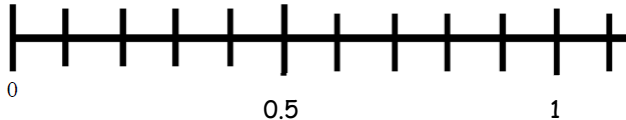

(Reason)

0.9 is to the of 0.6, so 0.9 is than 0.6.

Done !

③ Which quantity is bigger, 1.1 or 0.4?

Indicate the numbers, 1.1 and 0.4, with arrows.

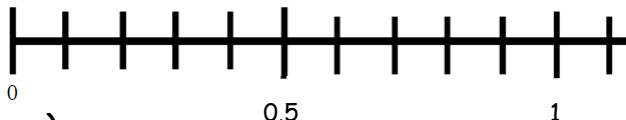

(Reason)

1.1 is to the of 0.4, so 1.1 is than 0.4.

Done !

④ Which quantity is bigger, 1.1 or 0.9?

Indicate the numbers, 1.1 and 0.9, with arrows.

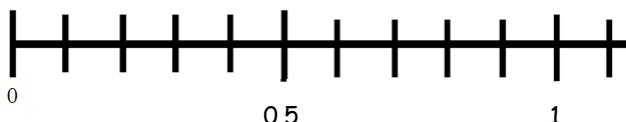

(Reason)

Done !

8 Which quantity is bigger on a number line?

① Which quantity is bigger, 3.8 or 3.1?

(1) On the number line, show the numbers, 3.8 and 3.1 with arrows.

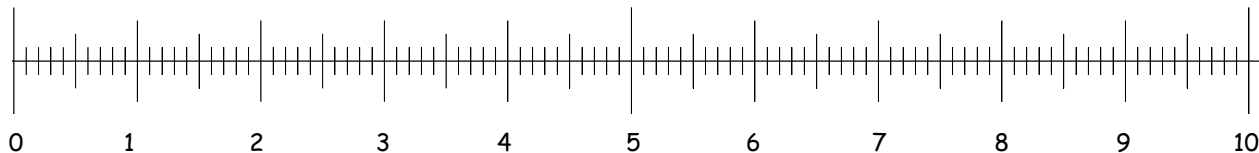

(Reason)

3.8 is to the [right] of 3.1, so 3.8 is [bigger] than 3.1.

(2) Which quantity is bigger?

Answer []

② Which quantity is bigger, 8.1 or 2.6?

(1) On the number line, show the numbers, 8.1 and 2.6 with arrows.

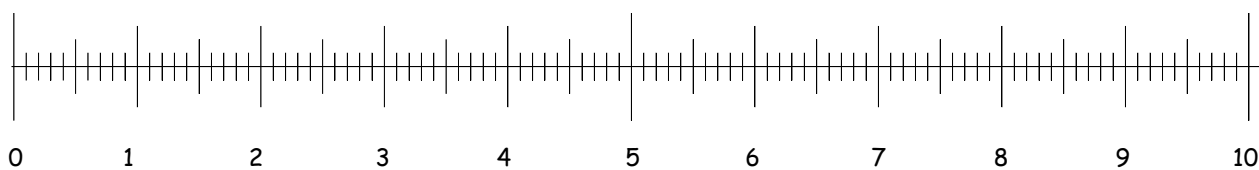

(Reason)

Answer []

IV. Calculation

The final part is calculation.

We learn the meaning of four fundamental operations in math.



We have learned to use tiles to represent numbers.
Try to use them during problem solving.



What does the calculation symbol (+) represent?

There are 30 eggs. Mr. Mike has brought 12 eggs.
How many eggs do you have in total?

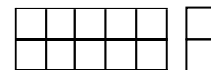
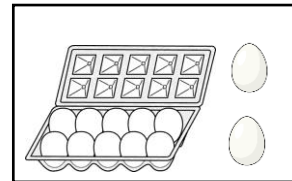
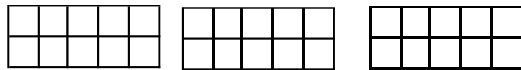
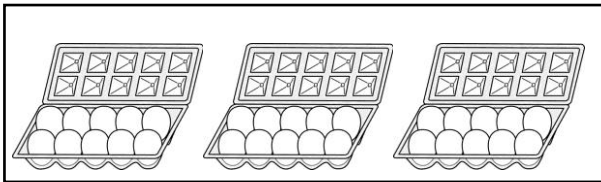

It is represented by the following math sentence.

$$30 + 12 = 42$$

- ① I have 245 tiles.
My friend has 122 tiles.
How many tiles do we have in total?

Show your work.

Done !

If represents 1,



represents 10

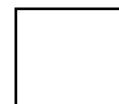

represents 100

Mr. Mike had 1.5 meters of chitenge.
 He bought another 1.3 meters of chitenge.
 How many meters of chitenge did he have?

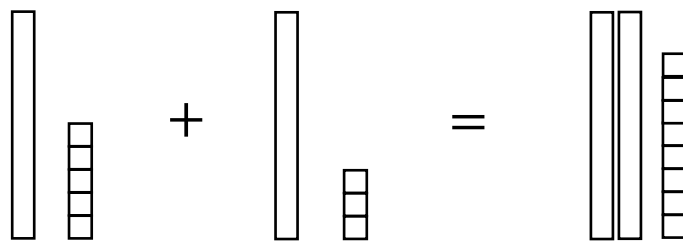
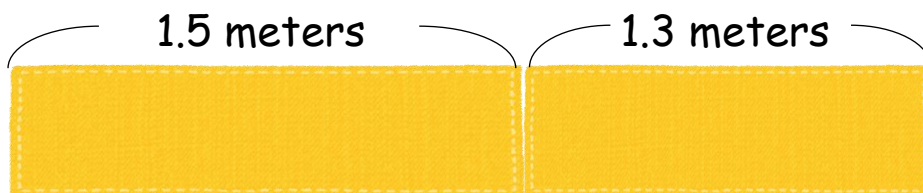

If represents 0.1,

represents 1

represents 10

It is represented by the following math sentence.

$$1.5 + 1.3 = 2.8$$

- ② I have 2.5 liters of water.
 My friend has 3.2 liters of water.
 How many liters of water do we have in total?

Show your work using tiles.

Done !



What does the calculation symbol (-) represent?

There are 20 eggs. Mr. Banda bought 14.
How many eggs are left?

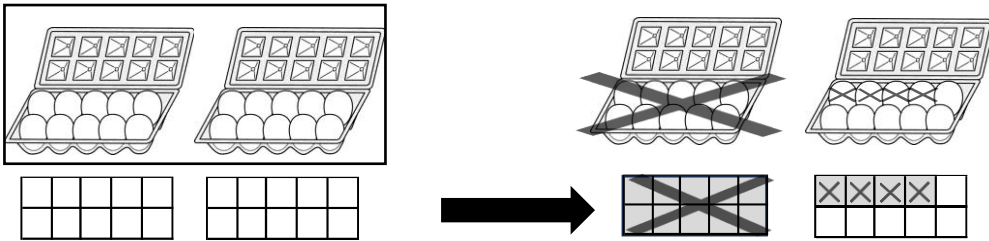

It is represented by the following math sentence.

$$20 - 14 = 6$$

- ① I have 235 tiles.
I gave 124 tiles to a friend.
How many tiles do I have?

Show your work.

Done !

If represents 1,

represents 10

represents 100

There are 2.8 meters of chitenge.
Ms. Luyando used 1.2 meters of chitenge.
How many meters of chitenge are left?

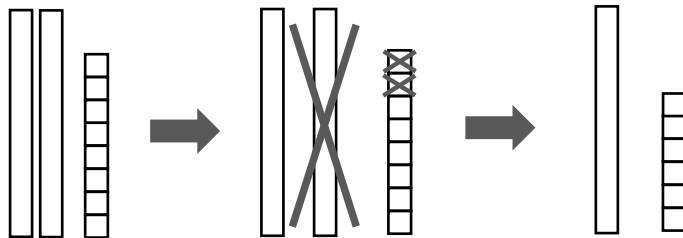
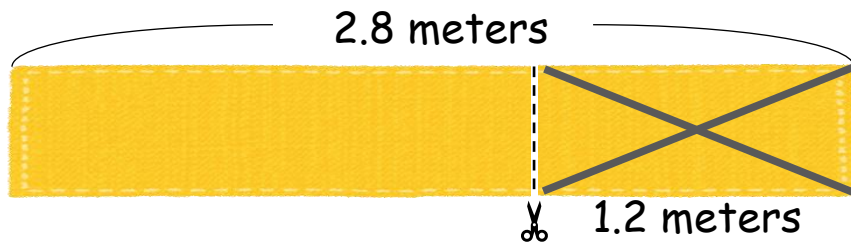

If represents 0.1,

represents 1

represents 10

It is represented by the following math sentence.

$$2.8 - 1.2 = 1.6$$

③ There are 3.9 liters of water.
I used 1.4 liters of water for cooking.
How many liters of water are left?

Show your work using tiles.

Done !

① $4.2+2.1=$

$$\begin{array}{r} 4.2 \\ + 2.1 \\ \hline \end{array}$$



Calculate from right.

② $0.4+0.5=$

$$\begin{array}{r} 0.4 \\ + 0.5 \\ \hline \end{array}$$

③ $32.1+14.2=$

$$\begin{array}{r} 32.1 \\ + 14.2 \\ \hline \end{array}$$

④ $22.2+1.4=$

$$\begin{array}{r} 22.2 \\ + 1.4 \\ \hline \end{array}$$

⑤ $34.8+21.3=$

$$\begin{array}{r} 34.8 \\ + 21.3 \\ \hline 56.1 \end{array}$$



Calculate from right.

⑥ $12.9+31.4=$

$$\begin{array}{r} 12.9 \\ + 31.4 \\ \hline \end{array}$$

⑦ $27.4+14.3=$

$$\begin{array}{r} 27.4 \\ + 14.3 \\ \hline \end{array}$$

⑧ $17.8+12.2=$

$$\begin{array}{r} 17.8 \\ + 12.2 \\ \hline \end{array}$$

① $6.3 - 4.2 =$



Calculate from right.

② $0.9 - 0.3 =$

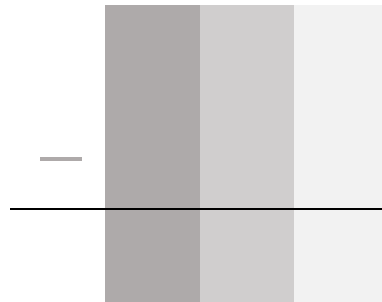

③ $36.2 - 12.1 =$

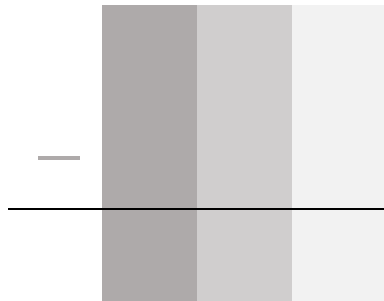

④ $44.4 - 11.2 =$

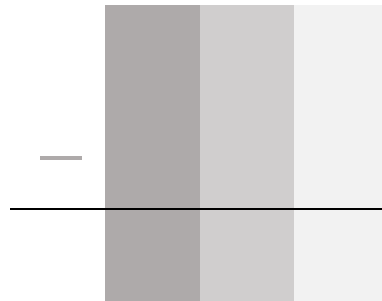

⑤ $56.1 - 34.8 =$

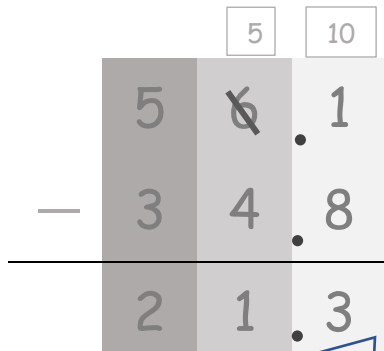

Calculate from right.

⑥ $67.1 - 12.5 =$

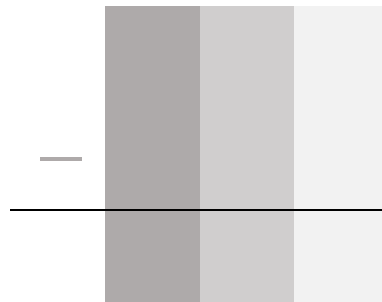

⑦ $32.8 - 14.6 =$



⑧ $20.6 - 12.3 =$





What does the calculation symbol (x) represent?

There are 3 bananas on each plate; since there are 5 plates, there are 15 bananas.

How many bananas do you have?



It is represented by the following math sentence.

$$3 + 3 + 3 + 3 + 3 = 15$$

5 groups of 3 bananas

$$5 \times 3 = 15$$

Number of
groups

Number in
one group.

Total
Number

① There are 3 groups of 120 tiles.

How much is it in total?

Show your work.

Done !

If represents 1,



represents 10

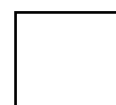

represents 100

A bottle of cooking oil contains 1.2 liters.

Ms. Jane bought 3 bottles of cooking oil.

How many liters of cooking oil does she have altogether?

1.2 Liter 1.2 Liter 1.2 Liter

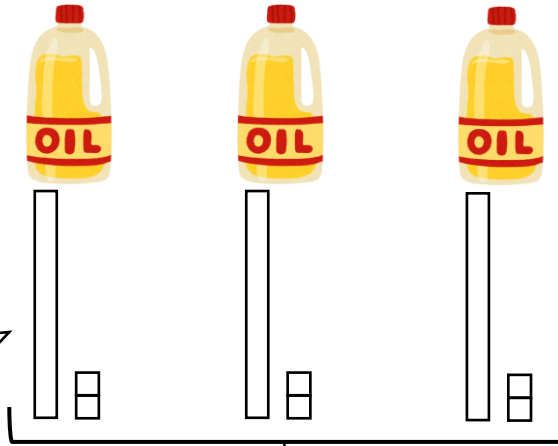

If represents 0.1,



represents 1



represents 0.1

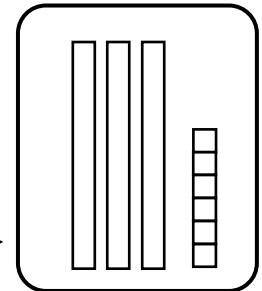

It is represented by the following math sentence.

$$3 \times 1.2 = 3.6$$

- ① There are 4 packets of sugar.
Each packet has 2.1 kilograms of sugar.
How many kilograms of sugar are there in total?
Show your work using tiles.

Done !

How do you show a math sentence using addition instead of the following multiplication?

① $4 \times 2.1 = 2.1 + 2.1 + 2.1 + 2.1$

② $3 \times 3.2 =$

How do you show a math sentence using multiplication instead of the following addition?

③ $3.1 + 3.1 + 3.1 =$

④ $1.3 + 1.3 + 1.3 + 1.3 =$



What does the calculation symbols (\div) represent?

There are 20 bananas. We share among 5 people.
How many bananas does one person have?

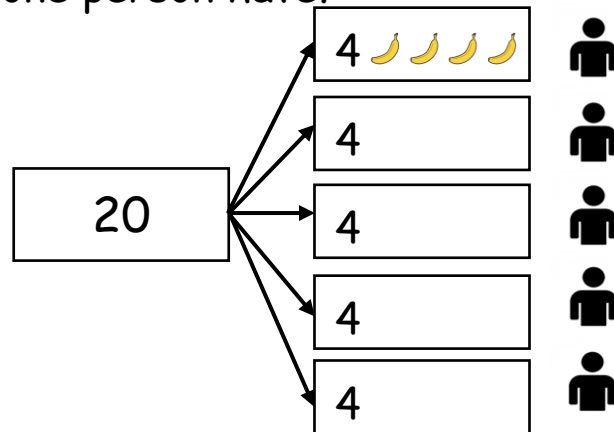
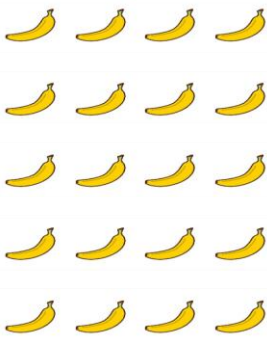

It is represented by the following math sentence.

$$\begin{array}{ccc}
 20 & \div & 5 = 4 \\
 \boxed{\text{Total Number}} & & \boxed{\text{Number of groups}} \quad \boxed{\text{Number in one group.}}
 \end{array}$$

- ① There are 480 tiles.
If we share them among 4 people, how many tiles does one person have?

Show your work.

Done !

If represents 1,



represents 10



represents 100

Extra

K'

How can you do division?

Date

/ 1 Points

There are 4.8 liters of cooking oil in one bottle.

We share it among 4 people. How many liters of cooking oil does each person have?



Show your work.

There are 4.8 liters of cooking oil in one bottle.
We share it among 4 people. How many liters of cooking oil does each person have?

Arthur's idea



If represents 0.1 liters, represents 1 liter
and represents 10 liters of cooking oil

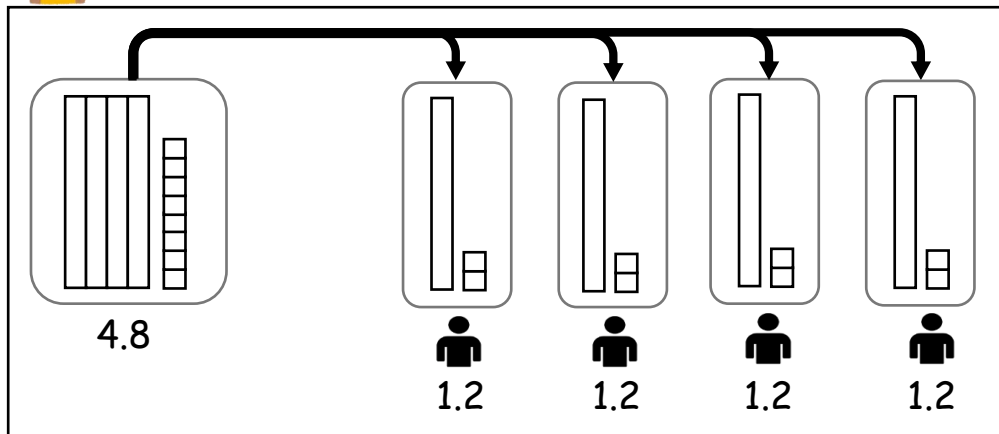

Mutinta's idea

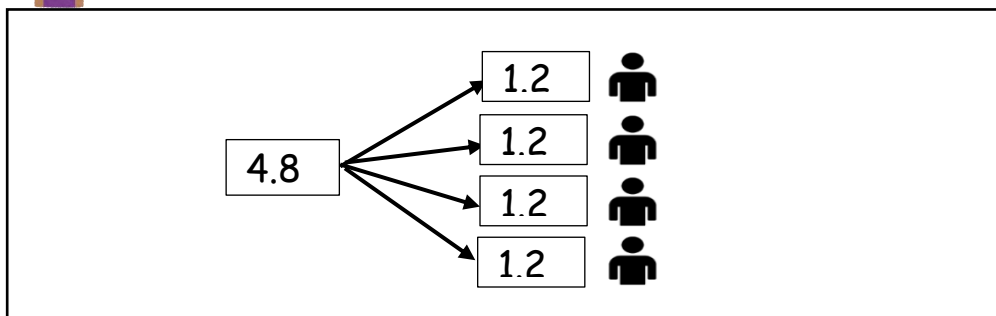

Total amount

Number of people

Amount per person

(Total amount of oil) ÷ (Number of people to share) = (Amount of oil per person)

$$\boxed{} \div \boxed{} = \boxed{}$$

Answer: liters

Do the following division.

① $2.4 \div 2 =$

Show your work.

② $3.6 \div 3 =$

Show your work.

③ $8.4 \div 4 =$

Show your work.

① $1.2 \times 3 =$

$$\begin{array}{r} 1.2 \\ \times 3 \\ \hline 3.6 \end{array}$$



Calculate from right.

② $2.1 \times 4 =$

$$\begin{array}{r} 2.1 \\ \times 4 \\ \hline \end{array}$$

③ $0.2 \times 4 =$

$$\begin{array}{r} 0.2 \\ \times 4 \\ \hline 0.8 \end{array}$$



Calculate from right.

④ $0.3 \times 2 =$

$$\begin{array}{r} 0.3 \\ \times 2 \\ \hline \end{array}$$

⑤ $3.1 \times 4 =$

$$\begin{array}{r} 3.1 \\ \times 4 \\ \hline \end{array}$$

⑥ $6.2 \times 2 =$

$$\begin{array}{r} 6.2 \\ \times 2 \\ \hline \end{array}$$

⑦ $2.5 \times 3 =$

$$\begin{array}{r} 2.5 \\ \times 3 \\ \hline 1.5 \\ + 6 \\ \hline 7.5 \end{array}$$

2 + 0.5

0.5 \times 3

2 \times 3

⑧ $1.3 \times 4 =$

$$\begin{array}{r} 1.3 \\ \times 4 \\ \hline \end{array}$$

① $3.6 \div 3 =$

💡 Calculate from left.

$$\begin{array}{r}
 1 \ . \ 2 \\
 3 \overline{) 3 \ 6} \\
 \underline{3} \\
 0 \ 6 \\
 \underline{0 \ 6} \\
 0
 \end{array}$$

② $2.8 \div 2 =$

$$\begin{array}{r}
 \ . \ \\
 \overline{) } \\
 \underline{} \\
 \\
 \underline{ } \\

 \end{array}$$

③ $0.8 \div 4 =$

$$\begin{array}{r}
 \ . \ \\
 \overline{) } \\
 \underline{} \\
 \\
 \underline{ } \\

 \end{array}$$

④ $5.7 \div 3 =$

$$\begin{array}{r}
 \ . \ \\
 \overline{) } \\
 \underline{} \\
 \\
 \underline{ } \\

 \end{array}$$

⑤ $48.4 \div 4 =$

💡 Calculate from left.

$$\begin{array}{r}
 1 \ 2 \ . \ 1 \\
 4 \overline{) 4 \ 8 \ 4} \\
 \underline{4} \\
 0 \ 8 \\
 \underline{0 \ 8} \\
 0 \ 4 \\
 \underline{0 \ 4} \\
 0
 \end{array}$$

⑥ $33.6 \div 3 =$

$$\begin{array}{r}
 \ . \ \\
 \overline{) } \\
 \underline{} \\
 \\
 \underline{ } \\

 \end{array}$$

⑦ $1.8 \div 3 =$

💡 Calculate from left.

$$\begin{array}{r}
 0 \ . \ 6 \\
 3 \overline{) 1 \ 8} \\
 \underline{3} \\
 1 \ 8 \\
 \underline{1 \ 8} \\
 0
 \end{array}$$

⑧ $3.2 \div 4 =$

$$\begin{array}{r}
 \ . \ \\
 \overline{) } \\
 \underline{} \\
 \\
 \underline{ } \\

 \end{array}$$

Teachers Guide



Pupil's **Grade 3 & 4** Workbook

· Representing · Comparing · Calculating

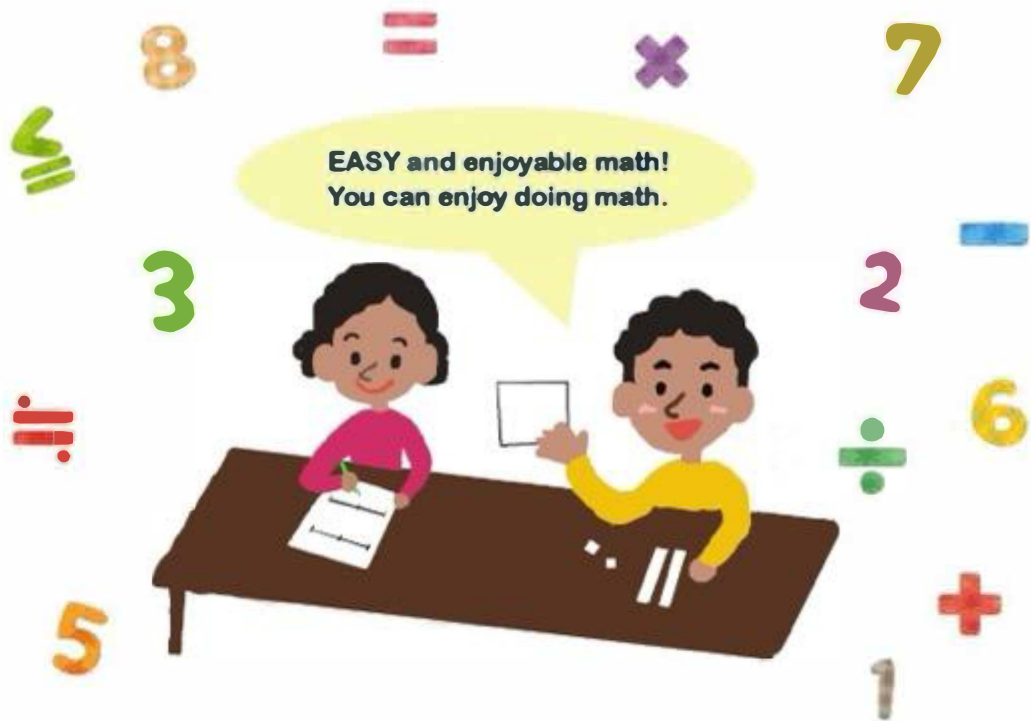

School: _____

Name: _____

Title: Pupils' workbook Grade 3 & 4

Author: ABE, Yoshitaka

BABA, Takuya

CHIKOLA, Doye

KAABO, Emmanuel

KOSAKA, Masato

KUSAKA, Satoshi

MAMBWE, Bareford

MINAGOSHI, Kanae

MUDENDA, Barbara

MUNGALU, Arthur

NAKAWA, Nagisa

NALUBE, Patricia

NKHATA, Bentry

SIKWALE, Shelly

TAFENI, Spiwe

TAKUZWA, Jane, Njovu

WATANABE, Koji

YUDA, Shiori

Acknowledgment: The authors thank Professors Joanne Mulligan and Michael Mitchelmore, School of Education, Macquarie University, Sydney, Australia for their expert guidance and review of the document.

Copyright © 2024, All Rights Reserved.

Forward

This is the teachers' guide to explain how to use the Pupils' workbook for Grade 3 & 4.

First, the page aims at monitoring the progress of pupils' learning. Please encourage them to learn steadily.

Second, the pages contain a list of contents. They are divided into four domains as I. Natural number representation, II. Comparison III. Calculation. Each domain is further divided into tasks.

Third, one page contains one task. There are two types of tasks Extra activity and Practice. Each Practice corresponds with the interview task in the interview guide. On the other hand, Extra activity aims at consolidating some foundation for the Practice. On each page, the layout typically shows the Task title, the Objective of the task, Tasks that appear in the workbook, and Important points for learning.

The layout for the domain page and task page

The Layout of the domain page

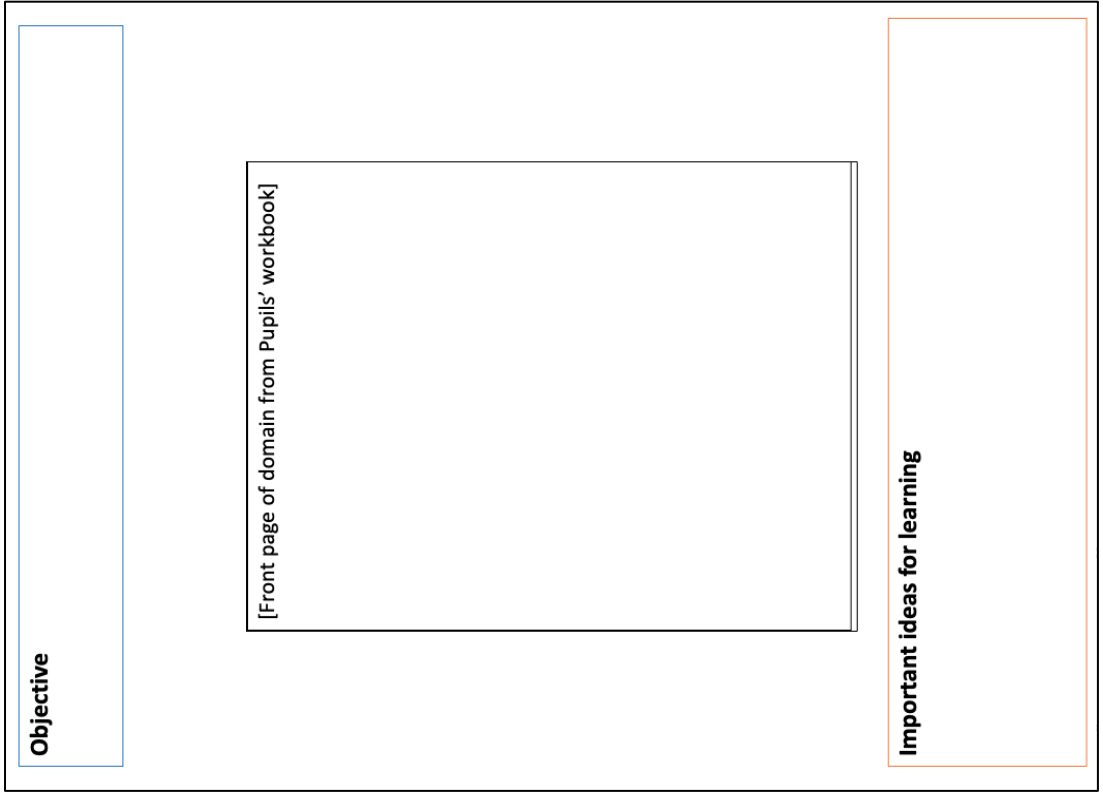

The Layout of the task page

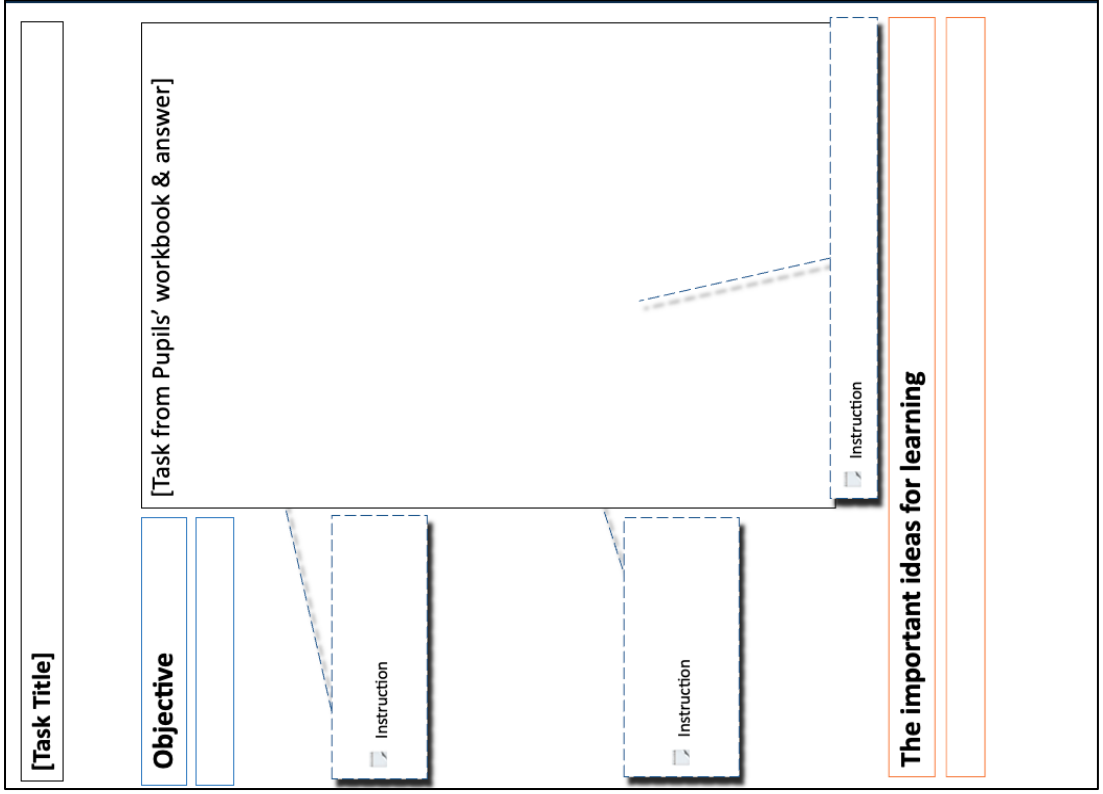

Note

1. In this teacher's guide, each task not only states the answer, but also asks the reason. This is because giving a reason leads to a deeper understanding of the concept.
2. Each task is according to the level of difficulty. Please be aware that you will be progressing from simple questions to more advanced questions.
3. As a general rule, places shall be spelled out (hundreds, tens and ones) and numbers in each place shall be indicated by Arabic numerals (100, 10, 1). This rule is not sometimes followed due to convenience.
4. In the teacher's guide, "grid" or "grids" are used instead of "grid/box" or "grids/boxes" in the pupil's workbook. They mean the same things.

Vili Mu Book

I. Mo onetsela	1
Extra activity A; Ma namba tingayaonese bwanji kusebenzesa ma grid?.....	2
Practice 1; Ma namba tingayaonese bwanji kusebenzesa ma grid?.....	3
Practice 2; Ma namba tingayaonese bwanji kusebenzesa ma grid?.....	4
Extra activity B; Ma namba tingayaonese bwanji kusebenzesa numba line?.....	5
Practice 3; Ma namba tingayaonese bwanji kusebenzesa numba line?.....	6
Practice 4; Ma namba tingayaonese bwanji kusebenzesa numba line?.....	7
Practice 5; Ma namba tingayaonese bwanji? Kulinganiza njila zosiyana zooneselamo ma namba.....	8
Extra activity C; Ma namba tingayaonese bwanji kusebenzesa ma tile?.....	9
Extra activity D; Yesa ku drawing'a ma tiles.....	10
II. Kulinganiza	12
Extra activity E; Niyiti ikulu kusebenzesa ma tiles?.....	13
Practice 6; Niyiti ikulu kusebenzesa ma tiles?.....	14
Extra activity F; Niyiti ikulu kusebenzesa ma namba?.....	15
Practice 7; Niyiti ikulu kusebenzesa ma namba?.....	16
Extra activity G; Niyiti ikulu kusebenzesa numba line?.....	17
Practice 8; Niyiti ikulu kusebenzesa numba line?.....	18

III. Kupeza masamu	19
Extra activity H; Kusankaniza tichita bwanji?.....	20
Extra activity I; Kuchotsera tichita bwanji?.....	21
Practice 9; Kusankaniza muma colamu.....	22
Practice 10; Kuchotsera muma colamu.....	23
Extra activity J; Ma samu ya times tichita bwanji?.....	24
Practice 11; Ma samu ya times tichita bwanji?.....	25
Extra activity K; Ma samu ya divaidi by tichita bwanji? (1)	26
Extra activity L; Ma samu ya divaidi by tichita bwanji? (2)	27
Practice 12; Ma samu ya divaidi by tichita bwanji?.....	29
Practice 13; Ku peza ma samu ya times muma colamu.....	30
Practice 14; Ku peza ma samu ya divaidi by muma colamu.....	31

Objective

1. Recognize the number sense and the part-whole while using multiple representation.

I . Mo onetsela



Choyamba, tizaphunzila molangizila ma namba.
Tiyeni tiphunzile njila zosiyana zolangizila ma
namba na kulondolola?

The important ideas for learning

- Apply 10 frame using bottle tops to recognize the structure of multiple representations.
- Recognize and use multiple representations of numbers such as grids, number line, tiles, and numerals as preparation for natural numbers.
- Recognize and explain the structure between the part-whole.
- Telling reason strengthen understanding of concepts.

Extra activity A;

Ma namba tingayaonese bwanji kusebenzesa ma grid?

How do you represent the numbers using grids?

Objective

Partition the grids and read numbers using grids.

📖 Teach pupils to divide equally.

📖 **Waziba bwanji (Reason)** means that the teacher asks the pupils how to get the answer. (To be able to explain using own words.)

For example, 100 is composed of 10 part grids. Since the shaded grid is one, the answer is 10.

📖 Emphasize that 10 part grids are equivalent to 100 or 1000, therefore, 1 part grid is equal to 10 or 100 respectively.

Extra
A Ma namba tingayaonese bwanji
kusebenzesa ma grid?

Date _____ / 5 Points

① Gaba grid muma part yali 10 yolingana.



Nasiliza!

② Gaba grid muma part yali 10 yolingana.



Nasiliza!

③ Gaba grid muma part yali 10 yolingana.



Nasiliza!

④ Ngati aka ka grid  konse katantauza 100, tuma grid/box twamene ba shading'a tutantauza namba bwanji?

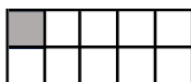

(Waziba bwanji?)

Nasiliza!

Ansa [10]

⑤ Ngati aka ka grid  konse katantauza 1000, tuma grid/box twamene ba shading'a tutantauza namba bwanji?

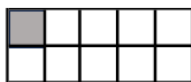

(Waziba bwanji?)

Nasiliza!

Ansa [100]

The important ideas for learning

- Partition the whole grid into 10 part equal-sized grids (5 upper and 5 lower).
- Recognize the relation in terms of quantity between whole and part grids.

Practice 1;

Ma namba tingayaonese bwanji kusebenzesa ma grid?

How do you represent the numbers using grids?

Objective

Read the circled number in the grids.

Teach pupils to recognize numbers quickly using a ten (2 x 5) frame.

Emphasize the relation in terms of quantity between whole and part grids.

Waziba bwanji
(Reason) means that the teacher asks the pupils how to get the answer.
For example, the answer is 480. Because circled grid contain 4 whole grids and 8 part grids.

Practice 1 Ma namba tingayaonese bwanji kusebenzesa ma grid?

Date / / 2 Points

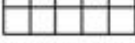
① Ngati aka ka grid  konse katantauza 100, tuma grid/box twamene ba sekoling'a tutantauza namba bwanji?

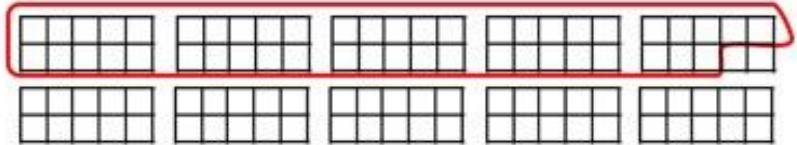

(Waziba bwanji?)

Ansa [480]

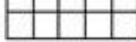
② Ngati aka ka grid  konse katantauza 100, tuma grid/box twamene ba sekoling'a tutantauza namba bwanji?

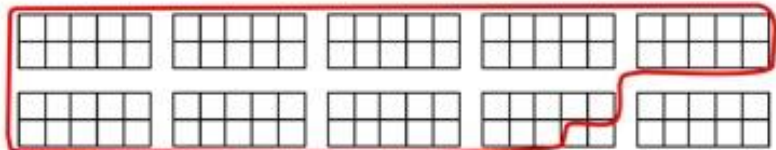

(Waziba bwanji?)

Ansa [880]

The important ideas for learning

- Use whole grids and part grids effectively in reading the quantity of encircled grids, count in hundreds and in tens.

Practice 2;

Ma namba tingayaonese bwanji kusebenzesa ma grid?

How do you represent the numbers using grids?

Objective

Circle the grids (with and without dividing lines) to represent the given number.

Ask pupils the relation between a whole grid (100) and part grids (10). For example, ten part grids make one whole grid.

Make the pupils divide the last whole grid equally into 10 equal parts and be able to encircle the grids exactly in ① - (2) and ②.

Waziba bwanji (Reason) means that the teacher asks the pupils how to get the answer. (To be able to explain using own words.)

Practice
2

Ma namba tingayaonese bwanji
kusebenzesa ma grid?

Date

/ 3 Points

①

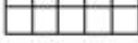
(1) Ngati aka ka grid  konse katantauza 100, sekoling'a 370 kusebenzesa tuma grid/box.

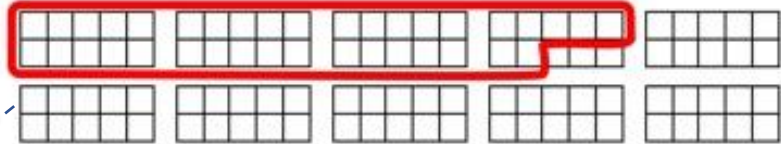

(Waziba bwanji?)

(2) Ngati aka ka grid  konse katantauza 100, sekoling'a 370 kusebenzesa tuma grid/box.

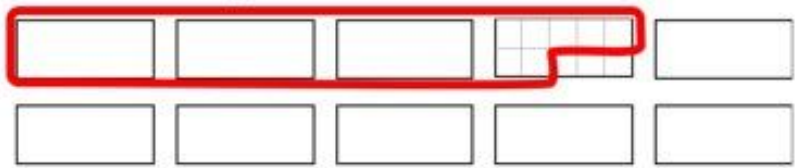

(Waziba bwanji?)

②

Ngati aka ka grid  konse katantauza 100, sekoling'a 720 kusebenzesa tuma grid/box.

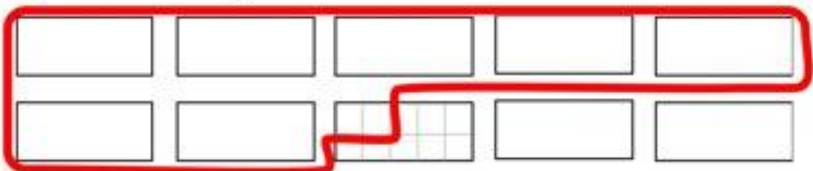

(Waziba bwanji?)

The important ideas for learning

- In ①, uses whole grids and part grids effectively in encircling the quantity in the grids.
- In ②, it is also necessary to partition the whole grid into 10 part same sized grids as well.

Extra activity B;

Ma namba tingayaonese bwanji kusebenzesa namba line?
How do you represent numbers using a number line?

Objective

Partition the number line and read the numbers along it.

Encourage each segment should be the same distance.

Waziba bwanji
(Reason) means that the teacher asks the pupils how to get the answer. (To be able to explain using own words.)

Extra
B

Ma namba tingayaonese bwanji
kusebenzesa namba line?

Date

/ 5 Points

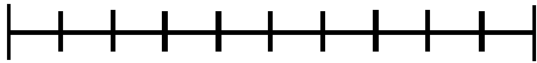
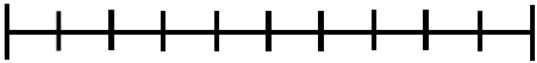
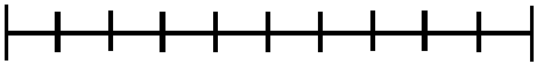
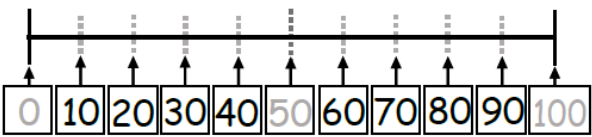
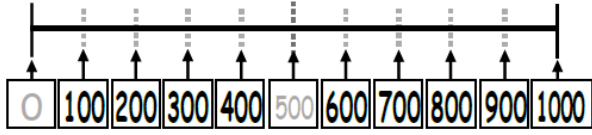
<p>① Gabanisa tunkale tolingana tuli 10. Penda ma part yonse kuyambila pa 0.</p> 	<input type="checkbox"/> Nasiliza!
<p>② Juba pakati elo ugabanise tunkale tolingana tuli 10. Penda ma part yonse kuyambila pa 0.</p> 	<input type="checkbox"/> Nasiliza!
<p>③ Juba pakati elo ugabanise tunkale tolingana tuli 10. Penda ma part yonse kuyambila pa 0.</p> 	<input type="checkbox"/> Nasiliza!
<p>④ Lemba ma namba yamene yafunika kunkala mu tuma box.</p>  <p>(Waziba bwanji?) 100 ili pa ka line kanamba 10, nishi koyambilila katantauza 10.</p>	<input type="checkbox"/> Nasiliza!
<p>⑤ Lemba ma namba yamene yafunika kunkala mu tuma box.</p>  <p>(Waziba bwanji?) 1000 ili pa ka line kanamba 100, nishi kayambilila katantauza 100.</p>	<input type="checkbox"/> Nasiliza!

The important ideas for learning

- Partition the whole segment on the number line into 10 part equal sized segments.
- Recognize the relation in terms of quantity between whole and part segments.
- Each segment should be the same distance.

Practice 3;

Ma namba tingayaonese bwanji kusebenzesa namba line?
How do you represent numbers using a number line?

Objective

Read and write the number indicated by an arrow on the number line.

Encourage pupils to think about the value of each of the 10 part segments.

Waziba bwanji (Reason) means that the teacher asks the pupils how to get the answer. (To be able to explain using own words.)

Practice 3 Ma namba tingayaonese bwanji kusebenzesa namba line? Date / 3 Points



(Waziba bwanji?)
Ansa [630]



(Waziba bwanji?)
Ansa [290]



(Waziba bwanji?)
530
Ansa [540]

The important ideas for learning

- Recognize whole and part segments effectively in reading the position of a number on the number line.
- Think about the value in terms of number of hundreds and tens.

Practice 4;

Ma namba tingayaonese bwanji kusebenzesa namba line?

How do you represent numbers using a number line?

Objective

Indicate the number along the number line with an arrow.

Ask pupils the relation whole segments (100s) and part segments (10s).

Encourage the pupils to divide the last whole segment into 10 equal parts and be able to identify the exact location using an arrow in ③.

Waziba bwanji (Reason) means that the teacher asks the pupils how to get the answer. (To be able to explain using own words.)

Encourage the pupils to **divide a divided part (10) further into 10 equal parts (1s)** in a magnified number line and be able to identify the location using an arrow in ④.

Practice 4 Ma namba tingayaonese bwanji kusebenzesa namba line? Date / 4 Points

Ika ka arrow pa ma namba line aya pamene pafunika ku nkhalama namba aya.

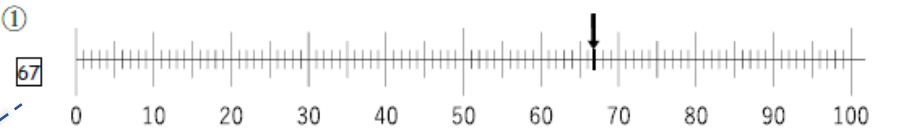
①  67

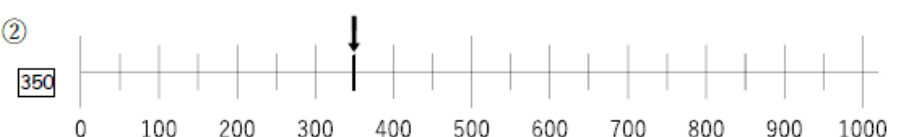
②  350

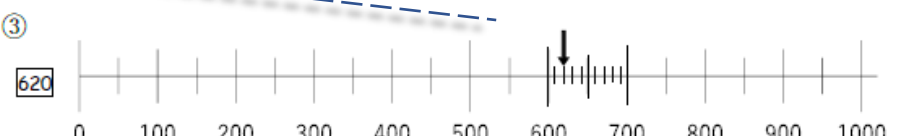
③  620 (Waziba bwanji?)

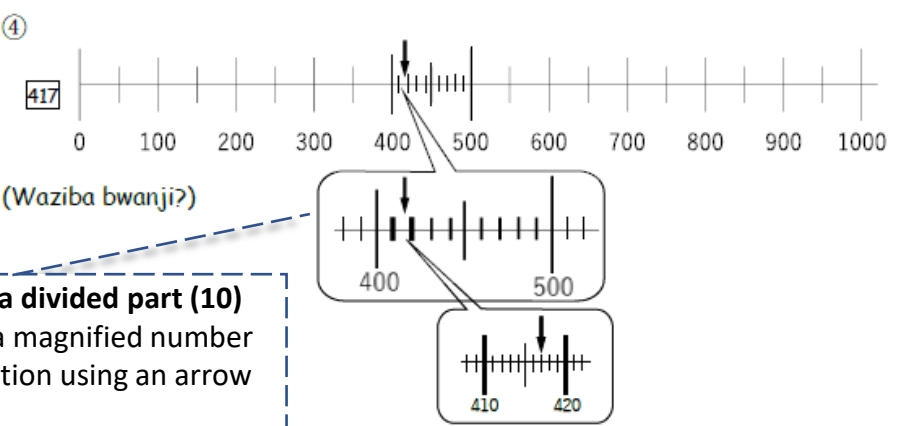
④  417 (Waziba bwanji?)

The important ideas for learning

- Use whole segments and part segments effectively to indicate the location of a number on the number line.
- In ③, it is necessary to partition whole segments into 10 equal - sized part segments.
- In ④, it is necessary to partition whole segments into 10 equal sized part segments and use approximation such as around 420.
- To be more accurate we can use magnified number line as in the above.

Practice 5;

Ma namba tingayaonese bwanji?

How do you represent numbers?: Connect different representations

Objective

Read the circled number in the grids and show it on the number line.

Encourage pupils to represent numbers of equal value, even if the representation format changes.

Waziba bwanji (Reason) means that the teacher the pupils how to get the answer. (To be able to explain using own words.)

For example, both a whole grid and a whole segment represent 100, and a part grid and a part segment represent 10. In other words, both represent 270, two wholes and seven parts.

Practice
5

Ma namba tingayaonese bwanji?

Kulinganiza njila zosiyana zooneselamo ma namba

Date

/ 2 Points

①

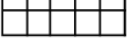
Ngati aka ka grid  konse katantauza 100, namba yamene ta sekoling'a ili pati pa namba line?

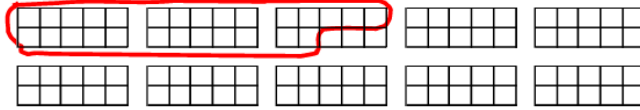

Kusebezesa ka arrow, onesa namba yamene wapeza pa namba line iyi.

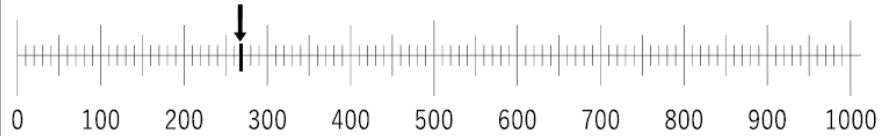

(Waziba bwanji?)

②

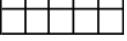
Ngati aka ka grid  konse katantauza 100, namba yamene ta sekoling'a ili pati pa namba line?

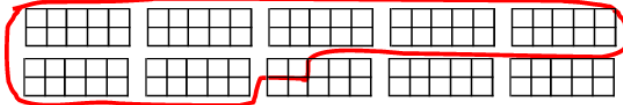

Kusebezesa ka arrow, onesa namba yamene wapeza pa namba line iyi.

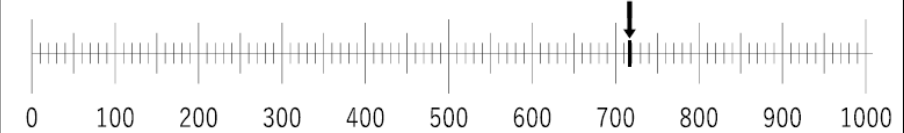

(Waziba bwanji?)

The important ideas for learning

- Correlate two different representations of quantity such as grids and segments on the number line.
- Correspondence between whole and part grids and whole and part segments is crucial.

Extra activity C;

Ma namba tingayaonese bwanji kusebenzesa ma tile?

How do you represent numbers using tiles?

Objective

Represent numbers using tiles.

Encourage pupils to understand different sizes of tiles.

Ask the pupils to confirm the part-whole relationship.

Encourage the pupils to learn the relationship between the numerals and tiles in each place.

Extra
C

Ma namba tingayaonese bwanji
kusebenzesa ma tile?

Date _____

/ 2 Points

Tipunzile ma namba kusebenzesa ma tiles.

Tuma 1 tuli 10 tupanga 10 imozi.

Tuma 1 tuli 100 tupanga 100 imozi.

Ma ten yali 10 yapanga 100 imozi.

-note-

Kangono katantauza 1

Katali katantauza 10

Kakulu katantauza 100

① Ma tiles aya yatantauza namba bwanji? Nasiliza!

Hundreds (100s)	Tens (10s)	Ones(1s)
Ansa [154]		

② Ma tiles aya yatantauza namba bwanji? Nasiliza!

Hundreds (100s)	Tens (10s)	Ones(1s)
Ansa [231]		

The important ideas for learning

- Recognize relation among large, long and small tiles effectively in representing the numbers.
- Confirm that 10 tiles of one are equivalent to 1 tile of ten, 10 tiles of ten are equivalent to 1 tile of hundred.

Extra activity D;

Yesa ku drawing'a ma tiles

Practice drawing the tiles

Objective

Draw tiles of 1s, 10s and 100s and use them for representation.

 Practice Part. Encourage pupils to understand the relations of tile size and number while drawing.

Extra

D Yesa ku drawing'a ma tiles.

Date

/ 7 Points

Tiyeni tichite practice ku drawing'a ma tiles yali mu exercise kuchoka pa ① kufika pa ③. Drawing'a ma tiles kuonesa ma namba yali mu exercise kuchoka pa ④ kufika pa ⑦.

① Yesa ku drawing'a tuma one utu tubwele 15 times

Nasiliza!



② Yesa ku drawing'a tuma tens utu tubwele 15 times

Nasiliza!



③ Yesa ku drawing'a tuma hundred utu tubwele 4 times

Nasiliza!

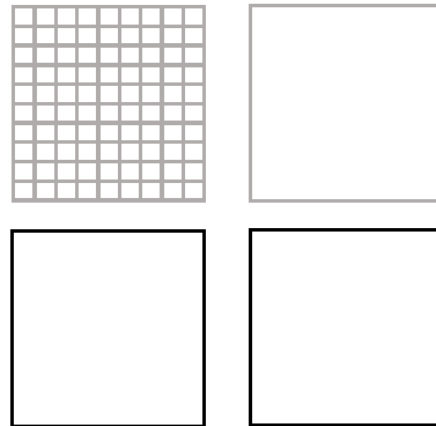

Pitiliza kufika pa page yamene ibwela.

Continue to the next page →

Continuation of the previous page

Encourage pupils to understand the relations of expanded notation and tiles while drawing.

Kupitiliza kuchoka ku page yamene yapita. Onesa mwamene waipezela.

④	$200 + 10 + 3 = 213$	<input type="checkbox"/> Nasiliza!
Hundreds (100s)	Tens (10s)	Ones(1s)
⑤	$100 + 40 + 2 = 142$	<input type="checkbox"/> Nasiliza!
Hundreds (100s)	Tens (10s)	Ones(1s)
⑥	$200 + 10 + 6 = 216$	<input type="checkbox"/> Nasiliza!
Hundreds (100s)	Tens (10s)	Ones(1s)
⑦	$200 + 60 + 3 = 263$	<input type="checkbox"/> Nasiliza!
Hundreds (100s)	Tens (10s)	Ones(1s)

The important ideas for learning

- Practice drawing large, long, and small tiles effectively, recognize their relation.
- Correspond such drawing with expanded notation.

Objective

1. Compare numbers while using multiple representations.
2. Explain how to get the answer using representation or your own words.

II . Kulinganiza

Bushe waziba kuonesha ma namba kusebenzesa
ma tiles?
Manje tiyeni tiyalinganize!



The important ideas for learning

- Use multiple different representations of numbers such as tiles, numerals, and number line for comparing quantities.

Extra activity E;

Niyiti ikulu kusebenzesa ma tiles?

Which quantity is bigger using tiles?

Objective

Compare the size of numbers using tiles.

Encourage pupils to pay attention to the quantity represented by tiles (the relationship between quantity and tile). Firstly, pay attention to long tiles (10s). If numbers of long tiles are the same, pay attention to small tiles (1s).

Waziba bwanji (Reason) means that the teacher asks the pupils how to get the answer. (To be able to explain using own words.)

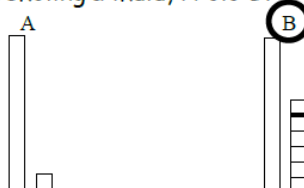
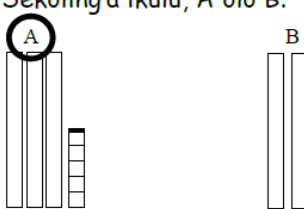
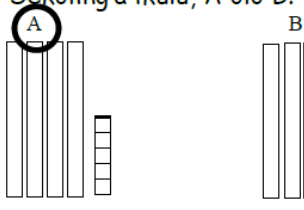
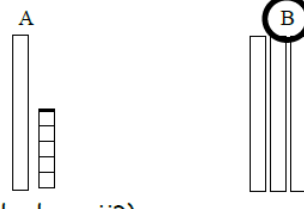
Extra E Niyiti ikulu kusebenzesa ma tiles?		Date _____ / 5 Points
<p>① Sekoling'a ikulu, A olo B.</p> 		<input type="checkbox"/> Nasiliza!
<p>② Sekoling'a ikulu, A olo B.</p> 		<input type="checkbox"/> Nasiliza!
<p>③ Sekoling'a ikulu, A olo B.</p>  <p>(Waziba bwanji?) Walinganiza na tile iti, itali olo ing'ono?</p> <p style="text-align: right;">ing'ono Ansa [(The small tile)]</p>		<input type="checkbox"/> Nasiliza!
<p>④ Sekoling'a ikulu, A olo B.</p>  <p>(Waziba bwanji?)</p>		<input type="checkbox"/> Nasiliza!

The important ideas for learning

- Compare two quantities, by using long tiles of 10 and small tiles of 1 effectively and thinking which tile to pay attention to.

Practice 6;

Niyiti ikulu kusebenzesa ma tiles?

Which quantity is bigger using tiles?

Objective

Compare the size of numbers using tiles.

Encourage learners to pay attention to the quantity represented by tiles (the relationship between quantity and tile).

Firstly, pay attention to large tiles (100s). If numbers of large tiles are the same, pay attention to long tiles (10s). If number of long tiles are the same, pay attention to small tiles (1s).

Waziba bwanji (Reason) means that the teacher asks the pupils how to get the answer. (To be able to write and explain using own words.)

Practice

6 Niyiti ikulu kusebenzesa ma tiles?

Date

/ 3 Points

①

(1) Sekoling'a ikulu, A olo B.

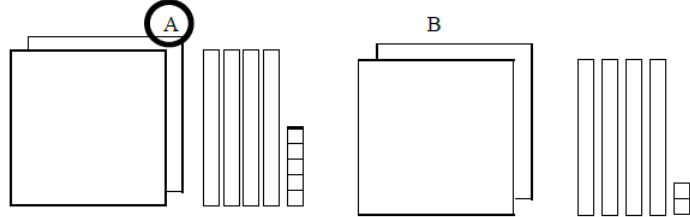

(Waziba bwanji?)

(2) Walinganiza na tile iti, ikulu, itali olo ing'ono?

ing'ono

Ansa [(The small tile)]

②

(2) Sekoling'a ikulu, A olo B.

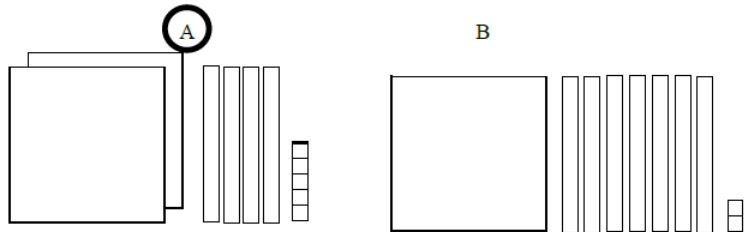

(Waziba bwanji?)

The important ideas for learning

- Compare two quantities, by using tiles of 100, 10 and 1 effectively and thinking which tile to pay attention to.

Extra activity F;

Niyiti ikulu kesebenzesa ma namba?

Which quantity is bigger using numerals?

Objective

Compare the size of numbers using numerals.

Encourage pupils to pay attention to tens and then ones places for comparing.

Waziba bwanji (Reason) means that the teacher asks the pupils how to get the answer. (To be able to write and explain using own words.) Encourage the pupils to understand the size effectively by paying attention to the position of place value. Teach them how to explain which quantities are bigger (more) or smaller (fewer) by paying attention to each place.

Extra

F Niyiti ikulu kusebenzesa ma namba?

Date

/ 6 Points

① Niyiti namba ikulu, 24 olo 29?

(Waziba bwanji?)

	Tens (10s)	Ones (1s)
24	2	4
29	2	9

Niyati ma place value yamene walinganiza, pali ma **Tens** na ma **Ones**?

Ansa [**Ones**]

Niyiti namba ikulu, **24** olo **29**?

Ansa [**29**]

Nasiliza!

② Niyiti namba ikulu, 73 olo 48?

(Waziba bwanji?)

	Tens (10s)	Ones (1s)
73	7	3
48	4	8

Niyati ma place value yamene walinganiza, pali ma **Tens** na ma **Ones**?

Ansa [**Tens**]

Niyiti namba ikulu, **73** olo **48**?

Ansa [**73**]

Nasiliza!

③ Niyiti namba ikulu, **84** olo **86**?

(Waziba bwanji?)

Ansa [**86**]

④ Niyiti namba ikulu, **59** olo **65**?

(Waziba bwanji?)

Ansa [**65**]

Nasiliza!

Nasiliza!

The important ideas for learning

- Compare two quantities, by thinking which place to pay attention to.
- Compare them from the larger place value.

Practice 7;

Niyiti ikulu kesebenzesa ma namba?

Which quantity is bigger using numerals?

Objective

Compare the size of numbers using numerals.

Encourage pupils to pay attention to place value (hundreds, tens, and ones) for comparing.

Waziba bwanji (Reason) means that the teacher asks the pupils how to get the answer. (To be able to write and explain using own words.)

Teach them how to explain which quantities are bigger (more) or smaller (fewer) by paying attention to each place.

Practice

7 Niyiti ikulu kesebenzesa ma namba?

Date

/ 21 Points

① Niyiti namba ikulu, 321 olo 325?

(1)

321 ilina [**3**] muma hundreds, [**2**] muma tens, na [**1**] muma ones.

325 ilina [**3**] muma hundreds, [**2**] muma tens, na [**5**] muma ones.

	Hundreds (100s)	Tens (10s)	Ones (1s)
321	3	2	1
325	3	2	5

(Waziba bwanji?)

(2) Niyati ma place value yamene walinganisa, pali ma **hundreds**, ma **tens**, na ma **ones**.

Ansa [**Ones**]

(3) Niyiti namba ikulu, 321 olo 325?

Ansa [**325**]

② Niyiti namba ikulu, 521 olo 359?

(1) Ma hundreds ma tens nama ones yaliyangati muma namba aya?

	Hundreds (100s)	Tens (10s)	Ones (1s)
521	5	2	1
359	3	5	9

(Waziba bwanji?)

Ansa [**521**]

The important ideas for learning

- Compare two quantities, by thinking which place to pay attention to.
- Compare them from the larger place value.

Extra activity G;

Niyiti ikulu kusebenzesa namba line?

Which quantity is bigger using a number line?

Objective

Compare the size of two numbers using number lines.

Encourage pupils to pay attention to the location of numbers on the numbers line for comparison.

Waziba bwanji (Reason) means that the teacher asks the pupils how to get the answer. (To be able to explain using own words.)

Extra

G Niyiti ikulu kusebenzesa namba line?

Date

/ 6 Points

① Niyiti namba ikulu, 20 olo 60?

Onesa ma namba, 20 na 60 kusebenzesa tuma arrow.

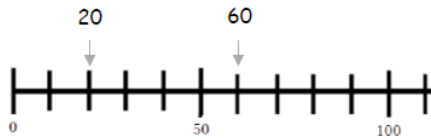

(Waziba bwanji?)

60 iliku **[right]** kwa 20, ndiye kuti 60 ni **[ikulu]** pali 20.

Nasiliza!

② Niyiti namba ikulu, 60 olo 90?

Onesa ma namba, 60 na 90 kusebenzesa tuma arrow.

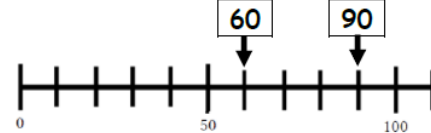

(Waziba bwanji?)

90 iliku **[right]** kwa 60, ndiye kuti 90 ni **[ikulu]** pali 60.

Nasiliza!

③ Niyiti namba ikulu, 110 olo 40?

Onesa ma namba, 110 na 40 kusebenzesa tuma arrow.

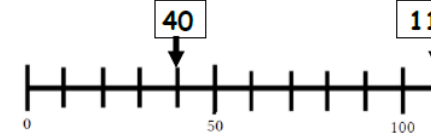

(Waziba bwanji?)

110 iliku **[right]** kwa 40, ndiye kuti 110 ni **[ikulu]** pali 40.

Nasiliza!

④ Niyiti namba ikulu, 110 olo 60?

Onesa ma namba, 110 na 60 kusebenzesa tuma arrow.

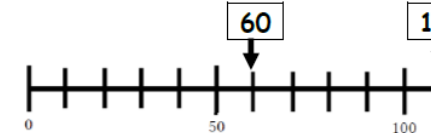

(Waziba bwanji?)

110 ikulu **right** kwa 60, ndiye kuti 110 ni **ikulu** pali 60.

Nasiliza!

The important ideas for learning

- Compare two quantities by thinking of their relative positions (right or left) on the number line.
- Recognize that the number which is on the right is bigger than the number which is on the left on the number line.

Practice 8;

Niyiti ikulu kusebenzesa namba line?

Which quantity is bigger using a number line?

Objective

Compare the size of numbers using number lines.

Encourage pupils to pay attention to the location of numbers on the numbers line for comparison.

Waziba bwanji (Reason) means that the teacher asks the pupils how to get the answer. (To be able to explain using own words.)

Practice

8 Niyiti ikulu kusebenzesa namba line?

Date

/ 4 Points

① Niyiti namba ikulu, 380 olo 310?

(1) Onetsa ma namba 380 na 310 kusebenzesa tuma arrow.

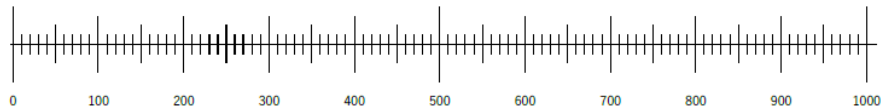

(Waziba bwanji?)

380 iliku **right** kwa 310, ndiye kuti 380 ni **ikulu** pali 310.

(2) Niyiti namba ikulu?

Ansa [**380**]

② Niyiti namba ikulu, 810 olo 260?

(1) Onesa ma namba 810 na 260 kusebenzesa ma arrow.

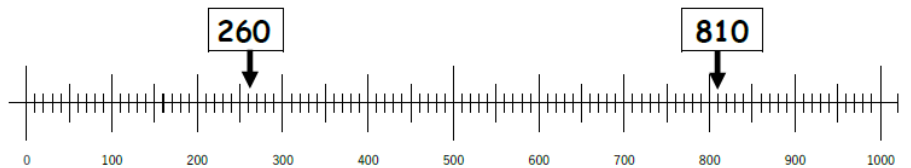

(Waziba bwanji?)

810 iliku **right** kwa 260, ndiye kuti 810 ni **ikulu** pali 260.

Ansa [**810**]

The important ideas for learning

- Compare two quantities by thinking of their relative positions (right or left) on the number line.
- Recognize that the number which is on the right is bigger than the number which is on the left on the number line.

Objective

1. Show the meaning of four fundamental operations using representations
2. Explain how to get the answer using representation.

III. Kupeza masamu

Chomaliza tizapeza ma ansa ya ma samu.
Tizaphunzila ma sainsi ya muma samu chamene
yatantauza.



Taphunzila kuti katantauza 1,



katantauza 10 elo



katantauza 100 polangiza.

Tiyeni titusebenzese kupeza ma samu!

The important ideas for learning

- Correlate calculation and representations such as tiles and numerals and explain how they did the calculation.

Extra activity H;

Kusankaniza tichita bwanji?

How can you do addition?

Objective

Show the meaning of addition using tiles.

Encourage pupils to understand and explain the meaning of addition through the use of representation.

Onesa mwamene waipezela. (Show your work) means that the teacher asks the pupils how to get the answer.

Encourage the pupils to correspond the numerals and tiles in each place.

Extra H Kusankaniza tichita bwanji? Date / 1 Points

Aka ka sign (+) katantauza chani?

Kuli ma eggs yali 30, ba Mr A baleta ma eggs yali 12. Kuli ma eggs yangati pamodzi?

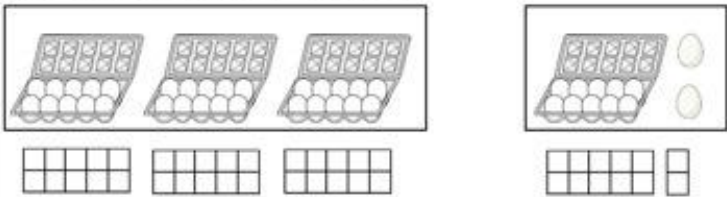

Tingaionese na sentence ya masamu iyi.

$$30 + 12 = 42$$

① Nili na ma tiles yali 245
Muzanga ali na ma tiles yali 122.
Tili na ma tiles yangati pamodzi?

Onesa mwamene waipezela.

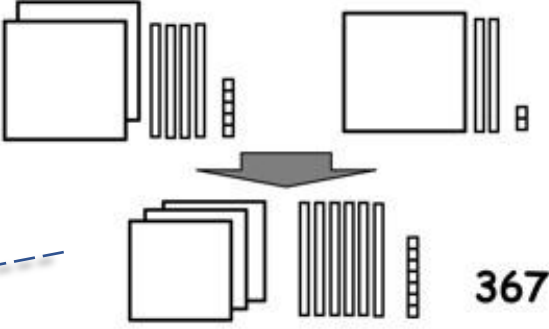

Nasiliza!

Ngati katantauza 1,
 katantauza 10,
 katantauza 100

The important ideas for learning

- Represent two numbers first and then show the meaning of addition using tiles (1s, 10s, and 100s).

Extra activity I;

Kusankaniza tichita bwanji?

How can you do subtraction?

Objective

Show the meaning of subtraction using tiles.

Encourages pupils to understand and explain the meaning of subtraction through the use of representation.

Onesa mwamene waipezela. (Show your work) means that the teacher asks the pupils how to get the answer.

Encourage the pupils to correspond the numerals and tiles in each place.

Extra I Kuchotsera tichita bwanji? Date / 1 Points

Aka ka sign (-) katantauza chani?

Kuli ma egg yali 20, ba Mr Banda banagula yali 14. Kunasala ma eggs yangati?

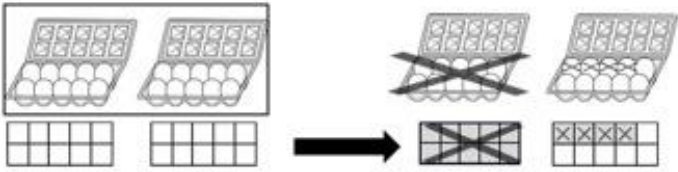

Tingaionese na sentence ya masamu iyi.
 $20 - 14 = 6$

① Nili na ma tiles yali 235.
Nina pasa muzanga yali 124.
Nili na ma tiles yangati?

Onesa mwamene waipezela.

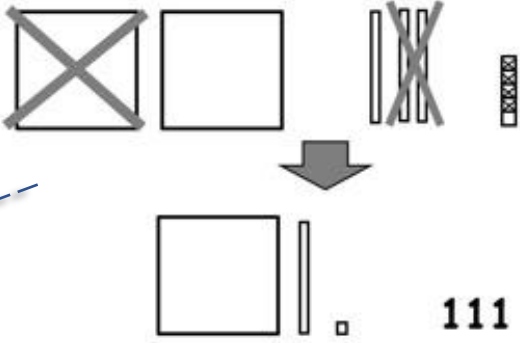

Nasiliza!

The important ideas for learning

- Represent two numbers first and then show the meaning of subtraction using tiles (1s, 10s, and 100s).

Practice 9;

Kusankaniza muma colamu.

Column calculations for addition.

Objective

Add numbers in columns.

Encourage pupils to do calculations from the ones place (right side).

⑤ ⑥ ⑦ have with carrying once. ⑧ has with carrying twice.

Practice 9 Kusankaniza muma colamu

Date / 8 Points

① $122+121=243$

$$\begin{array}{r} 122 \\ + 121 \\ \hline 243 \end{array}$$

Peza kuyambila ku right.

② $321+120=441$

$$\begin{array}{r} 321 \\ + 120 \\ \hline 441 \end{array}$$

③ $157+422=579$

$$\begin{array}{r} 157 \\ + 422 \\ \hline 579 \end{array}$$

④ $222+314=536$

$$\begin{array}{r} 222 \\ + 314 \\ \hline 536 \end{array}$$

⑤ $348+213=561$

$$\begin{array}{r} 348 \\ + 213 \\ \hline 561 \end{array}$$

Peza kuyambila ku right.

⑥ $129+314=443$

$$\begin{array}{r} 129 \\ + 314 \\ \hline 443 \end{array}$$

⑦ $274+143=417$

$$\begin{array}{r} 274 \\ + 143 \\ \hline 417 \end{array}$$

⑧ $178+122=300$

$$\begin{array}{r} 178 \\ + 122 \\ \hline 300 \end{array}$$

Teach the pupils to align the numbers neatly by place value.

The important ideas for learning

- Show how to add numbers with and without carrying in column form.
- It is very important to align the numbers neatly by place value when writing the numbers in column.

Practice 10;

Kusankaniza muma colamu.

Column calculations for subtraction.

Objective

Subtract numbers in columns.

Encourage pupils to do calculations from the ones place (right side).

⑤ ⑥ ⑦ ⑧ have with borrowing.

Teach the pupils to align the numbers neatly by place value.

Practice

10 Kuchotsera muma colamu

Date _____

/ 8 Points

① $243 - 121 = 122$

$$\begin{array}{r} 243 \\ - 121 \\ \hline 122 \end{array}$$

Peza kuyambila ku right.

② $379 - 143 = 236$

$$\begin{array}{r} 379 \\ - 143 \\ \hline 236 \end{array}$$

③ $368 - 125 = 243$

$$\begin{array}{r} 368 \\ - 125 \\ \hline 243 \end{array}$$

④ $444 - 102 = 342$

$$\begin{array}{r} 444 \\ - 102 \\ \hline 342 \end{array}$$

⑤ $561 - 348 = 213$

$$\begin{array}{r} \boxed{5} \quad \boxed{10} \\ 561 \\ - 348 \\ \hline 213 \end{array}$$

Peza kuyambila ku right.

⑥ $671 - 125 = 546$

$$\begin{array}{r} \boxed{6} \quad \boxed{10} \\ 671 \\ - 125 \\ \hline 546 \end{array}$$

⑦ $360 - 126 = 234$

$$\begin{array}{r} \boxed{5} \quad \boxed{10} \\ 360 \\ - 126 \\ \hline 234 \end{array}$$

⑧ $207 - 123 = 84$

$$\begin{array}{r} \boxed{1} \quad \boxed{10} \\ 207 \\ - 123 \\ \hline 84 \end{array}$$

The important ideas for learning

- Show how to subtract numbers with and without borrowing in column form.
- It is very important to align the numbers neatly by place value when writing the numbers in column.

Extra activity J;

Ma samu ya times tichita bwanji?

How can you do multiplication?

Objective

Show the meaning of multiplication using tiles and correspond it with multiplication sentence.

Encourages pupils to understand and explain the meaning of multiplication through the use of representation.

Onesa mwamene waipezela. (Show your work) means that the teacher asks the pupils how to get the answer.

Encourage the pupils to represent multiplicand and multiplier by tiles and find an answer by corresponding tiles and numerals in each place.

Date: _____ / 1 Points

Extra J Ma samu ya times tichita bwanji?

Aka ka sign(x) katantauza chani?

Pa mbale iliyonse pali ma banana yatatu; kuti kuli ma mbale yali 5, pali ma banana yali 15.
Uli na ma banana yangati?



ingaionese na sentence ya masamu iyi.

$$3 + 3 + 3 + 3 + 3 = 15$$

Ma gulu yali 5 yama banana yatatu

$$5 \times 3 = 15$$

5	×	3	=	15
Namba ya ma gulu		Namba mugulu imodzi		Niyangati pamodzi

① Kuli ma gulu yatatu, yama tiles yali 120. Nasilizal
Yali yangati yonse pamozi?

Onesa mwamene waipezela.

multiplicand



multiplier

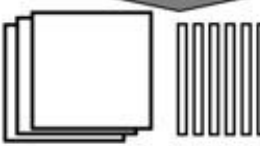

$3 \times 120 = 360$

360

The important ideas for learning

- Represent the quantity (multiplicand) first using tiles (1s, 10s, and 100s), and then repeat it number of times (multiplier).
- (multiplier) x (multiplicand) = (product)

Practice 11;

Ma samu ya times tichita bwanji?

How can you do multiplication?

Objective

Express the meaning of multiplication as repeated addition.

 Ask pupils what are multiplier and multiplicand in each.

 Multiplier (number of the group) comes first, multiplicand (number in the group) comes later in multiplication sentence.

Practice

11 Ma samu ya times tichita bwanji?

Date _____

/ 4 Points

Mumalo yo onesa sentence ya times iyi, ungaonesa bwanji kuti inkale sentence ya plus?

① $4 \times 210 = 210 + 210 + 210 + 210$

② $2 \times 420 = 420 + 420$

Mumalo yo onesa sentence ya plus iyi, ungaonesa bwanji kuti inkale sentence ya times?

② $310 + 310 + 310 = 3 \times 310$

③ $130 + 130 + 130 + 130 = 4 \times 130$

The important ideas for learning

- Represent an operation of multiplication using repeated addition or vice versa.

Extra activity K;

Ma samu ya divaidi by tichita bwanji? (1)

How can you do division? (1)

Objective

Show the meaning of division using tiles and correspond it with division sentence.

Encourages pupils to understand and explain the meaning of division through the use of representation.

Onesa mwamene waipezela. (Show your work) means that the teacher asks the pupils how to get the answer.

Encourage the pupils to represent dividend and divisor by tiles and find an answer by corresponding tiles and numerals in each place.

Extra
K Ma samu ya divaidi by tichita bwanji? (1)

Date _____ / 1 Points

Aka ka sign (-) katantauza chani?

Kuli ma banana yali 20. Tingabanisa bantu bali 5 molingana. Muntu umodzi anatenga ma banana angati?

20

4

4

4

4

4

Tingaionese na sentence ya masamu iyi.

20 ÷

5 =

4

Namba ya ma gulu

Namba ya ma gulu

Namba mugulu imodzi

① Pali ma tile 480. Tagabanisa bantu bali 4 molingana. Muntu umozi azankala na yangati ma tile? Nasiliza!

Onesa mwamene waipezela

divisor

$480 \div 4 = 120$

dividend

120

120

The important ideas for learning

- Represent the quantity (dividend) first, using tiles (1s ,10s, and 100s), and then share equally into number of groups (divisor).
- (dividend) ÷ (divisor) = (quotient)

Extra activity L;

Ma samu ya divaidi by tichita bwanji? (2)

How can you do division? (2)

Objective

Show the meaning of division using tiles and correspond it with division sentence.

Extra L Ma samu ya divaidi by tichita bwanji? (2) Date: / / 1 Points

Kuli ma sweet yali 360. Ngati bantu batatu bagabana molingana, muntu umodzi azatenga ma sweet angati?

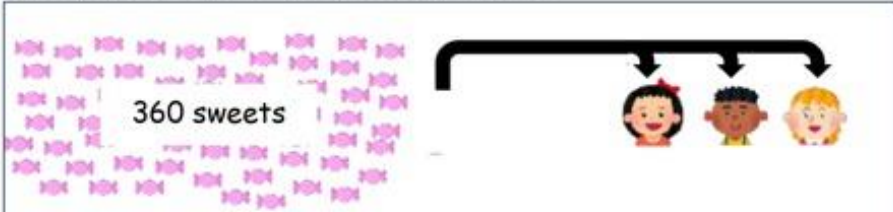

Onesa mwamene waipezela.

See the ideas on the next page.



Onesa mwamene waipezela. (Show your work)

means that the teacher asks the pupils how to get the answer.

For example, see the ideas on the next page or column calculation.

Continue to next page

Continuation of the previous page

Kuli ma sweet yali 360. Ngati bantu batatu bagabana molingana, muntu umodzi azatenga ma sweet angati?

Arthur's idea



Ngati katantauza sweet umozi, katantauza 10 sweets, katantauza 100 sweets

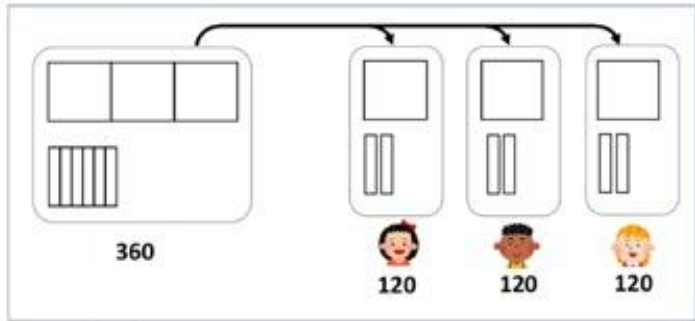

Mutinta's idea

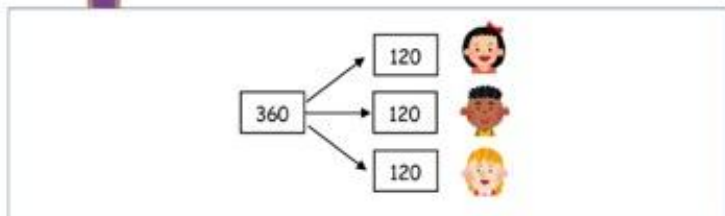

Niyangati pamodzi

Namba ya ma gulu

Namba mugulu imodzi

(Namba ya ma sweet pamodzi) \div (Namba ya bantu bazagabana) = (Namba ya ma sweet muntu umodzi azatenga)

360

\div

3

=

120

Ansa: **120** sweets

📄 Respect diverse ideas. There are ways to get answers such as the usage of tiles and thinking from daily life experiences.

📄 The meaning of division is explained in words. The teacher may read it with learners to understand the meaning.

The important ideas for learning

- Represent the quantity (dividend) first, using tiles (1s, 10s, and 100s), and then share equally into number of groups (divisor).
- (dividend) \div (divisor) = (quotient)

Practice 12;

Ma samu ya divaidi by tichita bwanji?

How can you do division?

Objective

Divide numbers horizontally.

Onesa mwamene waipezela.

(Show your work) means that the teacher asks pupils how to get the answer.

For example, the teacher might encourage the pupils to use the ideas from Arthur and Mutinta that they learned in the previous lesson.

 Ask the pupils what are dividend and divisor in each.

Practice 12 Ma samu ya divaidi by tichita bwanji? Date _____ / 3 Points

Peza division iyi.

① $240 \div 2 = 120$
Onesa mwamene waipezela.

Example 1.

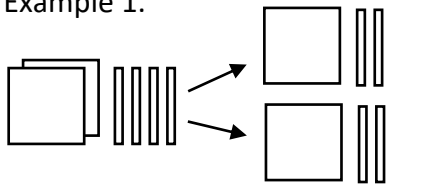

Example 2.

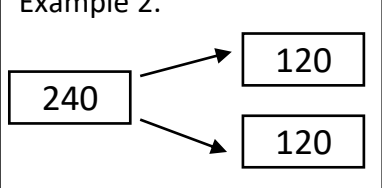

② $360 \div 3 = 120$
Onesa mwamene waipezela.

③ $840 \div 4 = 210$
Onesa mwamene waipezela.

The important ideas for learning

- Represent an operation of division using tiles and/or expanded notation.

Practice 13;

Ku peza ma samu ya times muma colamu.
Column calculations for multiplication.

Objective

Multiply numbers in columns.

Encourage pupils to do calculations from the ones place (right side).

Encourage the pupils to do multiplication in each place.

Teach the pupils to align the numbers neatly by place value.

Practice 13 Ku peza ma samu ya times muma colamu

Date / 8 Points

$12 \times 3 = 36$ $\begin{array}{r} 12 \\ \times 3 \\ \hline 36 \end{array}$ <p>Peza kuyambila ku right.</p>	$21 \times 4 = 84$ $\begin{array}{r} 21 \\ \times 4 \\ \hline 84 \end{array}$
$310 \times 3 = 930$ $\begin{array}{r} 310 \\ \times 3 \\ \hline 930 \end{array}$ <p>Peza kuyambila ku right.</p>	$120 \times 2 = 240$ $\begin{array}{r} 120 \\ \times 2 \\ \hline 240 \end{array}$
$212 \times 4 = 848$ $\begin{array}{r} 212 \\ \times 4 \\ \hline 848 \end{array}$	$303 \times 2 = 606$ $\begin{array}{r} 303 \\ \times 2 \\ \hline 606 \end{array}$
$150 \times 3 = 450$ $\begin{array}{r} 150 \\ \times 3 \\ \hline 450 \end{array}$ <p>100×3 50×3 100×3</p>	$250 \times 3 = 750$ $\begin{array}{r} 250 \\ \times 3 \\ \hline 750 \end{array}$

The important ideas for learning

- Show how to do multiplication with and without carrying in column form.
- It is very important to align the numbers neatly by place value when writing the numbers in the column.

Practice 14;

Ku peza ma samu ya divaidi by muma colamu.
Column calculations for division.

Objective

Divide numbers in columns (long division).

Encourage pupils to do calculations from the hundreds or tens place (left side).

Encourage the pupils to be aware of the position place value.

Teach the pupils to align the numbers neatly by place value.

Practice
14

Ku peza ma samu ya divaidi by muma colamu

Date

/ 8 Points

① $36 \div 3 = 12$

Peza kuanwila ku right. left.

$$\begin{array}{r} 12 \\ 3 \overline{) 36} \\ \underline{3} \\ 06 \\ \underline{06} \\ 0 \end{array}$$

② $48 \div 2 = 24$

$$\begin{array}{r} 24 \\ 2 \overline{) 48} \\ \underline{4} \\ 08 \\ \underline{08} \\ 0 \end{array}$$

③ $484 \div 4 = 121$

Peza kuanwila ku right. left.

$$\begin{array}{r} 121 \\ 4 \overline{) 484} \\ \underline{4} \\ 08 \\ \underline{08} \\ 04 \\ \underline{04} \\ 0 \end{array}$$

④ $336 \div 3 = 112$

$$\begin{array}{r} 112 \\ 3 \overline{) 336} \\ \underline{3} \\ 03 \\ \underline{03} \\ 06 \\ \underline{06} \\ 0 \end{array}$$

⑤ $260 \div 2 = 130$

$$\begin{array}{r} 130 \\ 2 \overline{) 260} \\ \underline{2} \\ 06 \\ \underline{06} \\ 00 \end{array}$$

⑥ $804 \div 4 = 201$

$$\begin{array}{r} 201 \\ 4 \overline{) 804} \\ \underline{8} \\ 00 \\ \underline{00} \\ 04 \\ \underline{04} \\ 0 \end{array}$$

⑦ $270 \div 3 = 90$

Peza kuyambila ku right.

$$\begin{array}{r} 90 \\ 3 \overline{) 270} \\ \underline{2} \\ 07 \\ \underline{07} \\ 00 \end{array}$$

⑧ $324 \div 4 = 81$

$$\begin{array}{r} 81 \\ 4 \overline{) 324} \\ \underline{3} \\ 02 \\ \underline{02} \\ 04 \\ \underline{04} \\ 0 \end{array}$$

Importance idea for leaning

- Show how to do division with and without borrowing in column form.
- It is very important to align the numbers neatly by place value when writing the numbers in the column.



Pupil's

Grade
5 & 6

Workbook

• Representing • Comparing • Calculating

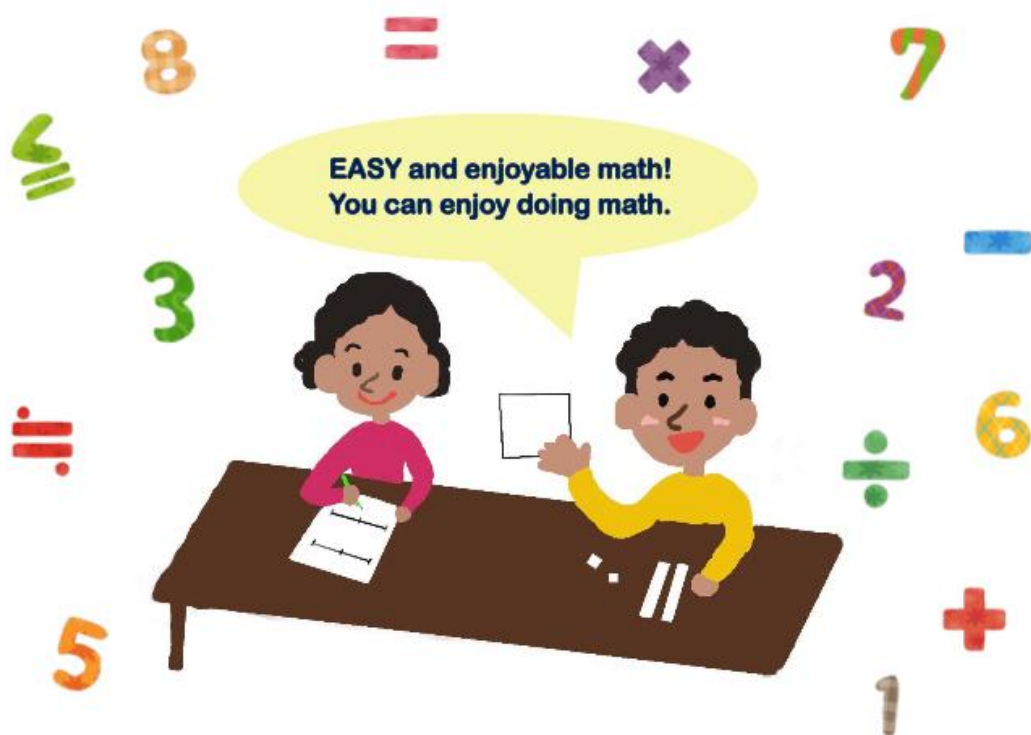

School: _____

Name: _____

Title: Pupils' workbook for Grade 5 & 6

Author: ABE, Yoshitaka

BABA, Takuya

CHIKOLA, Doye

KAABO, Emmanuel

KOSAKA, Masato

KUSAKA, Satoshi

MAMBWE, Bareford

MINAGOSHI, Kanae

MUDENDA, Barbara

MUNGALU, Arthur

NAKAWA, Nagisa

NALUBE, Patricia

NKHATA, Bentry

SIKWALE, Shelly

TAFENI, Spiwe

TAKUZWA, Jane, Njovu

WATANABE, Koji

YUDA, Shiori

Acknowledgment: The authors thank Professors Joanne Mulligan and Michael Mitchelmore, School of Education, Macquarie University, Sydney, Australia for their expert guidance and review of the document.

Forward

This is the teachers' guide to explain how to use the Pupils' workbook for Grade 5 & 6.

First, the page aims at monitoring the progress of pupils' learning. Please encourage them to learn steadily.

Second, the pages contain a list of contents. They are divided into four domains as I . Natural number representation, II . Decimal number representation, III . Comparison, IV . Calculation. Each domain is further divided into tasks.

Third, one page contains one task. There are two types of tasks Extra activity and Practice. Each Practice corresponds with the interview task in the interview guide. On the other hand, Extra activity aims at consolidating some foundation for the Practice. On each page, the layout typically shows the Task title, the Objective of the task, Tasks that appear in the workbook, and Important points for learning.

The layout for the domain page and task page

The Layout of the task page

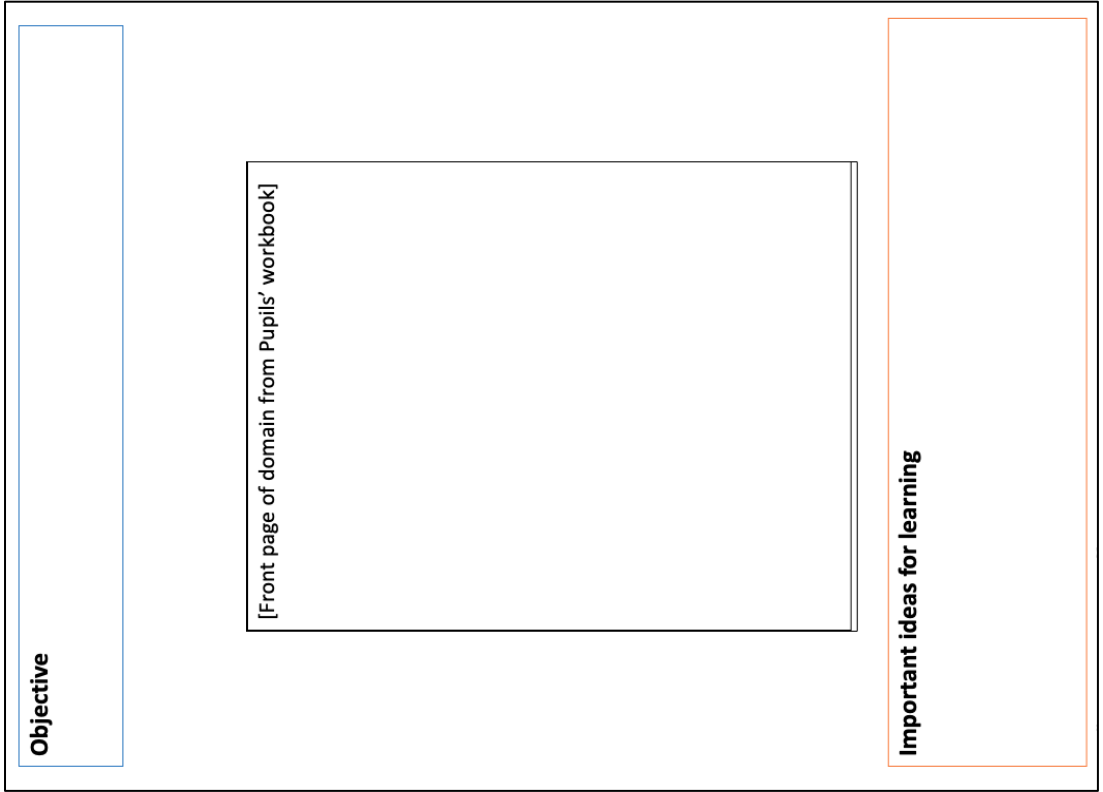

The Layout of the domain page

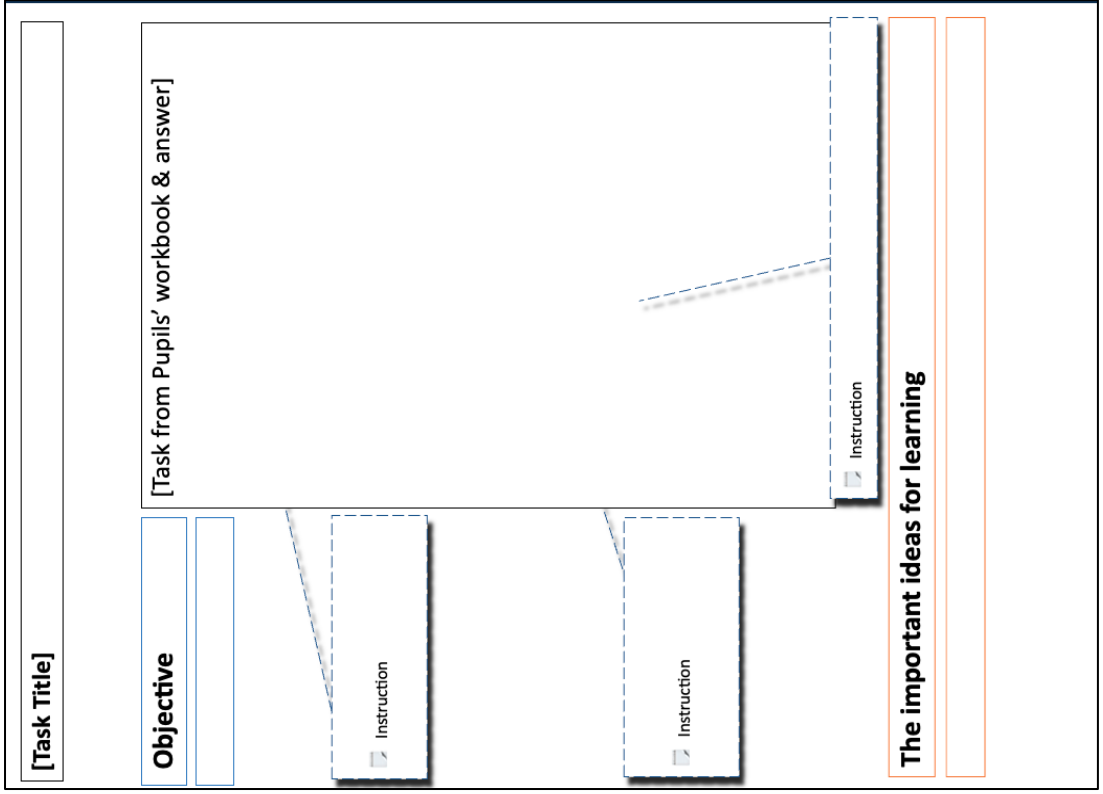

Note

1. In this teacher's guide, each task not only states the answer, but also asks the reason. This is because giving a reason leads to a deeper understanding of the concept.
2. Each task is according to the level of difficulty. Please be aware that you will be progressing from simple questions to more advanced questions.
3. As a general rule, places shall be spelled out (hundreds, tens and ones) and numbers in each place shall be indicated by Arabic numerals (100, 10, 1). This rule is not sometimes followed due to convenience.
4. In the teacher's guide, "grid" or "grids" are used instead of "grid/box" or "grids/boxes" in the pupil's workbook. They mean the same things.

Progress check sheet

Name: _____

Date	Content
<small>Example</small> 30 March	Extra A
	Extra activity NA
	Practice N1
	Extra activity NB
	Practice N2
	Extra activity A
	Practice 1
	Practice 2
	Extra activity B
	Practice 3
	Practice 4
	Practice 5
	Extra activity C
	Extra activity D
	Extra activity E
	Practice 6
	Extra activity F
	Practice 7
	Extra activity G

Date	Content
	Practice 8
	Extra activity H
	Extra activity H'
	Extra activity I
	Extra activity I'
	Practice 9
	Practice 10
	Extra activity J
	Extra activity J'
	Practice 11
	Extra activity K
	Extra activity K'
	Practice 12
	Practice 13
	Practice 14

Content

I . Natural number representation.....	1
Extra activity NA; How do you represent the numbers using grids?.....	2
Practice N1; How do you represent the numbers using grids?.....	3
Extra activity NB; How do you represent the numbers using a number line?.....	4
Practice N2; How do you represent the numbers using a number line?.....	5
II. Decimal number representation	6
Extra activity A; How do you represent the numbers using grids?.....	7
Practice 1; How do you represent the numbers using grids?.....	8
Practice 2; How do you represent the numbers using grids?.....	9
Extra activity B; How do you represent the numbers using a number line?.....	10
Practice 3; How do you represent the numbers using a number line?.....	11
Practice 4; How do you represent the numbers using a number line?.....	12
Practice 5; How do you represent the numbers?: Connect different representations.....	13
Extra activity C; How do you represent numbers using tiles?.....	14
Extra activity D; Practice drawing the tiles.....	15

III. Comparison	17
Extra activity E; Which quantity is more using tiles?.....	18
Practice 6; Which quantity is more using tiles?.....	19
Extra activity F; Which quantity is bigger using numerals?.....	20
Practice 7; Which quantity is bigger using numerals?.....	21
Extra activity G; Which quantity is bigger using a number line?.....	22
Practice 8; Which quantity is bigger using a number line?.....	23
IV. Calculation	24
Extra activity H; How can you do addition?.....	25
Extra activity H'; How can you do addition?.....	26
Extra activity I; How can you do subtraction?.....	27
Extra activity I'; How can you do subtraction?.....	28
Practice 9; Column calculations for addition.....	29
Practice 10; Column calculations for subtraction.....	30
Extra activity J; How can you do multiplication?.....	31
Extra activity J'; How can you do multiplication?.....	32
Practice 11; How can you do multiplication?.....	33
Extra activity K; How can you do division?.....	34
Extra activity K'; How can you do division?.....	35
Practice 12; How can you do division?.....	37
Practice 13; Column calculations for multiplication.....	38
Practice 14; Column calculations for division.....	39

Objective

1. Recognize the number sense and the part-whole while using multiple representations.

I . Natural Number representation

We review how to represent natural numbers.
Let's learn about various representations and
written explanations (reasons).



The importance ideas for leaning

- Apply 10 frame using bottle tops to recognize the structure of multiple representations.
- Recognize and use multiple representations of numbers such as grids, number line, tiles, and numerals as preparation for natural numbers.
- Recognize and explain the structure between the part-whole.
- Telling reason strengthen understanding of concepts.

Extra activity NA ; How do you represent the numbers using grids?

Objective

Read the numbers in the different units of grids (1, 10, 100, 1000).

Teach pupils to recognize numbers quickly by ten (2 x 5) frame.

Reason means that the teacher asks the pupils how to get the answer. (To be able to explain using own words.)

For example, the answer is 1. Because 10 is composed of 10 small grids. So the shaded grid is 1.

Extra NA How do you represent the numbers using grids? Date / / 3 Points

① If the whole of this grid  represents 10, what number does the shaded grid/box represent? Done !

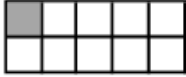

(Reason)

Answer [**1**]

② If the whole of this grid  represents 100, what number do the shaded grids/boxes represent? Done !



(Reason)

Answer [**60**]

③ If the whole of this grid  represents 1000, what number do the shaded grids/boxes represent? Done !

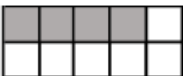

(Reason)

Answer [**400**]

The importance ideas for leaning

- Use whole grids and part grids effectively in reading the quantity of shaded grids, count in hundreds and in tens.

Practice N1 ; How do you represent the numbers using grids?

Objective

Read and encircle the numbers in the grids (with and without dividing lines).

Teach pupils to recognize numbers quickly by ten (2 x 5) frame.

Reason means that the teacher asks the pupils how to get the answer. (To be able to explain using own words.) For example, the answer is 480. Because circled grids contain 4 whole grids and 8 part grids.

Encourage the pupils divide the last whole grid equally into 10 equal parts and be able to encircle the grids exactly in ②.

Practice

N1 How do you represent the numbers using grids?

Date

/ 2 Points

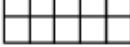
- ① If the whole of this grid  represents 100, what number is represented by the circled grids/boxes?

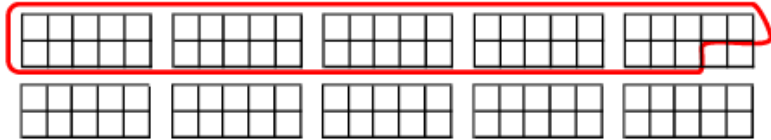

(Reason)

Answer [**480**]

- ② If the whole of this grid  represents 100, circle 720 using the grids/boxes.

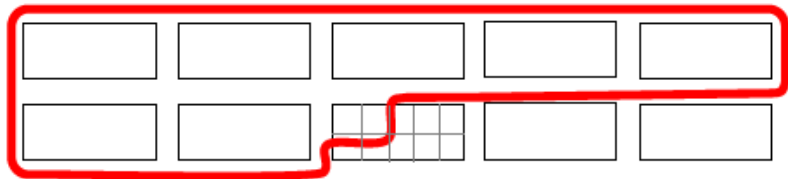

(Reason)

The importance ideas for leaning

- In ①, uses whole grids (hundreds) and part grids (tens) effectively in reading the quantity in the encircled grids.
- In ②, partition the last whole grid into part equal-sized grids and encircle the quantity in the grids.

Extra activity NB; How do you represent the numbers using a number line?

Objective

Read the relation in terms of quantity between whole and part segments.

 Emphasize the relation in terms of quantity between whole and part segments.

 **Reason** means that the teacher asks the pupils how to get the answer. (To be able to explain using own words.)

Extra NB

How do you represent the numbers using a number line?

Date

/ 3 Points

① Write the missing numbers in the boxes. Count each part from 0.

Done !

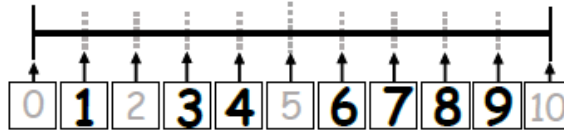

(Reason)

10 is on the 10th demarcation, so the 1st demarcation is 1.

② Write the missing numbers in the boxes. Count each part from 0.

Done !

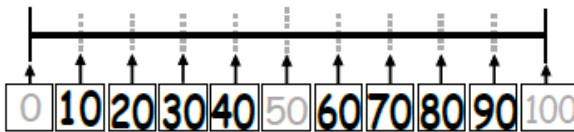

(Reason)

100 is on the 10th demarcation, so the 1st demarcation is 10.

③ Write the missing numbers in the boxes. Count each part from 0.

Done !

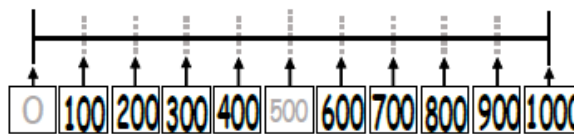

(Reason)

1000 is on the 10th demarcation, so the 1st demarcation is 100.

The importance ideas for leaning

- Use whole and part segments effectively in reading the position on the number line, count in hundreds and in tens.
- Each segment should be the same distance.

Practice N2 ; How do you represent the numbers using a number line?

Objective

1. Read the number indicated by an arrow.
2. Indicate the number with an arrow on the number line.

 Encourage pupils to think about the value of each of the 10 part segments.

 **Reason** means that the teacher asks the pupils how to get the answer. (To be able to explain using own words.)

Practice
N2

How do you represent the numbers using a number line?

Date

/ 3 Points

- ① What number is indicated by the arrow on the number line?

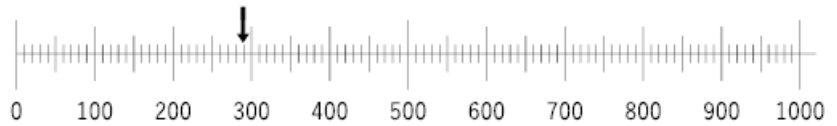

(Reason)

Answer [**290**]

- ② Indicate the following numbers on the number lines with an arrow.

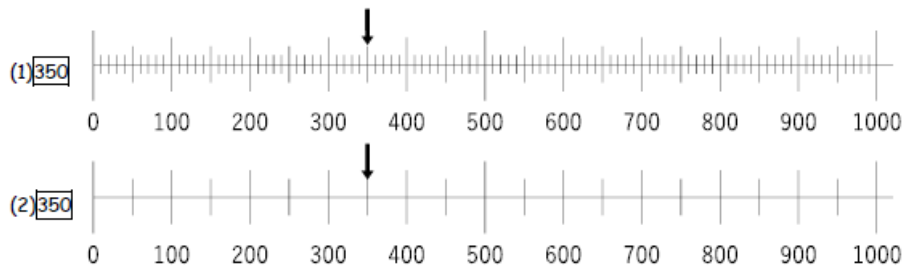

(Reason)

The importance ideas for leaning

- Recognize whole and part segments effectively in reading the position of a number on the number line.
- Think about the value in terms of number of hundreds and tens.

Objective

1. Recognize the number sense and the part-whole while using multiple representations.

II. Decimal Number representation



We learn how to represent decimal numbers!
Let's learn about various representations and
written explanations (reasons).

The importance ideas for leaning

- Recognize and use multiple representations of decimal numbers such as grids, number line, tiles, and numerals.
- Recognize and explain the structure between the part-whole.
- Apply 10 frame for recognizing the structure.

Extra activity A; How do you represent the numbers using grids?







Objective

Partition the grids and read the number using grids.

Teach pupils to divide equally.

Emphasize the relation in terms of quantity between whole and part grids.

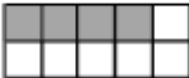
Reason means that the teacher asks the pupils how to get the answer. (To be able to explain using own words.)

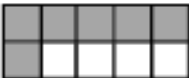
Extra		Date
A How do you represent the numbers using grids? / 6 Points		
① Divide the grid into 10 equal parts.		<input type="checkbox"/> Done !
② Divide the grid into 10 equal parts.		<input type="checkbox"/> Done !
③ Divide the grid into 10 equal parts.		<input type="checkbox"/> Done !
④ If the whole of this grid  represents 1, what number do the shaded grids/ boxes represent? (Reason)		<input type="checkbox"/> Done !
Answer [0.4]		
⑤ If the whole of this grid  represents 1, what number do the shaded grids/ boxes represent? (Reason)		<input type="checkbox"/> Done !
Answer [0.6]		

The importance ideas for leaning

- Partition the whole grid into 10 part equal-sized grids (5 upper and 5 lower).
- Recognize that 10 part grids are equivalent to 1, therefore, 1 part grid is equal to 0.1.

Practice 1 ; How do you represent the numbers using grids?

Objective

Read the circled decimal number in the grids.

Ask pupils about the relation between a whole grid (1) and part grids (0.1). For example, ten part grids make one whole grid.

Reason means that the teacher asks the pupil how to get the answer. (To be able to explain using own words.)

Practice
1

How do you represent the numbers using grids?

Date: _____ / 2 Points

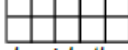
- ① If the whole of this grid  represents 1, what number is represented by the circled grids/boxes?

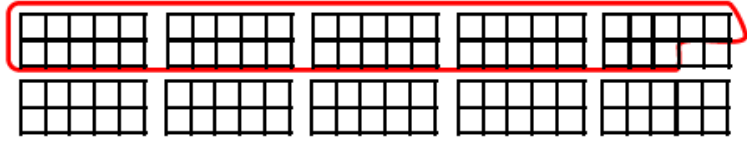

(Reason)

Answer [**4.8**]

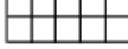
- ② If the whole of this grid  represents 1, what number is represented by the circled grids/boxes?

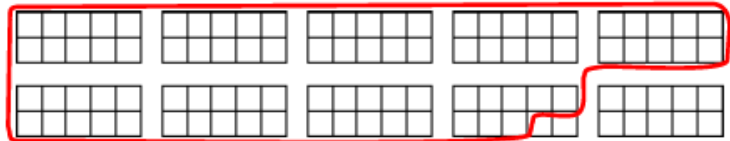

(Reason)

Answer [**8.8**]

The importance ideas for leaning

- Use whole grids and part grids effectively in reading the quantity of encircled grids.
- Count how many whole grids (1), and part grids (0.1).

Practice 2; How do you represent the numbers using grids?

Objective

Circle the grids (with and without dividing lines) to represent the given decimal number.

Ask pupils about the relation between a whole grid (1) and part grids (0.1).

Reason means that the teacher asks the pupils how to get the answer. (To be able to explain using own words.)

Encourage the pupils to divide the last whole grid equally into 10 equal parts and be able to encircle the grids exactly in ① - (2) and ②.

Practice
2

How do you represent the numbers using grids?

Date _____ / 3 Points

①

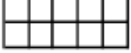
(1) If the whole of this grid  represents 1, circle 3.7 using the grids/boxes.

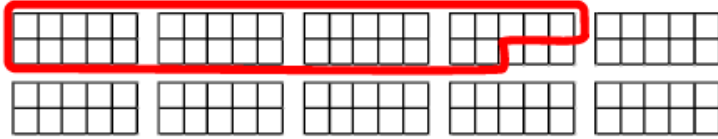

(Reason)

(2) If the whole of this grid  represents 1, circle 3.7 using the grids/boxes.

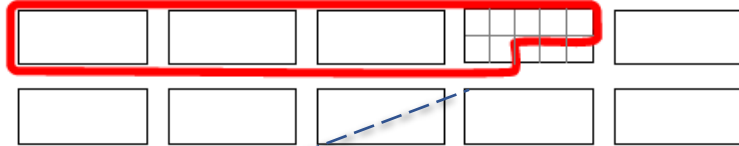

(Reason)

②

If the whole of this grid  represents 1, circle 7.2 using the grids/boxes.

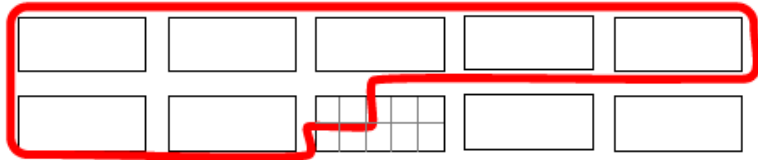

(Reason)

The importance ideas for leaning

- In ①, uses whole grids and part grids effectively in encircling the quantity in the grids.
- In ②, it is necessary to partition the whole grid into 10 part same sized grids as well.

Extra activity B; How do you represent numbers using a number line?

Objective



Partition the number line and read the decimal numbers along it.

Encourage each segment should be the same distance.

Reason means that the teacher asks the pupils how to get the answer. (To be able to explain using own words.)

Date _____ / 5 Points

Extra B How do you represent the numbers using a number line?

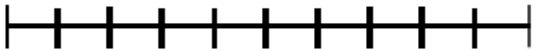
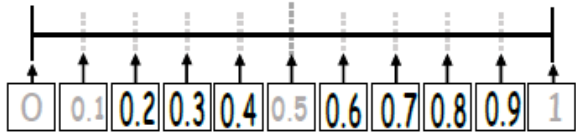
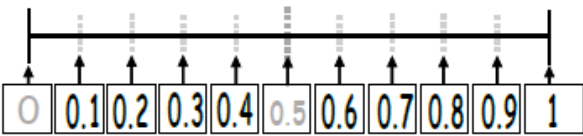
<p>① Divide the following into 10 equal parts. Count each part from 0.</p> 	<input type="checkbox"/> Done !
<p>② Cut in half, then divide into 10 equal parts. Count each part from 0.</p> 	<input type="checkbox"/> Done !
<p>③ Cut in half, then divide into 10 equal parts. Count each part from 0.</p> 	<input type="checkbox"/> Done !
<p>④ Write missing numbers in the boxes.</p>  <p>(Reason) 1 is on the 10th demarcation, so the 1st demarcation is <u>0.1</u>.</p>	<input type="checkbox"/> Done !
<p>⑤ Write the missing numbers in the boxes.</p>  <p>(Reason) 1 is on the 10th demarcation, so the 1st demarcation is 0.1.</p>	<input type="checkbox"/> Done !

The importance ideas for leaning

- Partition the whole segment on the number line into 10 part equal-sized segments.
- Emphasize the relation in terms of quantity between whole and part segments.
- Each segment should be the same distance.

Practice 3; How do you represent the numbers using a number line?

Objective

Read and write the number indicated by an arrow on the number line.

Encourage pupils to think about the value of each of the 10 part segments.

Reason means that the teacher asks the pupils how to get the answer. (To be able to explain using own words.)

Practice 3 How do you represent the numbers using a number line?

Date / 3 Points

① What number is indicated by the arrow on the number line?

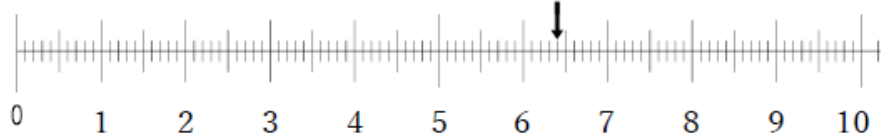

(Reason)

Answer [6.4]

② What number is indicated by the arrow on the number line?

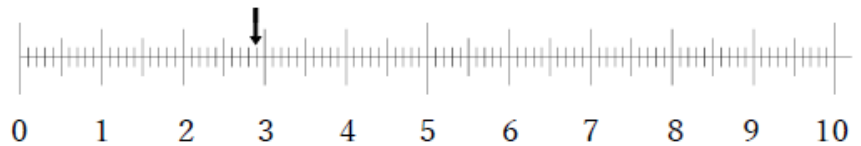

(Reason)

Answer [2.9]

③ What number is indicated by the arrow on the number line?

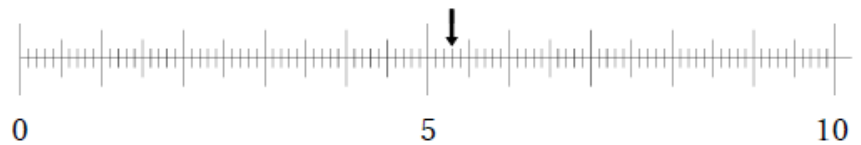

(Reason)

Answer [5.3]

The importance ideas for leaning

- Recognize whole and part segments effectively in reading the position of a number on the number line.
- Think about the value in terms of number of ones and tenths.

Practice 4; How do you represent numbers using a number line?

Objective

Indicate the decimal numbers along the number line with an arrow.

Ask pupils the relation whole segments (1s) and part segments (0.1s).

Encourage the pupils to divide the last whole segment equally into 10 equal parts and be able to locate the exact location using an arrow in ③ and ④.

Reason means that the teacher asks the pupils how to get the answer. (To be able to explain using own words.)

The pupils may have different perceptions, for example, estimation or dividing into 5 equal parts.

Practice 4 How do you represent the numbers using a number line?

Date / 4 Points

Indicate the following numbers on the number lines with an arrow.

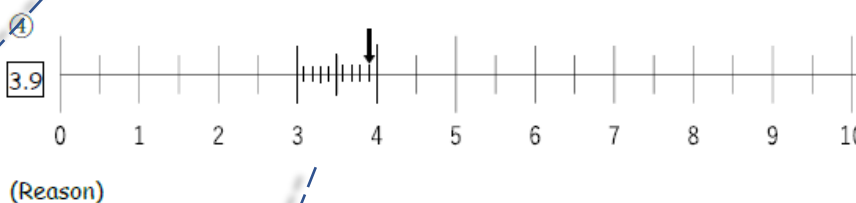
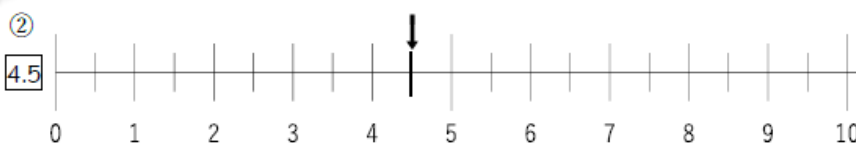
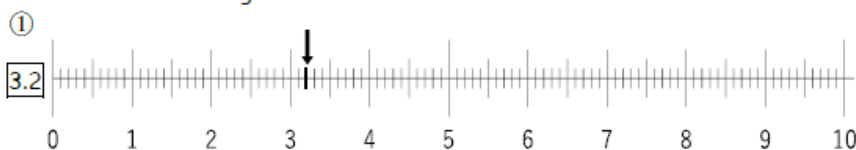

The importance ideas for leaning

- Use whole segments and part segments effectively to indicate the location of a number on the number line.
- It is necessary to partition the last whole segment into 10 equal-sized part segments in ③ & ④.

Practice 5; How do you represent numbers?: Connect different representations

Objective

Read the circled number in the grids and show it on the number line.

Encourage pupils to represent numbers of equal value, even if the representation format changes.

Reason means that the teacher asks the pupils how to get the answer. (To be able to explain using own words.) For example, both a whole grid and a whole segment represent 1, and a part grid and a part segment represent 0.1. In other words, both represent 2.7, two wholes and seven parts.

Practice
5

How do you represent the numbers?:
Connect different representations.

Date

/ 2 Points

① If the whole of this grid  represents 1, what number do the circled grids/ boxes represent?

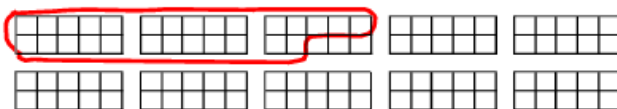

Indicate the above number on the number line with an arrow.

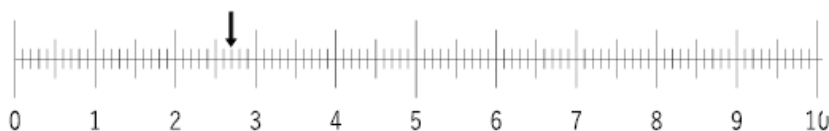

(Reason)

② If the whole of this grid  represents 1, what number do the circled grids/ boxes represent?

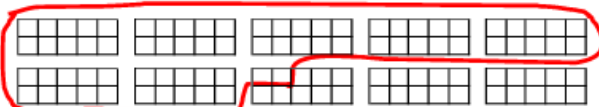

Indicate the above number on the number line with an arrow.

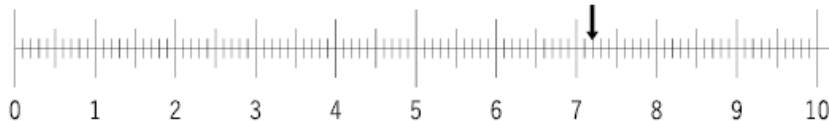

(Reason)

The importance ideas for leaning

- Correlate two different representations of quantity such as grids and segments on the number line.
- Correspondence between whole and part grids and whole and part segments is crucial.

Extra activity C ; How you represent numbers using tiles?

Objective

Represent numbers using tiles.

Encourage pupils to understand the different sizes of tiles.

Ask the pupils to confirm the part-whole relationship.

Encourage the pupils to learn the relationship between the numerals and tiles in each place.

Extra
C

How do you represent numbers using tiles?

Date

/ 2 Points

Let's learn number relationships using tiles.

10 tenths make 1 one.

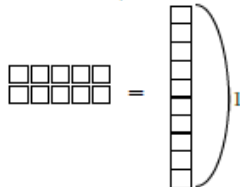

100 tenths make 1 ten.

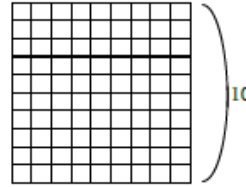

-note-

A small tile represents 0.1

A long tile represents 1

A large tile represents 10

10 ones make 1 ten.

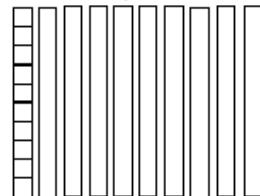

① What number is represented by the tiles?

Done !

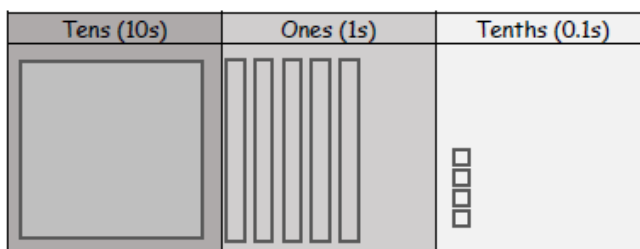

Answer [15.4]

② What number is represented by the tiles?

Done !

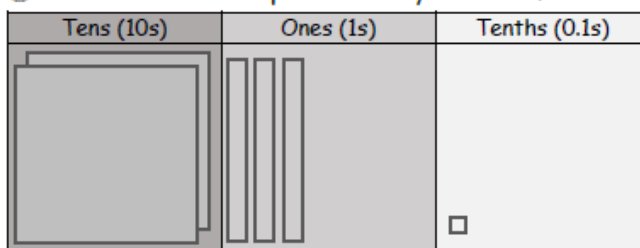

Answer [23.1]

The importance ideas for leaning

- Recognize the relation among large, long, and part tiles effectively in representing the numbers.
- Confirms that 10 tiles of tenth are equivalent to 1 tile of one, and 10 tiles of one are equivalent to 1 tile of ten.

Extra activity D; Practice drawing the tiles

Objective

Draw tiles of 0.1s, 1s, and 10s and use them for representation.

 Practice Part. Encourage pupils to understand the relations of tile size and number while drawing.

Extra

D Practice drawing the tiles.

Date

/ 7 Points

Let's practice drawing the frame of the tiles in exercises ① to ③.
Draw the tiles to represent the numbers in exercises ④ to ⑦.

① Tenths (practice 15 times)

Done !



② Ones (practice 15 times)

Done !

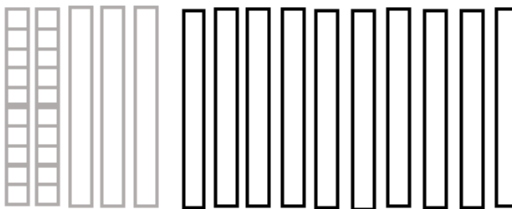

③ Tens (practice 4 times)

Done !

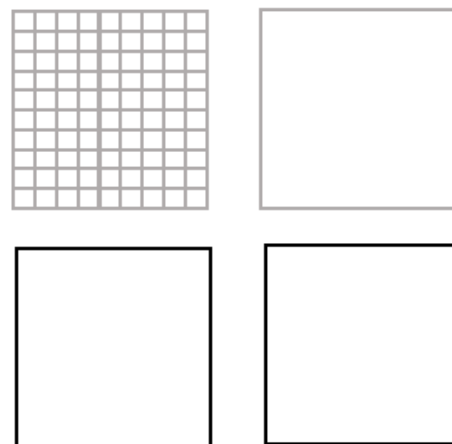

Continue to the next page.

Continue of the next page →

Continuation of the previous page

Encourage pupil to understand the relations of expanded notation and tiles while drawing.

Continuation of the previous page. Show your works.

④	$20 + 1 + 0.4 = 21.4$	4	<input type="checkbox"/> Done !					
	<table border="1"> <thead> <tr> <th>Tens (10s)</th> <th>Ones (1s)</th> <th>Tenths (0.1s)</th> </tr> </thead> <tbody> <tr> <td></td> <td></td> <td></td> </tr> </tbody> </table>	Tens (10s)	Ones (1s)	Tenths (0.1s)				
Tens (10s)	Ones (1s)	Tenths (0.1s)						
⑤	$10 + 2 + 0.3 = 12.3$		<input type="checkbox"/> Done !					
	<table border="1"> <thead> <tr> <th>Tens (10s)</th> <th>Ones (1s)</th> <th>Tenths (0.1s)</th> </tr> </thead> <tbody> <tr> <td></td> <td></td> <td></td> </tr> </tbody> </table>	Tens (10s)	Ones (1s)	Tenths (0.1s)				
Tens (10s)	Ones (1s)	Tenths (0.1s)						
⑥	$10 + 4 + 0.2 = 14.2$		<input type="checkbox"/> Done !					
	<table border="1"> <thead> <tr> <th>Tens (10s)</th> <th>Ones (1s)</th> <th>Tenths (0.1s)</th> </tr> </thead> <tbody> <tr> <td></td> <td></td> <td></td> </tr> </tbody> </table>	Tens (10s)	Ones (1s)	Tenths (0.1s)				
Tens (10s)	Ones (1s)	Tenths (0.1s)						
⑦	$20 + 1 + 0.6 = 21.6$		<input type="checkbox"/> Done !					
	<table border="1"> <thead> <tr> <th>Tens (10s)</th> <th>Ones (1s)</th> <th>Tenths (0.1s)</th> </tr> </thead> <tbody> <tr> <td></td> <td></td> <td></td> </tr> </tbody> </table>	Tens (10s)	Ones (1s)	Tenths (0.1s)				
Tens (10s)	Ones (1s)	Tenths (0.1s)						

The importance ideas for leaning

- Practice drawing large, long, and small tiles effectively, and recognize their relation.
- Correspond such drawings with expanded notation.

Objective

1. Compare numbers while using multiple representations.
2. Explain how to get the answer using representation.

III. Comparison

Have you mastered how to represent numbers?
Next, let's compare their sizes!



The importance ideas for leaning

- Use multiple different representations of numbers such as tiles, numerals, and number line for comparing quantities (decimal numbers).

Extra activity E; Which quantity is bigger using tiles?

Objective

Compare the size of two decimal numbers with tenths places using tiles.

Encourage pupils to pay attention to the quantity represented by tiles (the relationship between quantity and tiles). Firstly, paying attention to long tiles (1s). If numbers of long tiles as the same, pay attention to small tiles (0.1s).

Reason means that the teacher asks the pupils how to get the answer. (To be able to explain using own words.)

Extra

E Which quantity is bigger using tiles?

Date

/ 5 Points

① Which quantity is bigger, A or B? Circle A or B.



Done !

② Which quantity is bigger, A or B? Circle A or B.

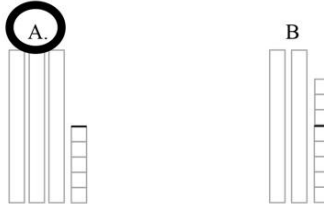

Done !

③ Which quantity is bigger, A or B? Circle A or B.

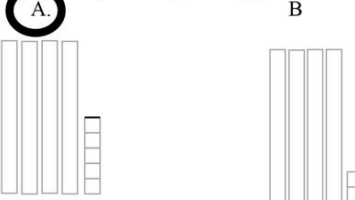

Done !

(Reason)

Which tile did you use to compare, the long tile or the small tile?

Answer [**The small tile**]

⑤ Which quantity is bigger, A or B? Circle A or B.

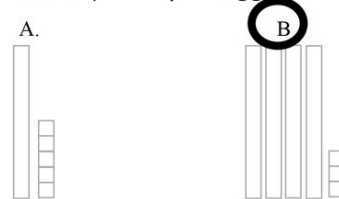

Done !

(Reason)

The importance ideas for leaning

- Compare two quantities, by using long tiles of 1 and small tiles of 0.1 effectively and thinking which tile to pay attention to.

Practice 6; Which quantity is bigger using tiles?

Objective

compare the size of two decimal numbers with tenths places using tiles.

Encourage pupils to pay attention to the quantity represented by tiles (the relationship between quantity and tiles).

Firstly, paying attention to large tiles (10s). If numbers of large tiles as the same, pay attention to long tiles (1s). If numbers of long tiles as the same, pay attention to small tiles (0.1s).

Reason means that the teacher asks the pupils how to get the answer. (To be able to explain using own words.)

Practice

6 Which quantity is bigger using tiles?

Date / 2 Points

①

(1) Which quantity is bigger, A or B? Circle A or B.

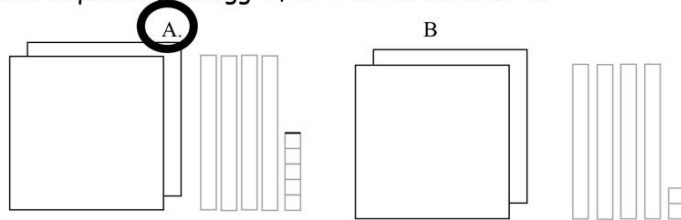

(Reason)

(2) Which tile did you use to compare, **the large tile**, **the long tile**, or **the small tile**?

Answer [**The small tile**]

②

(2) Which quantity is bigger, A or B? Circle A or B.

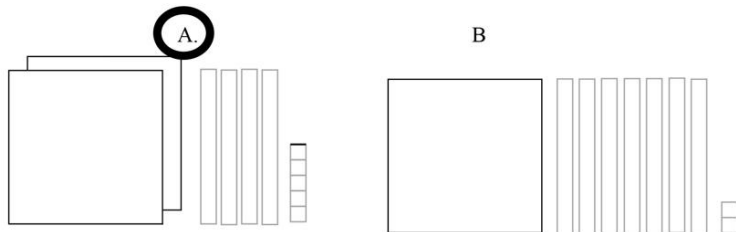

(Reason)

The importance ideas for leaning

- Compare two quantities, by using tiles of 10, 1 and 0.1 effectively and thinking which tile to pay attention to.

Extra activity F; Which quantity is bigger using numerals?

Objective

Compare the size of two decimal numbers with tenths places using numerals.

Encourage pupils to pay attention to the ones and tenths places for comparing.

Reason means that the teacher asks the pupils how to get the answer. (To be able to explain using own words.)

Teach them how to explain which quantities are bigger (more) or smaller (fewer) by paying attention to each place.

Extra

F Which quantity is bigger using numerals?

Date

/ 6 Points

① Which quantity is bigger, 2.4 or 2.9?

(Reason)

	Ones (1s)	Tenths (0.1s)
2.4	2	. 4
2.9	2	. 9

Which place value did you compare, **Ones** or **Tenths**?

Answer [**Tenths**]

Which quantity is bigger, **2.4** or **2.9**?

Answer [**2.9**]

Done !

② Which quantity is bigger, 7.3 or 4.8?

(Reason)

	Ones (1s)	Tenths (0.1s)
7.3	7	. 3
4.8	4	. 8

Which place value did you compare, **Ones** or **Tenths**?

Answer [**Ones**]

Which quantity is bigger, **7.3** or **4.8**?

Answer [**7.3**]

Done !

③ Which quantity is bigger, 8.4 or 8.6?

(Reason)

Answer [**8.6**]

Done !

④ Which quantity is bigger, 5.9 or 6.5?

(Reason)

Answer [**6.5**]

Done !

The importance ideas for leaning

- Compare two quantities, by thinking which place to pay attention to.
- They should be compared from the larger place value.

Practice 7; Which quantity is bigger using numerals?

Objective

Compare the size of two decimal numbers with tenths places using numerals.

Encourage pupils to pay attention to the place value for comparing.

Reason means that the teacher asks the pupils how to get the answer. (To be able to explain using own words.)

Teach them how to explain which quantities are bigger (more) or smaller (fewer) by paying attention to each place.

Practice

7 Which quantity is bigger using numerals?

Date

/ 12 Points

① Which quantity is bigger, 32.1 or 32.5?

(1)

32.1 has [3] in the tens place, [2] in the ones place, and [1] in the tenths place.

32.5 has [3] in the tens place, [2] in the ones place, and [5] in the tenths place.

	Tens (10s)	Ones (1s)	Tenths (0.1s)
32.1	3	2	1
32.5	3	2	5

(Reason)

(2) Which place value did you compare, Tens, Ones or Tenths?

Answer [Tenth]

(3) Which quantity is bigger, 32.1 or 32.5?

Answer [32.5]

② Which quantity is bigger, 52.1 or 35.9?

(1) What are the number of tens, ones, and tenths in each number?

	Tens (10s)	Ones (1s)	Tenths (0.1s)
52.1	5	2	1
35.9	3	5	9

(Reason)

Answer [52.1]

The importance ideas for leaning

- Compare two quantities, by thinking which place to pay attention to.
- Compare them from the larger place value.

Extra activity G; Which quantity is bigger using a number line?

Objective

Compare the size of two decimal numbers with tenths places using number lines.

Encourage pupils to pay attention to the location of numbers on the numbers line for comparison.

Reason means that the teacher asks the pupils how to get the answer. (To be able to explain using own words.)

Extra

G Which quantity is bigger using a number line?

Date

/ 6 Points

① Which quantity is bigger, 0.2 or 0.6?

Indicate the numbers, 0.2 and 0.6, with arrows.

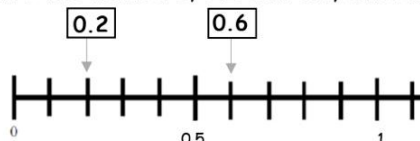

(Reason)

0.6 is to the **[right]** of 0.2, so 0.6 is **[bigger]** than 0.2.

Done !

② Which quantity is bigger, 0.6 or 0.9?

Indicate the numbers, 0.6 and 0.9, with arrows.

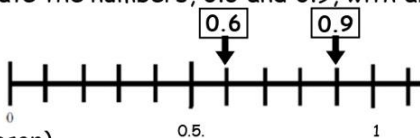

(Reason)

0.9 is to the **[right]** of 0.6, so 0.9 is **[bigger]** than 0.6.

Done !

③ Which quantity is bigger, 1.1 or 0.4?

Indicate the numbers, 1.1 and 0.4, with arrows.

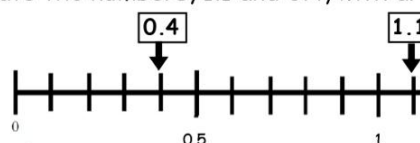

(Reason)

1.1 is to the **[right]** of 0.4, so 1.1 is **[bigger]** than 0.4.

Done !

④ Which quantity is bigger, 1.1 or 0.9?

Indicate the numbers, 1.1 and 0.9, with arrows.

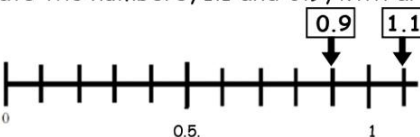

(Reason)

1.1 is to the right of 0.9, so 1.1 is bigger than 0.9.

Done !

The importance ideas for leaning

- Compare two quantities, by thinking of their relative positions (right or left) on the number line.
- Recognize that the number which is on the right is bigger than the number which is on the left on the number line.

Practice 8; Which quantity is bigger using a number line?

Objective

Compare the size of two decimal numbers with tenths places using number lines.

Encourage pupils to pay attention to the location of numbers on the numbers line for comparison.

Reason means that the teacher asks the pupils how to get the answer. (To be able to explain using own words.)

Practice

8 Which quantity is bigger on a number line?

Date

/ 2 Points

① Which quantity is bigger, 3.8 or 3.1?

(1) On the number line, show the numbers, 3.8 and 3.1 with arrows.

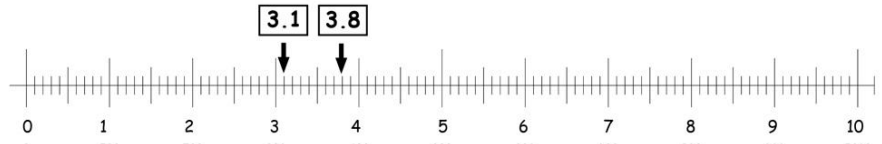

(Reason)

3.8 is to the [right] of 3.1, so 3.8 is [bigger] than 3.1.

(2) Which quantity is bigger?

Answer [3.8]

② Which quantity is bigger, 8.1 or 2.6?

(1) On the number line, show the numbers, 8.1 and 2.6 with arrows.

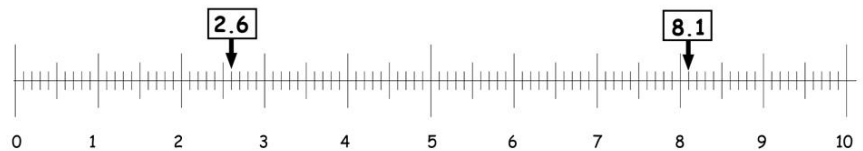

(Reason)

Answer [8.1]

The importance ideas for leaning

- Compare two quantities, by thinking their relative positions (right or left) on the number line.
- Recognize that the number which is on the right is bigger than the number which is on the left on the number line.

Objective

1. Show the meaning of four fundamental operations using representation.
2. Explain how to get the answer using representation.

IV. Calculation

The final part is calculation.
We learn the meaning of four fundamental operations in math.



We have learned to use tiles to represent numbers.
Try to use them during problem solving.

The importance ideas for leaning

- Correlate calculations and representations such as tiles and numerals and explain how they did the calculation.

Extra activity H; How can you do addition?

Objective

Show the meaning of addition using tiles.

Extra

H How can you do addition?

Date

/ 1 Points



What does the calculation symbol (+) represent?

There are 30 eggs. Mr. Mike has brought 12 eggs. How many eggs do you have in total?

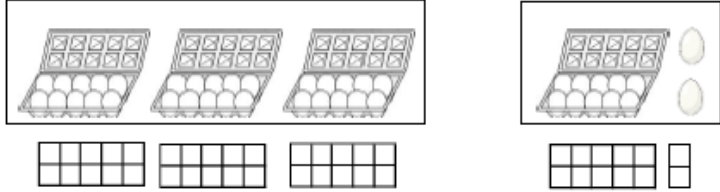

It is represented by the following math sentence.

$$30 + 12 = 42$$

Encourages pupils to understand and explain the meaning of addition through the use of representation.

Show your work means that the teacher asks the pupils how to get the answer.

Encourage the pupils to correspond the numerals and tiles in each place.

① I have 245 tiles.

My friend has 122 tiles.

How many tiles do we have in total?

Show your work.

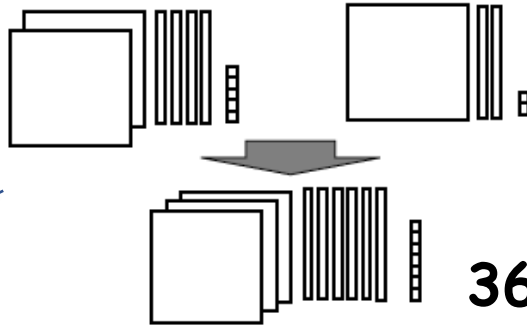

367

Done !

If represents 1,

represents 10

represents 100

The importance ideas for leaning

- Represent two numbers first and then show the meaning of addition using tiles (1s, 10s, and 100s).

Extra activity H'; How can you do addition?

Objective

Show the meaning of addition using tiles.

Encourages pupils to understand and explain the meaning of addition through the use of representation.

Show your work means that the teacher asks the pupils how to get the answer.

Encourage the pupils to correspond the numerals and tiles in each place.

Extra

H' How can you do addition?

Date

/ 1 Points

Mr. Mike had 1.5 meters of chitenge.
He bought another 1.3 meters of chitenge.
How many meters of chitenge did he have?

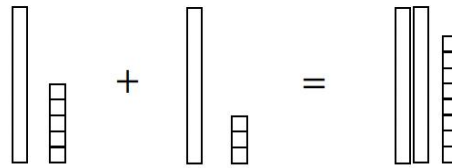
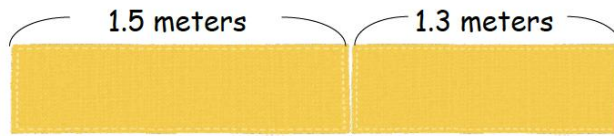

If represents 0.1,

represents 1

represents 10

It is represented by the following math sentence.

$$1.5 + 1.3 = 2.8$$

① I have 2.5 liters of water.
My friend has 3.2 liters of water.
How many liters of water do we have in total?

Done !

Show your work using tiles

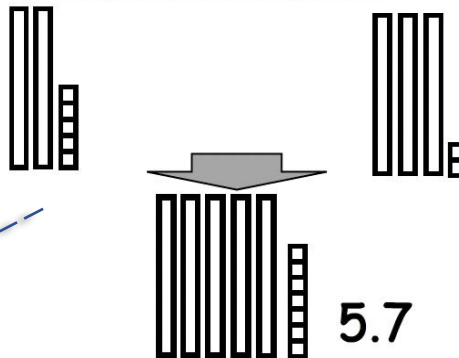

The importance ideas for leaning

- Represent two numbers first and then show the meaning of addition using tiles (1s, and 0.1s).
- When some learners get confused about the representation using tiles, go back to Extra C&D (decimal numbers represented).

Extra activity I; How can you do subtraction?

Objective

Show the meaning of subtraction using tiles.

Encourages pupils to understand and explain the meaning of subtraction through the use of representation.

Show your work means that the teacher asks the pupils how to get the answer.

Encourage the pupils to correspond the numerals and tiles in each place.

Extra

I How can you do subtraction?

Date

/ 1 Points



What does the calculation symbol (-) represent?

There are 20 eggs. Mr. Banda bought 14.
How many eggs are left?

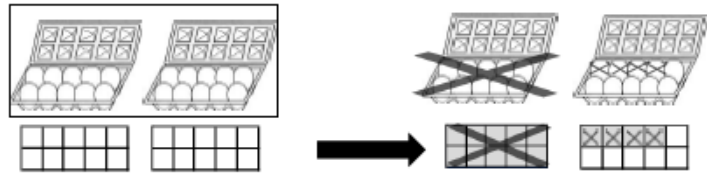

It is represented by the following math sentence.

$$20 - 14 = 6$$

① I have 235 tiles.
I gave 124 tiles to a friend.
How many tiles do I have?

Show your work.

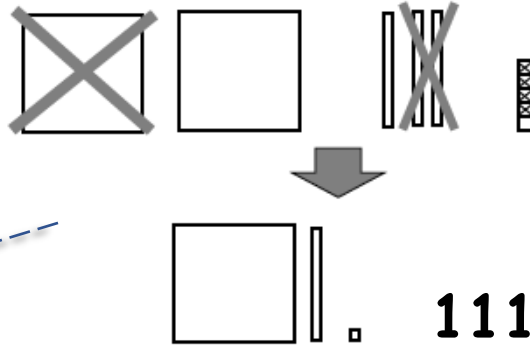

Done !

If represents 1,

represents 10

represents 100

The importance ideas for leaning

- Represent two numbers first and then show the meaning of subtraction using tiles (1s, 10s, and 100s).

Extra activity I'; How can you do subtraction?

Objective

Show the meaning of subtraction using tiles.

Encourages pupils to understand and explain the meaning of subtraction through the use of representation.

Show your work means that the teacher asks the pupils how to get the answer.

Encourage the pupils to correspond the numerals and tiles in each place.

Extra

I' How can you do subtraction?

Date

/ 1 Points

There are 2.8 meters of chitenge.
Ms. Luyando used 1.2 meters of chitenge.
How many meters of chitenge are left?

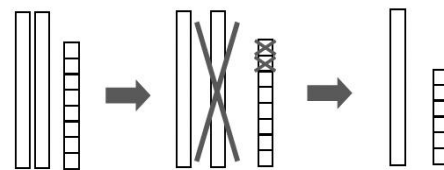
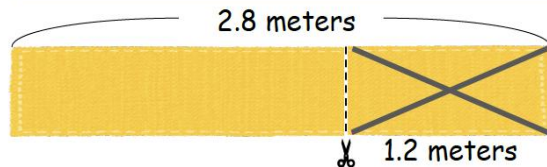

If represents 0.1,
 represents 1
 represents 10

It is represented by the following math sentence.

$$2.8 - 1.2 = 1.6$$

② There are 3.9 liters of water.
I used 1.4 liters of water for cooking.
How many liters of water are left?

Done !

Show your work using tiles

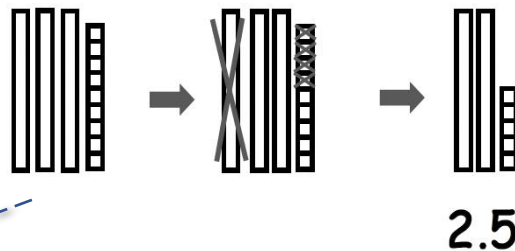

The importance ideas for leaning

- Represent two numbers first and then show the meaning of addition using tiles (1s, and 0.1s).
- When some learners get confused about the representation using tiles, go back to Extra C&D (decimal numbers represented).

Practice 9; Column calculations for addition

Objective

Add numbers in column.

Practice
9

Column calculations for addition.

Date _____ / 8 Points

① $4.2 + 2.1 = 6.3$

$$\begin{array}{r} 4.2 \\ + 2.1 \\ \hline 6.3 \end{array}$$

💡 Calculate from right.

② $0.4 + 0.5 = 0.9$

$$\begin{array}{r} 0.4 \\ + 0.5 \\ \hline 0.9 \end{array}$$

③ $32.1 + 14.2 = 46.3$

$$\begin{array}{r} 32.1 \\ + 14.2 \\ \hline 46.3 \end{array}$$

④ $22.2 + 1.4 = 23.6$

$$\begin{array}{r} 22.2 \\ + 1.4 \\ \hline 23.6 \end{array}$$

⑤ $34.8 + 21.3 = 56.1$

$$\begin{array}{r} 34.8 \\ + 21.3 \\ \hline 56.1 \end{array}$$

💡 Calculate from right.

⑥ $12.9 + 31.4 = 44.3$

$$\begin{array}{r} 12.9 \\ + 31.4 \\ \hline 44.3 \end{array}$$

⑦ $27.4 + 14.3 = 41.7$

$$\begin{array}{r} 27.4 \\ + 14.3 \\ \hline 41.7 \end{array}$$

⑧ $17.8 + 12.2 = 30$

$$\begin{array}{r} 17.8 \\ + 12.2 \\ \hline 30.0 \end{array}$$

📄 Encourage pupils to do calculations from the tenths place (right side).

📄 ⑤ ⑥ ⑦ have with carrying once.
⑧ has with carrying twice.

📄 Teach the pupils to align the numbers neatly by place value and check decimal points. We usually don't write ".0" when tenths place is 0.

The importance ideas for leaning

- Show how to do addition with and without carrying in column form.
- It is very important to align the numbers neatly by place value when writing the numbers in column.
- Check whether the decimal points are aligned.

Practice 10; Column calculations for subtraction

Objective

Subtract numbers in column.

Encourage pupils to do calculations from the tenths place (right side).

⑤ ⑥ ⑦ ⑧ have with borrowing.

Teach the pupils to align the numbers neatly by place value and check decimal points.

Practice

10 Column calculations for subtraction

Date

/ 8 Points

① $6.3 - 4.2 = 2.1$

$$\begin{array}{r} 6.3 \\ - 4.2 \\ \hline 2.1 \end{array}$$

Calculate from right.

② $0.9 - 0.3 = 0.6$

$$\begin{array}{r} 0.9 \\ - 0.3 \\ \hline 0.6 \end{array}$$

③ $36.2 - 12.1 = 24.1$

$$\begin{array}{r} 36.2 \\ - 12.1 \\ \hline 24.1 \end{array}$$

④ $44.4 - 11.2 = 33.2$

$$\begin{array}{r} 44.4 \\ - 11.2 \\ \hline 33.2 \end{array}$$

⑤ $56.1 - 34.8 = 21.3$

$$\begin{array}{r} \overset{5}{\cancel{5}} \overset{10}{\cancel{6}}.1 \\ - 34.8 \\ \hline 21.3 \end{array}$$

Calculate from right.

⑥ $67.1 - 12.5 = 54.6$

$$\begin{array}{r} \overset{6}{\cancel{6}} \overset{10}{\cancel{7}}.1 \\ - 12.5 \\ \hline 54.6 \end{array}$$

⑦ $32.8 - 14.6 = 18.2$

$$\begin{array}{r} \overset{2}{\cancel{3}} \overset{10}{\cancel{2}}.8 \\ - 14.6 \\ \hline 18.2 \end{array}$$

⑧ $20.6 - 12.3 = 8.3$

$$\begin{array}{r} \overset{1}{\cancel{2}} \overset{10}{\cancel{0}}.6 \\ - 12.3 \\ \hline 8.3 \end{array}$$

The importance ideas for leaning

- Show how to do subtraction with and without borrowing in column form.
- It is very important to align the numbers neatly by place value when writing the numbers in column.
- Check whether the decimal points are aligned.

Extra activity J; How can you do multiplication?

Objective

Show the meaning of multiplication using tiles and correspond with it multiplication sentence.

Encourages pupils to understand and explain the meaning of multiplication through the use of representation.

Show your work means that the teacher asks the pupils how to get the answer.

Encourage the pupils to represent multiplicand and multiplier by tiles and find an answer by corresponding tiles and numerals in each place.

Extra
J

How can you do multiplication?

Date

/ 1 Points



What does the calculation symbol (x) represent?

There are 3 bananas on each plate; since there are 5 plates, there are 15 bananas.
How many bananas do you have?



It is represented by the following math sentence.

$$3 + 3 + 3 + 3 + 3 = 15$$

5 groups of 3 bananas

$$5 \times 3 = 15$$

Number of groups

Number in one group.

Total Number

① There are 3 groups of 120 tiles.
How much is it in total?

Done !

multiplier

Show your work



multiplicand

If represents 1.

represents 10

represents 100

$$3 \times 120 = 360$$

360

The importance ideas for leaning

- Represent the quantity (multiplicand) first using tiles (10s, and 100s), and then repeat it number of times (multiplier).
- (multiplier) x (multiplicand) = (product)

Extra activity J'; How can you do multiplication?

Objective

Show the meaning of multiplication using tiles and correspond it with multiplication sentence.

Encourages pupils to understand and explain the meaning of multiplication through the use of representation.

Show your work means that the teacher asks the pupils how to get the answer.

Encourage the pupils to represent multiplicand and multiplier by tiles and find an answer by corresponding tiles and numerals in each place.

Extra

J' How can you do multiplication?

Date

/ 1 Points

A bottle of cooking oil contains 1.2 liters.
Ms.Jane bought 3 bottles of cooking oil.
How many liters of cooking oil does she have altogether?

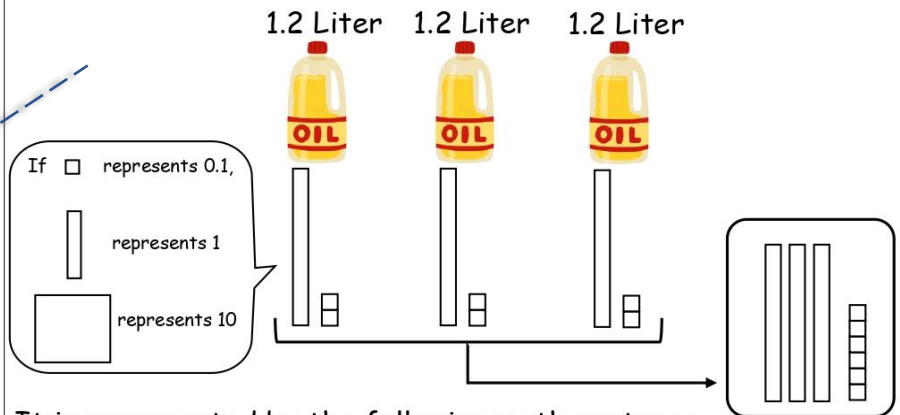

It is represented by the following math sentence.

$$3 \times 1.2 = 3.6$$

① There are 4 packets of sugar.
Each packet has 2.1 kilograms of sugar.
How many kilograms of sugar are there in total?

Done !

Show your work using tiles

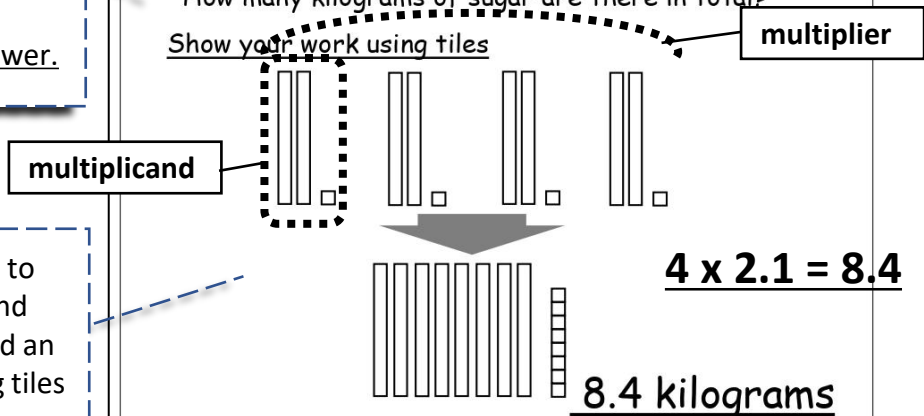

The importance ideas for leaning

- Represent the quantity (multiplicand) first using tiles (1s, and 0.1s), and then repeat it number of times (multiplier).
- (multiplier) x (multiplicand) = (product)
- When some learners get confused about the representation using tiles, go back to Extra C&D (decimal numbers represented).

Practice 11; How can you do multiplication?

Objective

Express the meaning of multiplication as repeated addition.

 Ask pupils what are multiplier and multiplicand in each.

 Multiplier (number of the group) comes first, multiplicand (number in the group) comes later in multiplication sentence.

Practice

11 How can you do multiplication?

Date

/ 4 Points

How do you show a math sentence using addition instead of the following multiplication?

① $4 \times 2.1 = 2.1 + 2.1 + 2.1 + 2.1$

② $3 \times 3.2 = 3.2 + 3.2 + 3.2$

How do you show a math sentence using multiplication instead of the following addition?

③ $3.1 + 3.1 + 3.1 = 3 \times 3.1$

④ $1.3 + 1.3 + 1.3 + 1.3 = 4 \times 1.3$

The importance ideas for leaning

- Represent an operation of multiplication using repeated addition or vice versa.

Extra activity K; How can you do division?

Objective

Show the meaning of division using tiles and correspond it with division sentence.

Encourages pupils to understand and explain the meaning of division through the use of representation.

Show your work means that the teacher asks the pupils how to get the answer.

Encourage the pupils to represent dividend and divisor by tiles and find an answer by corresponding tiles and numerals in each place.

Extra K How can you do division?

Date / 1 Points



What does the calculation symbols (\div) represent?

There are 20 bananas. We share among 5 people. How many bananas does one person have?

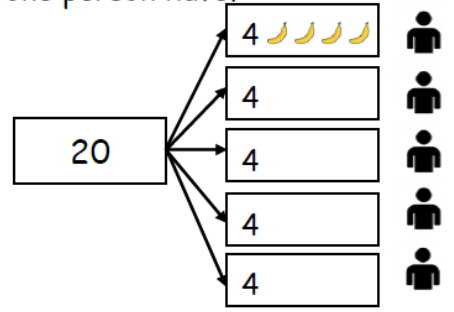
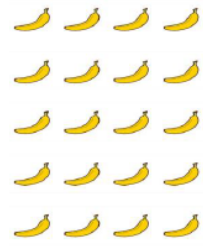

It is represented by the following math sentence.

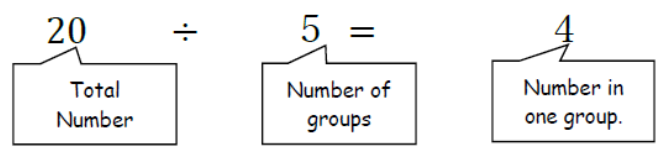

① There are 480 tiles. If we share them among 4 people, how many tiles will one person have?

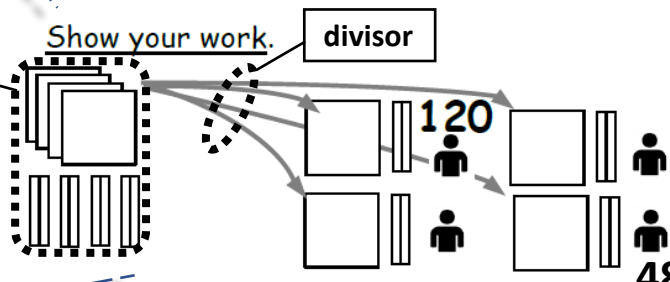

Done !
If represents 1,
 represents 10,
 represents 100

$480 \div 4 = 120$

The importance ideas for leaning

- Represent the quantity (dividend) first, using tiles (10s, and 100s), and then share equally into number of groups (divisor).
- (dividend) \div (divisor) = (quotient)

Extra activity K'; How can you do division?

Objective

Show the meaning of division using tiles and correspond it with division sentence.

Extra
K'

How can you do division?

Date

/ 1 Points

There are 4.8 liters of cooking oil in one bottle.

We share it among 4 people. How many liters of cooking oil does each person have?



Show your work

See the ideas on the next page.

 **Show your work** means that the teacher asks the pupils how to get the answer. For example, **see the ideas on the next page** or **column calculation**.

Continue of the next page →

Continuation of the previous page

There are 4.8 liters of cooking oil in one bottle.
We share it among 4 people. How many liters of cooking oil does each person have?

Arthur's idea



If represents 0.1 liters, represents 1 liter
and represents 10 liters of cooking oil

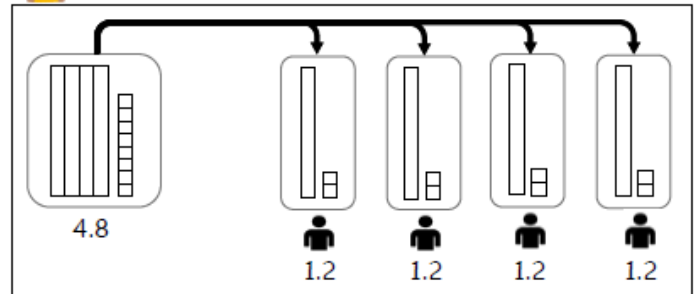

Mutinta's idea

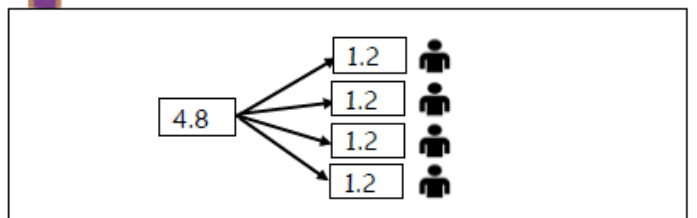

Total amount

Number of people

Amount per person

(Total amount of oil) ÷ (Number of people to share) = (Amount of oil per person)

4.8

÷

4

=

1.2

Answer: **1.2** liters

Respect diverse ideas.

There are ways to get answers such as the usage of tiles and thinking from daily life experiences.

The meaning of division is explained in words.

The teacher may read it with pupils to understand the meaning.

The importance ideas for leaning

- Represent the quantity (dividend) first, using tiles (1s, and 0.1s), and then share equally into number of groups (divisor).
- (dividend) ÷ (divisor) = (quotient)

Practice 12; How can you do division?

Objective

Divide numbers horizontally.

Ask pupils what are dividend and divisor in each.

Show your work means that the teacher asks the pupils how to get the answer. For example, the teacher might encourage the pupils to use the ideas from Arthur and Mutinta that they learned in the previous lesson.

Practice

12 How can you do division?

Date

/ 3 Points

Do the following division.

① $2.4 \div 2 = 1.2$

Show your work.

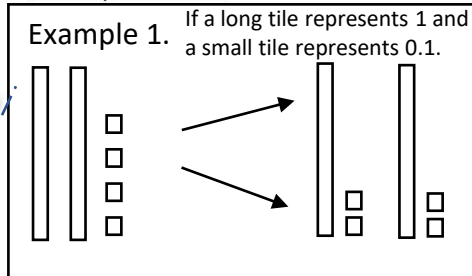

Example 2.

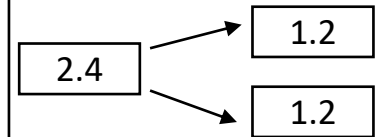

② $3.6 \div 3 = 1.2$

Show your work.

③ $8.4 \div 4 = 2.1$

Show your work.

The importance ideas for leaning

- Represent an operation of division using tiles and/or expanded notation.

Practice 13; Column calculations for multiplication

Objective

Multiply numbers in columns.

Encourage pupils to do calculations from the tenths place (right side).

Encourage the pupils to do multiplication in each place.

Teach the pupils to align the numbers neatly by place value and check decimal points.

Practice

13 Column calculations for multiplication.

Date

/ 8 Points

① $1.2 \times 3 = 3.6$

$$\begin{array}{r} 1.2 \\ \times 3 \\ \hline 3.6 \end{array}$$

Calculate from right.

② $2.1 \times 4 = 8.4$

$$\begin{array}{r} 2.1 \\ \times 4 \\ \hline 8.4 \end{array}$$

③ $0.2 \times 4 = 0.8$

$$\begin{array}{r} 0.2 \\ \times 4 \\ \hline 0.8 \end{array}$$

Calculate from right.

④ $0.3 \times 2 = 0.6$

$$\begin{array}{r} 0.3 \\ \times 2 \\ \hline 0.6 \end{array}$$

⑤ $3.1 \times 4 = 12.4$

$$\begin{array}{r} 3.1 \\ \times 4 \\ \hline 12.4 \end{array}$$

⑥ $6.2 \times 2 = 12.4$

$$\begin{array}{r} 6.2 \\ \times 2 \\ \hline 12.4 \end{array}$$

⑦ $2.5 \times 3 = 7.5$

$$\begin{array}{r} 2.5 \\ \times 3 \\ \hline 1.5 \\ + 6 \\ \hline 7.5 \end{array}$$

2 + 0.5

0.5 × 3

2 × 3

⑧ $1.3 \times 4 = 5.2$

$$\begin{array}{r} 1.3 \\ \times 4 \\ \hline 1.2 \\ 4 \\ \hline 5.2 \end{array}$$

The importance ideas for leaning

- Show how to do multiplication with and without carrying numbers in column form.
- It is very important to align the numbers neatly by place value when writing the numbers in the column.

Practice 14; Column calculations for division

Objective

Divide numbers in column.

Encourage pupils to do calculations from the tens or ones place (left side).

Encourage the pupils to do division in each place.

Teach the pupils to align the numbers neatly by place value and check decimal points.

Practice

14 Column calculation for division.

Date

/ 8 Points

① $3.6 \div 3 = 1.2$

Calculate from left.

$$\begin{array}{r} 1.2 \\ 3 \overline{) 3.6} \\ \underline{3} \\ 0 6 \\ 0 6 \\ \underline{0} 0 \end{array}$$

② $2.8 \div 2 = 1.4$

$$\begin{array}{r} 1.4 \\ 2 \overline{) 2.8} \\ \underline{2} \\ 0 8 \\ 0 8 \\ \underline{0} 0 \end{array}$$

③ $0.8 \div 4 = 0.2$

$$\begin{array}{r} 0.2 \\ 4 \overline{) 0.8} \\ \underline{0} 8 \\ 0 8 \\ \underline{0} 0 \end{array}$$

④ $5.7 \div 3 = 1.9$

$$\begin{array}{r} 1.9 \\ 3 \overline{) 5.7} \\ \underline{3} \\ 2 7 \\ 2 7 \\ \underline{0} 0 \end{array}$$

⑤ $48.4 \div 4 = 12.1$

Calculate from left.

$$\begin{array}{r} 12.1 \\ 4 \overline{) 48.4} \\ \underline{4} \\ 0 8 4 \\ 0 8 4 \\ \underline{0} 0 4 \\ 0 4 \\ \underline{0} 0 \end{array}$$

⑥ $33.6 \div 3 = 11.2$

$$\begin{array}{r} 11.2 \\ 3 \overline{) 33.6} \\ \underline{3} \\ 0 3 6 \\ 0 3 6 \\ \underline{0} 0 6 \\ 0 6 \\ \underline{0} 0 \end{array}$$

⑦ $1.8 \div 3 = 0.6$

Calculate from left.

$$\begin{array}{r} 0.6 \\ 3 \overline{) 1.8} \\ \underline{1} 8 \\ 1 8 \\ \underline{0} 0 \end{array}$$

⑧ $3.2 \div 4 = 0.8$

$$\begin{array}{r} 0.8 \\ 4 \overline{) 3.2} \\ \underline{3} 2 \\ 3 2 \\ \underline{0} 0 \end{array}$$

The importance ideas for leaning

- Show how to do division with and without borrowing in column form.
- It is very important to align the numbers neatly by place value when writing the numbers in the column.
- Check whether the decimal points are aligned.

本研究は JSPS 科研費 研究課題/領域番号: 21KK0038 の助成を受けたものです。